

TFT COLOR LCD MODULE

NL2432HC22-40J

**8.9cm (3.5 Type)
QVGA**

DATA SHEET

DOD-PP-0129 (3rd edition)

**This DATA SHEET is updated document from
DATA SHEET DOD-PP-0011(2).**

**All information is subject to change without notice.
Please confirm the sales representative before
starting to design your system.**

INTRODUCTION

The Copyright to this document belongs to NEC LCD Technologies, Ltd. (hereinafter called "NEC"). No part of this document will be used, reproduced or copied without prior written consent of NEC.

NEC does and will not assume any liability for infringement of patents, copyrights or other intellectual property rights of any third party arising out of or in connection with application of the products described herein except for that directly attributable to mechanisms and workmanship thereof. No license, express or implied, is granted under any patent, copyright or other intellectual property right of NEC.

Some electronic parts/components would fail or malfunction at a certain rate. In spite of every effort to enhance reliability of products by NEC, the possibility of failures and malfunction might not be avoided entirely. To prevent the risks of damage to death, human bodily injury or other property arising out thereof or in connection therewith, each customer is required to take sufficient measures in its safety designs and plans including, but not limited to, redundant system, fire-containment and anti-failure.

The products are classified into three quality grades: "**Standard**", "**Special**", and "**Specific**" of the highest grade of a quality assurance program at the choice of a customer. Each quality grade is designed for applications described below. Any customer who intends to use a product for application other than that of Standard quality grade is required to contact an NEC sales representative in advance.

The **Standard** quality grade applies to the products developed, designed and manufactured in accordance with the NEC standard quality assurance program, which are designed for such application as any failure or malfunction of the products (sets) or parts/components incorporated therein a customer uses are, directly or indirectly, free of any damage to death, human bodily injury or other property, like general electronic devices.

Examples: Computers, office automation equipment, communications equipment, test and measurement equipment, audio and visual equipment, home electronic appliances, machine tools, personal electronic equipment, industrial robots, etc.

The **Special** quality grade applies to the products developed, designed and manufactured in accordance with an NEC quality assurance program stricter than the standard one, which are designed for such application as any failure or malfunction of the products (sets) or parts/components incorporated therein a customer uses might directly cause any damage to death, human bodily injury or other property, or such application under more severe condition than that defined in the Standard quality grade without such direct damage.

Examples: Control systems for transportation equipment (automobiles, trains, ships, etc.), traffic control systems, anti-disaster systems, anti-crime systems, medical equipment not specifically designed for life support, safety equipment, etc.

The **Specific** quality grade applies to the products developed, designed and manufactured in accordance with the standards or quality assurance program designated by a customer who requires an extremely higher level of reliability and quality for such products.

Examples: Military systems, aircraft control equipment, aerospace equipment, nuclear reactor control systems, medical equipment/devices/systems for life support, etc.

The quality grade of this product is the "**Standard**" unless otherwise specified in this document.

CONTENTS

INTRODUCTION2

1. OUTLINE.....4

 1.1 STRUCTURE AND PRINCIPLE.....4

 1.2 APPLICATION4

 1.3 FEATURES.....4

2. GENERAL SPECIFICATIONS5

3. BLOCK DIAGRAM.....6

4. DETAILED SPECIFICATIONS8

 4.1 MECHANICAL SPECIFICATIONS.....8

 4.2 ABSOLUTE MAXIMUM RATINGS8

 4.3 ELECTRICAL CHARACTERISTICS.....9

 4.4 SETTING OF THE INTERNAL RESISTER.....10

 4.5 INTERFACE PIN CONNECTIONS13

 4.6 DISPLAY COLORS AND INPUT DATA SIGNALS15

 4.7 DISPLAY POSITIONS.....16

 4.8 SCANNING DIRECTIONS16

 4.9 INPUT SIGNAL TIMINGS.....17

 4.9.1 RGB interface (Ta= 25°C, VCC= 3.0V)17

 4.9.2 Serial interface (Ta= 25°C, VCC= 3.0V).....20

 4.10 OPTICAL CHARACTERISTICS21

5. RELIABILITY TESTS.....24

6. PRECAUTIONS25

 6.1 MEANING OF CAUTION SIGNS25

 6.2 CAUTIONS25

 6.3 ATTENTIONS25

 6.3.1 Handling of the product25

 6.3.2 Environment.....26

 6.3.3 Characteristics.....26

 6.3.4 Other26

7. OUTLINE DRAWINGS27

1. OUTLINE

1.1 STRUCTURE AND PRINCIPLE

Color LCD module NL2432HC22-40J is composed of the amorphous silicon thin film transistor liquid crystal display (a-Si TFT LCD) panel structure with driver LSIs for driving the TFT (Thin Film Transistor) array and a backlight.

The a-Si TFT LCD panel structure is injected liquid crystal material into a narrow gap between the TFT array glass substrate and a color-filter glass substrate.

Color (Red, Green, Blue) data signals from a host system (e.g. signal generator, etc.) are modulated into best form for active matrix system by a controller, and sent to the driver LSIs which drive the individual TFT arrays.

The TFT array as an electro-optical switch regulates the amount of transmitted light from the backlight assembly, when it is controlled by data signals. Color images are created by regulating the amount of transmitted light through the TFT array of red, green and blue dots.

1.2 APPLICATION

- PDAs

1.3 FEATURES

- Adoption of SR-NLT (Super-Reflective Natural Light TFT) (Transflective type)
- Backlight attached
- High luminance
- High contrast
- Including LCD controller and power supply
- 6-bit digital RGB signals

2. GENERAL SPECIFICATIONS

| | |
|-----------------------------------|--|
| <i>Display area</i> | 53.64 (H) × 71.52 (V) mm |
| <i>Diagonal size of display</i> | 8.9cm (3.5 inches) |
| <i>Drive system</i> | a-Si TFT active matrix |
| <i>Display color</i> | 262,144 colors |
| <i>Pixel</i> | 240 (H) × 320 (V) pixels |
| <i>Pixel arrangement</i> | RGB (Red dot, Green dot, Blue dot) vertical stripe |
| <i>Dot pitch</i> | 0.0745 (H) × 0.2235 (V) mm |
| <i>Pixel pitch</i> | 0.2235 (H) × 0.2235 (V) mm |
| <i>Module size</i> | 63.5 (H) × 85.0 (V) × 3.0 (D) mm (typ.) |
| <i>Weight</i> | 25 g (typ.) |
| <i>Polarizer surface</i> | Clear |
| <i>Polarizer pencil-hardness</i> | 3H (min.) [by JIS K5400] |
| <i>Luminance</i> | At $IL = 20mA$ 220cd/m ² (typ.) |
| <i>Reflectance ratio</i> | 15% (typ.) |
| <i>Contrast ratio</i> | At transmissive mode, $IL = 20mA$ 150:1 (typ.) |
| | At reflective mode 15:1 (typ.) |
| <i>Response time</i> | $Ton + Toff$ (10% ← → 90%) 30 ms (typ., at transmissive mode) 16 ms (typ., at reflective mode) |
| <i>Designed viewing direction</i> | Viewing direction without image reversal: down side (6 o'clock) |
| <i>Signal system</i> | 6-bit digital signals for data of RGB colors, Dot clock (CLK), Horizontal synchronous signal (HSYNC), Vertical synchronous signal (VSYNC) Serial interface signals (/CS, SCL, SI) |
| <i>Supply voltage</i> | VCC: 3.0V (typ.) |
| <i>Power consumption</i> | LCD panel: 50mW (typ.) Backlight: 384mW (typ., at $IL = 20mA$) |

3. BLOCK DIAGRAM

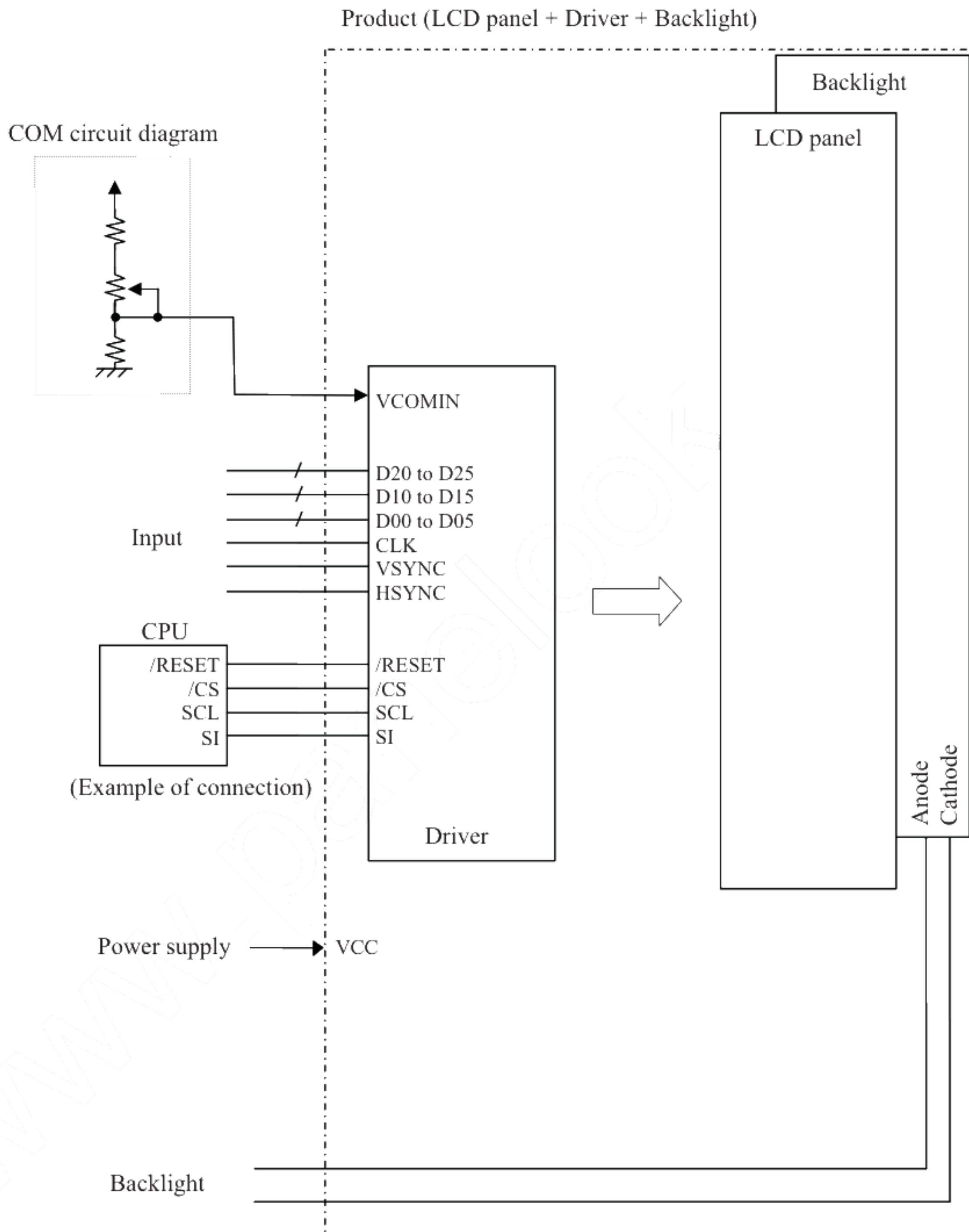

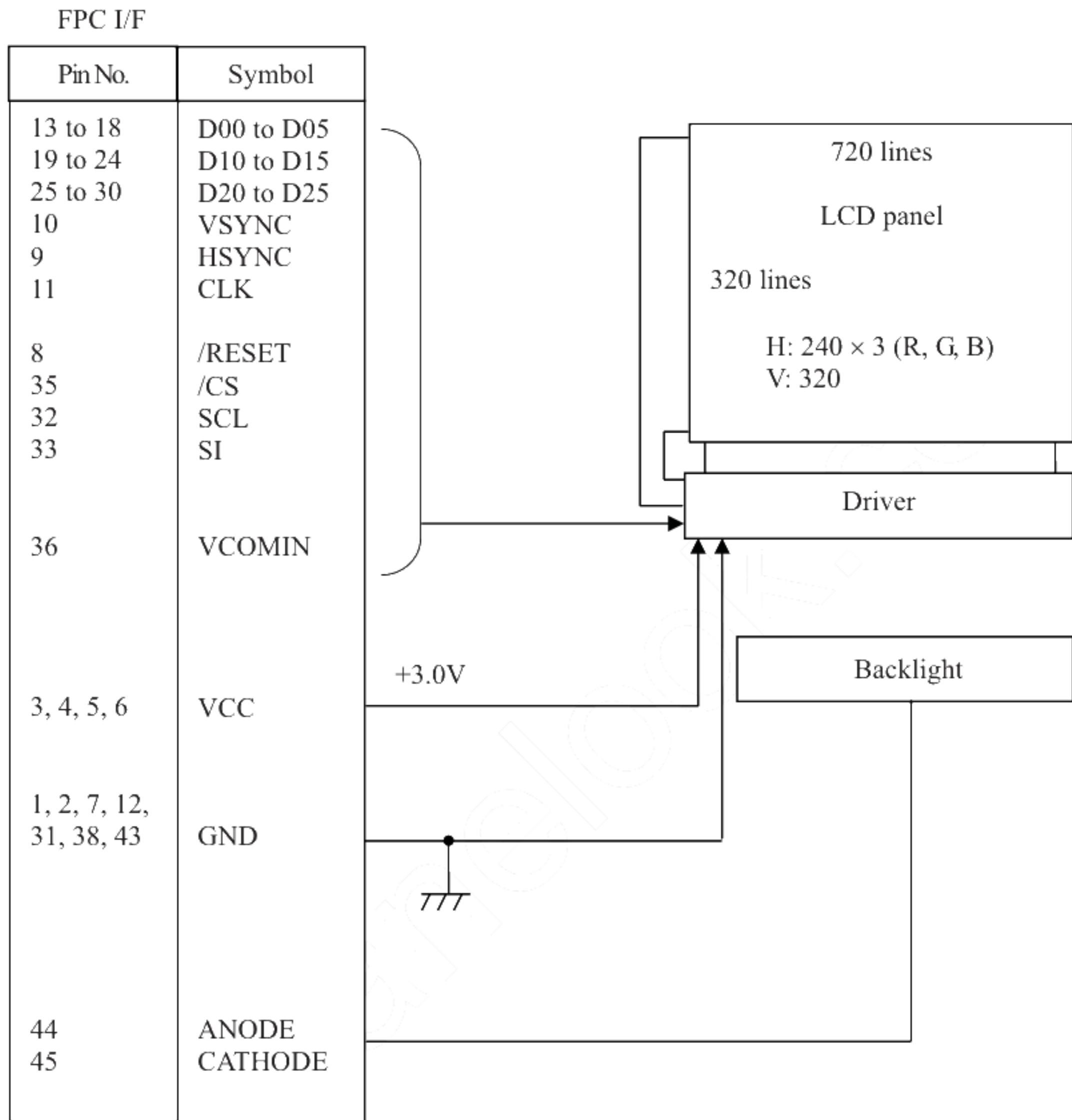

Reference design of COM circuit

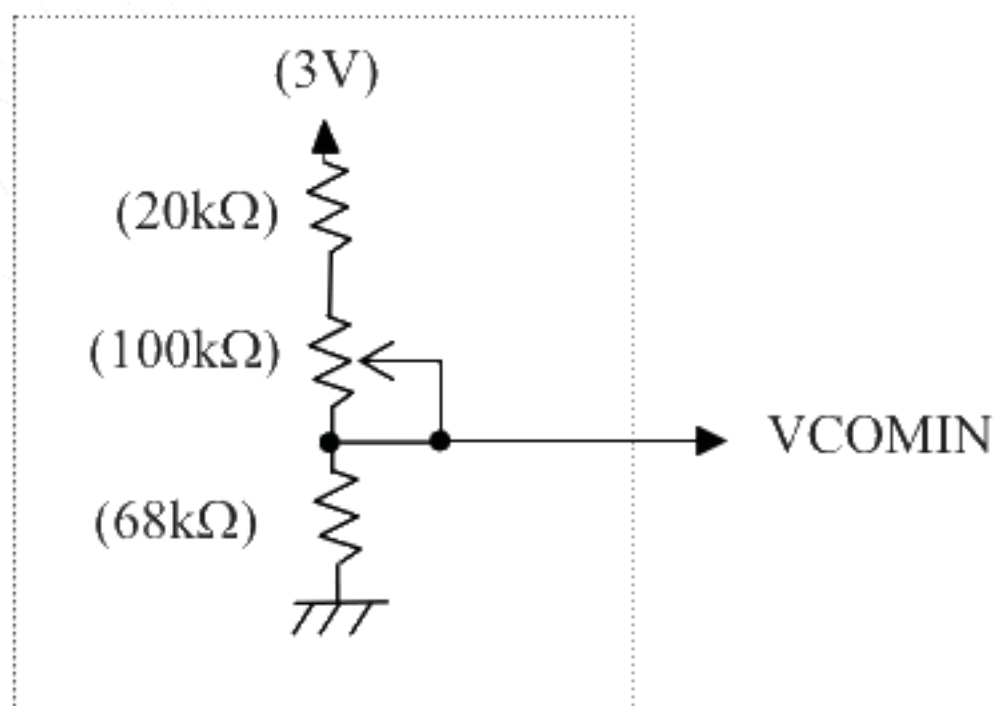

☆

4. DETAILED SPECIFICATIONS

4.1 MECHANICAL SPECIFICATIONS

| Parameter | Specification | Unit |
|--------------|---|------|
| Module size | 63.5 ± 0.3 (W) × 85.0 ± 0.3 (H) × 3.0 ± 0.2 (D) | mm |
| Display area | 53.64 (H) × 71.52 (V) | mm |
| Weight | 25 (typ.), 28 (max.) | g |

Note1: See "7. OUTLINE DRAWINGS".

4.2 ABSOLUTE MAXIMUM RATINGS

| Parameter | Symbol | Rating | Unit | Remarks |
|-----------------------|-----------------------|-----------------|------------------|-----------------------|
| Supply voltage | VCC | -0.5 to +3.5 | V | Ta= 25°C |
| Logic input voltage | VI | -0.5 to VCC+0.5 | V | Logic signals |
| Backlight | Reverse voltage | VR | ≤ 30 | Ta= 25°C |
| | Power dissipation | PD | ≤ 738 | |
| | Forward current | IL | Note1 | |
| | Pulse forward current | IFP | 100 | |
| Storage temperature | Tst | -20 to +70 | °C | - |
| Operating temperature | Top | -20 to +70 | | Product surface Note2 |
| Relative humidity | RH | ≤ 95 | % | Ta ≤ 40°C |
| | | ≤ 85 | | 40°C < Ta ≤ 50°C |
| | | ≤ 70 | | 50°C < Ta ≤ 55°C |
| Absolute humidity | AH | ≤ 73 Note4 | g/m ³ | Ta > 55°C |
| Storage altitude | | ≤ 13,600 | m | -20°C ≤ Ta ≤ 70°C |
| Operating altitude | | ≤ 4,850 | m | -20°C ≤ Ta ≤ 70°C |

Note1: Allowable forward current

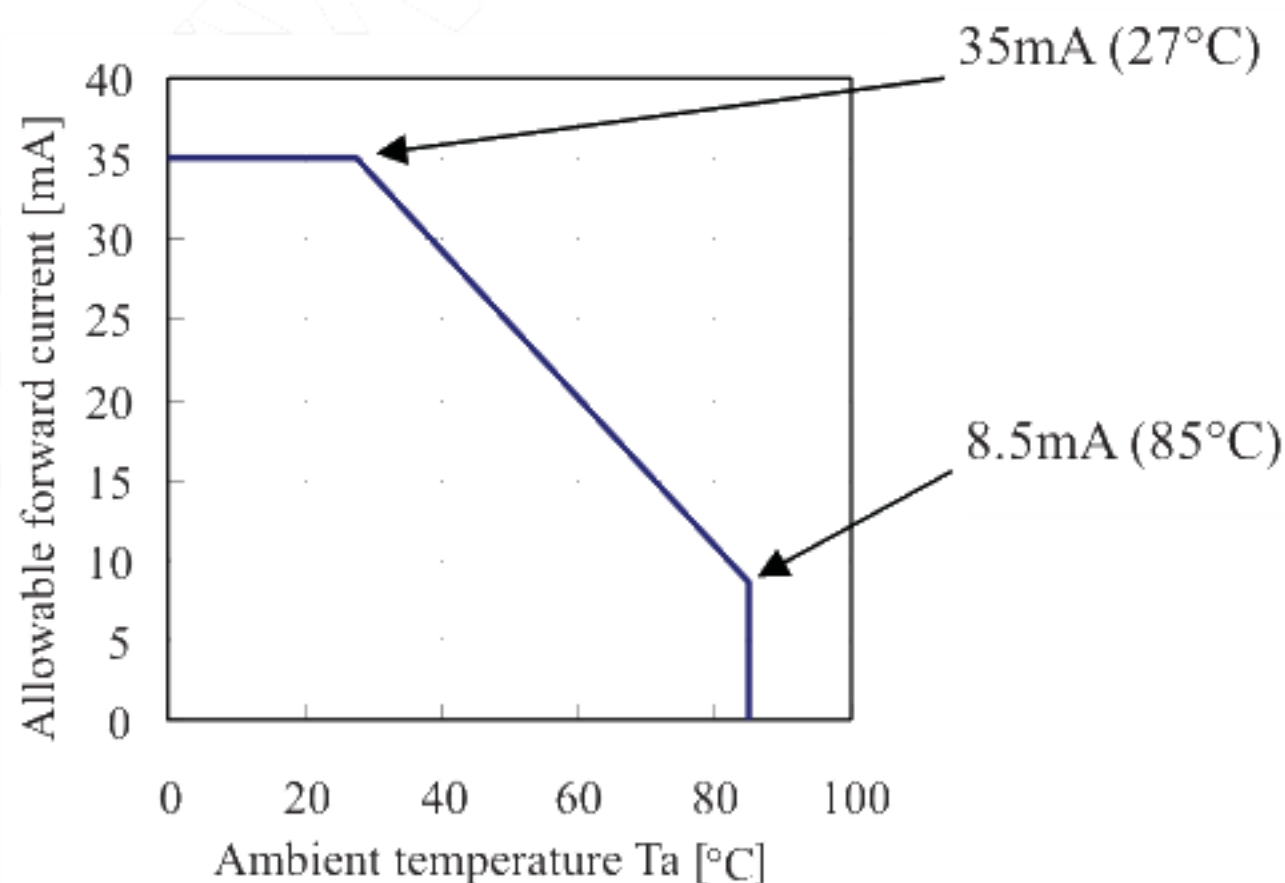

Note2: Measured at display area

Note3: No condensation

Note4: Water amount at Ta= 55°C and RH= 70%

4.3 ELECTRICAL CHARACTERISTICS

(1) Logic/ LCD driving

(Ta= 25°C)

| Parameter | Symbol | min. | typ. | max. | Unit | Remarks |
|--------------------------|--------|--------|------|--------|------|--------------------|
| Logic supply voltage | VCC | 2.85 | 3.0 | 3.15 | V | - |
| Logic input high voltage | VIH | 0.8VCC | - | VCC | V | Logic signal |
| Logic input low voltage | VIL | 0 | - | 0.2VCC | V | |
| COM high voltage | COM/H | - | 1.8 | - | V | at VCC= 3.0V Note1 |
| VCC supply current | ICC | - | 16.5 | 26 | mA | at VCC= 3.0V Note2 |

Note1: The optimum value for COM/H is in the range of 1.3 V to 2.3 V.

Recommended adjustment display for COM/H



Note2: PPCLK= (5.0)MHz, PPHSYNC= (19.53)kHz, PPVSYNC= (60)Hz,
 Checkered flag pattern (by EIAJ ED-2522)

(2) Backlight

(Ta= 25°C)

| Parameter | Symbol | min. | typ. | max. | Unit | Remarks |
|-----------------|--------|------|------|------|------|-------------|
| Forward Current | IL | - | 20 | 22 | mA | - |
| Forward Voltage | VL | - | 19.2 | 21.0 | V | at IL= 20mA |

4.4 SETTING OF THE INTERNAL RESISTER

Initial setting of the internal Resister is undefined data. So the Resister Data must be written in the Resister, after initialization by the /RESET pin. The Resister Data can be written from serial interface pins (/CS, SCL and SI). The setting method is as follows.

(1) Command Byte Function

| Bits | Functions | Discription |
|------|------------------------|-----------------------------------|
| A7 | - | - |
| A6 | - | - |
| A5 | Read / Write | 0:Write 1:Read |
| A4 | - | - |
| A3 | - | - |
| A2 | - | - |
| A1 | - | - |
| A0 | Register Number / Data | 0:Register Number 1:Register Data |

(2) Timing chart

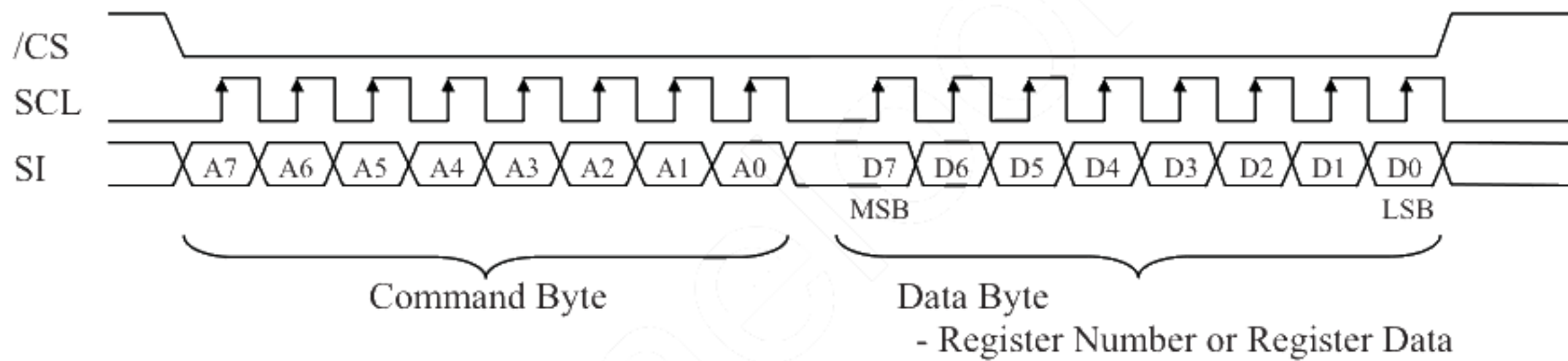

Ex) When data 55h is written to Register R26 (R1Ah)

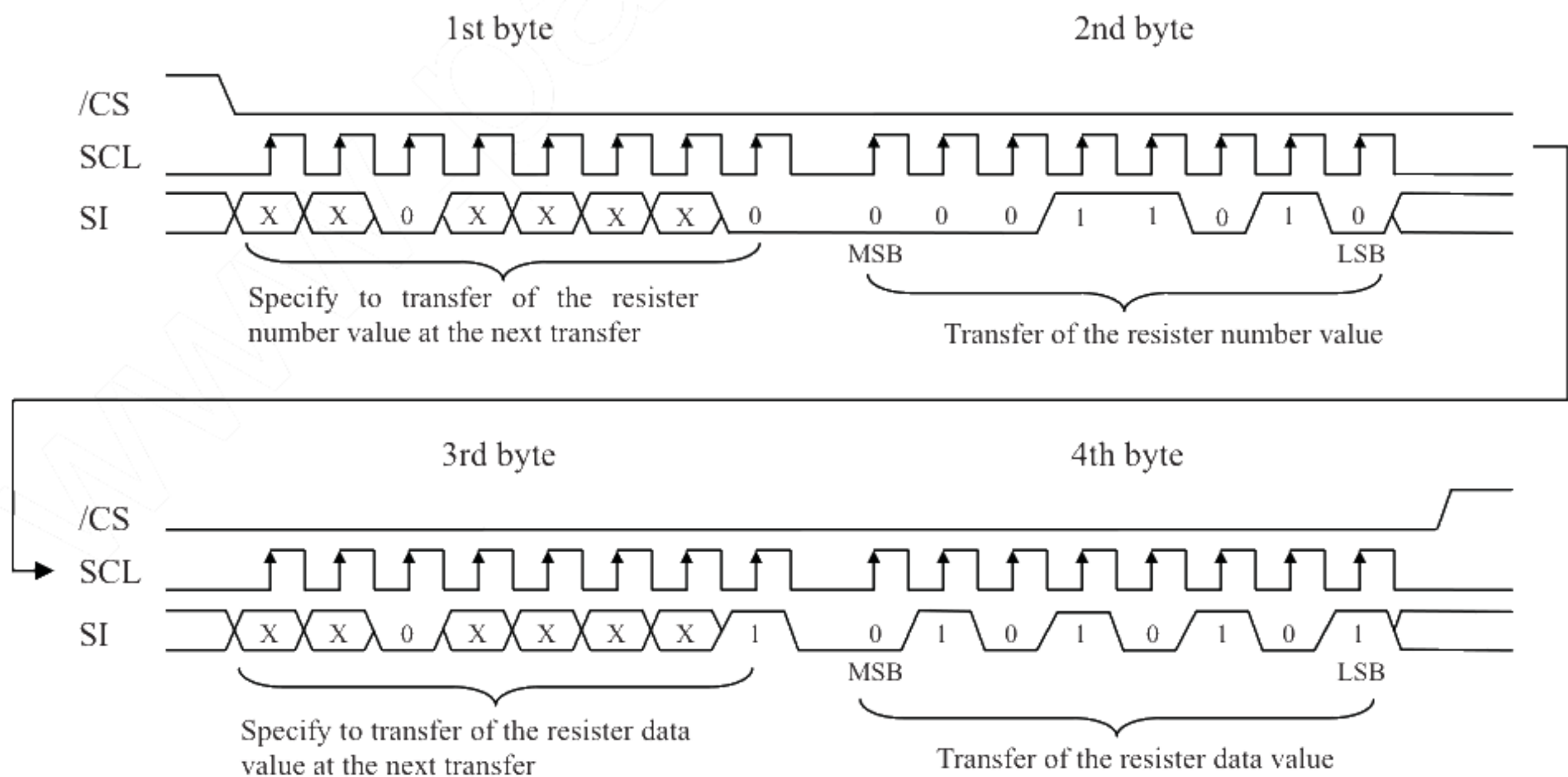

Note1: During 32-bit transfer of the Resister Data, /CS pin (Pin No.35) must be maintained active.

Note2: "X" is set in accordance with the usage conditions.

(3) Command sequence

①Power On

| Sequence | Register Number | Data | Comment | Sequence | Register Number | Data | Comment |
|----------|--------------------------------------|------|---------|----------|------------------|------|---------|
| 1 | Power On | | | 26 | R76 | 01h | - |
| 2 | 1ms min. wait. | | | 27 | R77 | 01h | - |
| 3 | Reset by the /RESET pin (Pin No. 8). | | | 28 | R80 | 00h | - |
| 4 | 1ms min. wait after /RESET↑. | | | 29 | R81 | 00h | - |
| 5 | R3 | 01h | - | 30 | R82 | 2Eh | - |
| 6 | R1 | 00h | - | 31 | R83 | C4h | - |
| 7 | R100 | 0Fh | - | 32 | R86 | 15h | - |
| 8 | R101 | 3Fh | - | 33 | R87 | EDh | - |
| 9 | R102 | 3Fh | - | 34 | R95 | 3Fh | - |
| 10 | R103 | 00h | - | 35 | R96 | 22h | - |
| 11 | R104 | 00h | - | 36 | R25 | 76h | - |
| 12 | R105 | 30h | - | 37 | R26 | 54h | - |
| 13 | R106 | 04h | - | 38 | R27 | 67h | - |
| 14 | R107 | 37h | - | 39 | R28 | 60h | - |
| 15 | R108 | 17h | - | 40 | R29 | 04h | - |
| 16 | R109 | 00h | - | 41 | R30 | 1Ch | - |
| 17 | R110 | 40h | - | 42 | R31 | A9h | - |
| 18 | R111 | 30h | - | 43 | R32 | 00h | - |
| 19 | R112 | 04h | - | 44 | R33 | 20h | - |
| 20 | R113 | 37h | - | 45 | R24 | 77h | - |
| 21 | R114 | 17h | - | 46 | 30 μs min. wait. | | |
| 22 | R115 | 00h | - | 47 | Data input start | | |
| 23 | R116 | 40h | - | 48 | R59 | 01h | - |
| 24 | R2 | 40h | - | 49 | 20 ms min. wait. | | |
| 25 | R75 | 04h | - | 50 | R0 | 00h | 49 |

②Power Off

| Sequence | Register Number | Data | Comment |
|----------|------------------|------|---------|
| 1 | R0 | 08h | - |
| 2 | 25 ms min. wait. | | |
| 3 | R24 | 00h | - |
| 4 | 20 ms min. wait. | | |
| 5 | R1 | 08h | - |
| 6 | Power Off | | |

③ Standby

| Sequence | Register Number | Data | Comment |
|----------|------------------|------|---------|
| 1 | R0 | 08h | - |
| 2 | 25 ms min. wait. | | |
| 3 | R24 | 00h | - |
| 4 | 20 ms min. wait. | | |
| 5 | R1 | 08h | - |

④ Wake Up

| Sequence | Register Number | Data | Comment |
|----------|-----------------------|------|---------|
| 1 | R1 | 00h | - |
| 2 | R24 | FFh | - |
| 3 | 30 μ s min. wait. | | |
| 4 | R0 | 00h | - |

Note1: Be sure to perform reset by the /RESET pin (Pin No. 8) every power-on

Note2: Write the Register Data every power-on, because the data are not stored in the product.

4.5 INTERFACE PIN CONNECTIONS

CN1 (FPC)

Adaptable socket: FH23-45S-0.3SHW(05) (Hirose Electric Co., Ltd.(HRS))

| Pin No. | Symbols | Functions | Pin No. | Symbols | Functions |
|---------|---------|-------------------------------|---------|---------|------------------------|
| 1 | GND | Ground Note1 | 25 | D20 | Red data (LSB) |
| 2 | GND | Ground Note1 | 26 | D21 | Red data |
| 3 | VCC | Power supply Note1 | 27 | D22 | Red data |
| 4 | VCC | | 28 | D23 | Red data |
| 5 | VCC | | 29 | D24 | Red data |
| 6 | VCC | | 30 | D25 | Red data (MSB) |
| 7 | GND | Ground Note1 | 31 | GND | Ground Note1 |
| 8 | /RESET | Reset | 32 | SCL | Serial clock |
| 9 | HSYNC | Horizontal synchronous signal | 33 | SI | Serial input |
| 10 | VSYNC | Vertical synchronous signal | 34 | RSVD | Keep this pin Open. |
| 11 | CLK | Dot clock | 35 | /CS | Chip selection |
| 12 | GND | Ground Note1 | 36 | VCOMIN | COM high voltage input |
| 13 | D00 | Blue data (LSB) | 37 | N.C. | Keep this pin Open. |
| 14 | D01 | Blue data | 38 | GND | Ground Note1 |
| 15 | D02 | Blue data | 39 | N.C. | Keep this pin Open. |
| 16 | D03 | Blue data | 40 | N.C. | |
| 17 | D04 | Blue data | 41 | N.C. | |
| 18 | D05 | Blue data (MSB) | 42 | N.C. | |
| 19 | D10 | Green data (LSB) | 43 | GND | Ground Note1 |
| 20 | D11 | Green data | 44 | ANODE | LED voltage (Anode) |
| 21 | D12 | Green data | 45 | CATHODE | LED voltage (Cathode) |
| 22 | D13 | Green data | | | |
| 23 | D14 | Green data | | | |
| 24 | D15 | Green data (MSB) | | | |

Note1: All GND terminals should be used without any non-connected lines.

Note2: Do not fold the FPC. When folding the FPC, pattern disconnection may occur. In case of bending FPC, the minimum curvature (R) must be more than 1.0 mm.

Description of terminals

| Terminals | Description |
|-------------------|--|
| /RESET | When /RESET is L, an internal reset is performed. The reset operation is executed at the /RESET signal level. Be sure to perform reset by this pin every power-on. |
| /CS | This pin is used for chip selection signals. When /CS= L, the chip is active and can perform data I/O operations including command and data I/O. |
| SCL | This pin is clock input of serial interface. |
| SI | This pin is data input of serial interface. |
| VCOMIN | This pin is the Common high voltage. The voltage needs to be adjusted. See "3 BLOCK DIAGRAM - Reference design of COM circuit". |
| ANODE, CATHODE | Refer to the below "Circuits of backlight". |

Note1: Circuits of backlight



Circuits of backlight

4.6 DISPLAY COLORS AND INPUT DATA SIGNALS

This product can display in equivalent to 262,144 colors in 64 gray scales. Also the relation between display colors and input data signals is as the following table.

| Display colors | | Data signal (0: Low level, 1: High level) | | | | | | | | | | | | | | | | | |
|------------------|---------|---|----|----|----|----|----|----|----|----|----|----|----|----|----|----|----|----|----|
| | | R5 | R4 | R3 | R2 | R1 | R0 | G5 | G4 | G3 | G2 | G1 | G0 | B5 | B4 | B3 | B2 | B1 | B0 |
| Basic colors | Black | 0 | 0 | 0 | 0 | 0 | 0 | 0 | 0 | 0 | 0 | 0 | 0 | 0 | 0 | 0 | 0 | 0 | 0 |
| | Blue | 0 | 0 | 0 | 0 | 0 | 0 | 0 | 0 | 0 | 0 | 0 | 0 | 1 | 1 | 1 | 1 | 1 | 1 |
| | Red | 1 | 1 | 1 | 1 | 1 | 1 | 0 | 0 | 0 | 0 | 0 | 0 | 0 | 0 | 0 | 0 | 0 | 0 |
| | Magenta | 1 | 1 | 1 | 1 | 1 | 1 | 0 | 0 | 0 | 0 | 0 | 0 | 1 | 1 | 1 | 1 | 1 | 1 |
| | Green | 0 | 0 | 0 | 0 | 0 | 0 | 1 | 1 | 1 | 1 | 1 | 1 | 0 | 0 | 0 | 0 | 0 | 0 |
| | Cyan | 0 | 0 | 0 | 0 | 0 | 0 | 1 | 1 | 1 | 1 | 1 | 1 | 1 | 1 | 1 | 1 | 1 | 1 |
| | Yellow | 1 | 1 | 1 | 1 | 1 | 1 | 1 | 1 | 1 | 1 | 1 | 1 | 0 | 0 | 0 | 0 | 0 | 0 |
| | White | 1 | 1 | 1 | 1 | 1 | 1 | 1 | 1 | 1 | 1 | 1 | 1 | 1 | 1 | 1 | 1 | 1 | 1 |
| Red gray scale | Black | 0 | 0 | 0 | 0 | 0 | 0 | 0 | 0 | 0 | 0 | 0 | 0 | 0 | 0 | 0 | 0 | 0 | 0 |
| | | 0 | 0 | 0 | 0 | 0 | 1 | 0 | 0 | 0 | 0 | 0 | 0 | 0 | 0 | 0 | 0 | 0 | 0 |
| | dark | 0 | 0 | 0 | 0 | 1 | 0 | 0 | 0 | 0 | 0 | 0 | 0 | 0 | 0 | 0 | 0 | 0 | 0 |
| | ↑ | | | | : | | | | | : | | | | | | : | | | |
| | ↓ | | | | : | | | | | : | | | | | | : | | | |
| | bright | 1 | 1 | 1 | 1 | 0 | 1 | 0 | 0 | 0 | 0 | 0 | 0 | 0 | 0 | 0 | 0 | 0 | 0 |
| | 1 | 1 | 1 | 1 | 1 | 0 | 0 | 0 | 0 | 0 | 0 | 0 | 0 | 0 | 0 | 0 | 0 | 0 | |
| Red | 1 | 1 | 1 | 1 | 1 | 1 | 0 | 0 | 0 | 0 | 0 | 0 | 0 | 0 | 0 | 0 | 0 | 0 | |
| Green gray scale | Black | 0 | 0 | 0 | 0 | 0 | 0 | 0 | 0 | 0 | 0 | 0 | 0 | 0 | 0 | 0 | 0 | 0 | 0 |
| | | 0 | 0 | 0 | 0 | 0 | 0 | 0 | 0 | 0 | 0 | 1 | 0 | 0 | 0 | 0 | 0 | 0 | 0 |
| | dark | 0 | 0 | 0 | 0 | 0 | 0 | 0 | 0 | 0 | 1 | 0 | 0 | 0 | 0 | 0 | 0 | 0 | 0 |
| | ↑ | | | | : | | | | | : | | | | | | : | | | |
| | ↓ | | | | : | | | | | : | | | | | | : | | | |
| | bright | 0 | 0 | 0 | 0 | 0 | 0 | 1 | 1 | 1 | 1 | 0 | 1 | 0 | 0 | 0 | 0 | 0 | 0 |
| | 0 | 0 | 0 | 0 | 0 | 0 | 1 | 1 | 1 | 1 | 1 | 0 | 0 | 0 | 0 | 0 | 0 | 0 | |
| Green | 0 | 0 | 0 | 0 | 0 | 0 | 1 | 1 | 1 | 1 | 1 | 1 | 0 | 0 | 0 | 0 | 0 | 0 | |
| Blue gray scale | Black | 0 | 0 | 0 | 0 | 0 | 0 | 0 | 0 | 0 | 0 | 0 | 0 | 0 | 0 | 0 | 0 | 0 | 0 |
| | | 0 | 0 | 0 | 0 | 0 | 0 | 0 | 0 | 0 | 0 | 0 | 0 | 0 | 0 | 0 | 0 | 0 | 1 |
| | dark | 0 | 0 | 0 | 0 | 0 | 0 | 0 | 0 | 0 | 0 | 0 | 0 | 0 | 0 | 0 | 0 | 1 | 0 |
| | ↑ | | | | : | | | | | : | | | | | | : | | | |
| | ↓ | | | | : | | | | | : | | | | | | : | | | |
| | bright | 0 | 0 | 0 | 0 | 0 | 0 | 0 | 0 | 0 | 0 | 0 | 0 | 1 | 1 | 1 | 1 | 0 | 1 |
| | 0 | 0 | 0 | 0 | 0 | 0 | 0 | 0 | 0 | 0 | 0 | 0 | 1 | 1 | 1 | 1 | 1 | 0 | |
| Blue | 0 | 0 | 0 | 0 | 0 | 0 | 0 | 0 | 0 | 0 | 0 | 0 | 1 | 1 | 1 | 1 | 1 | 1 | |

4.7 DISPLAY POSITIONS

The following table is the coordinates per pixel (See figure of "4.8 SCANNING DIRECTIONS").

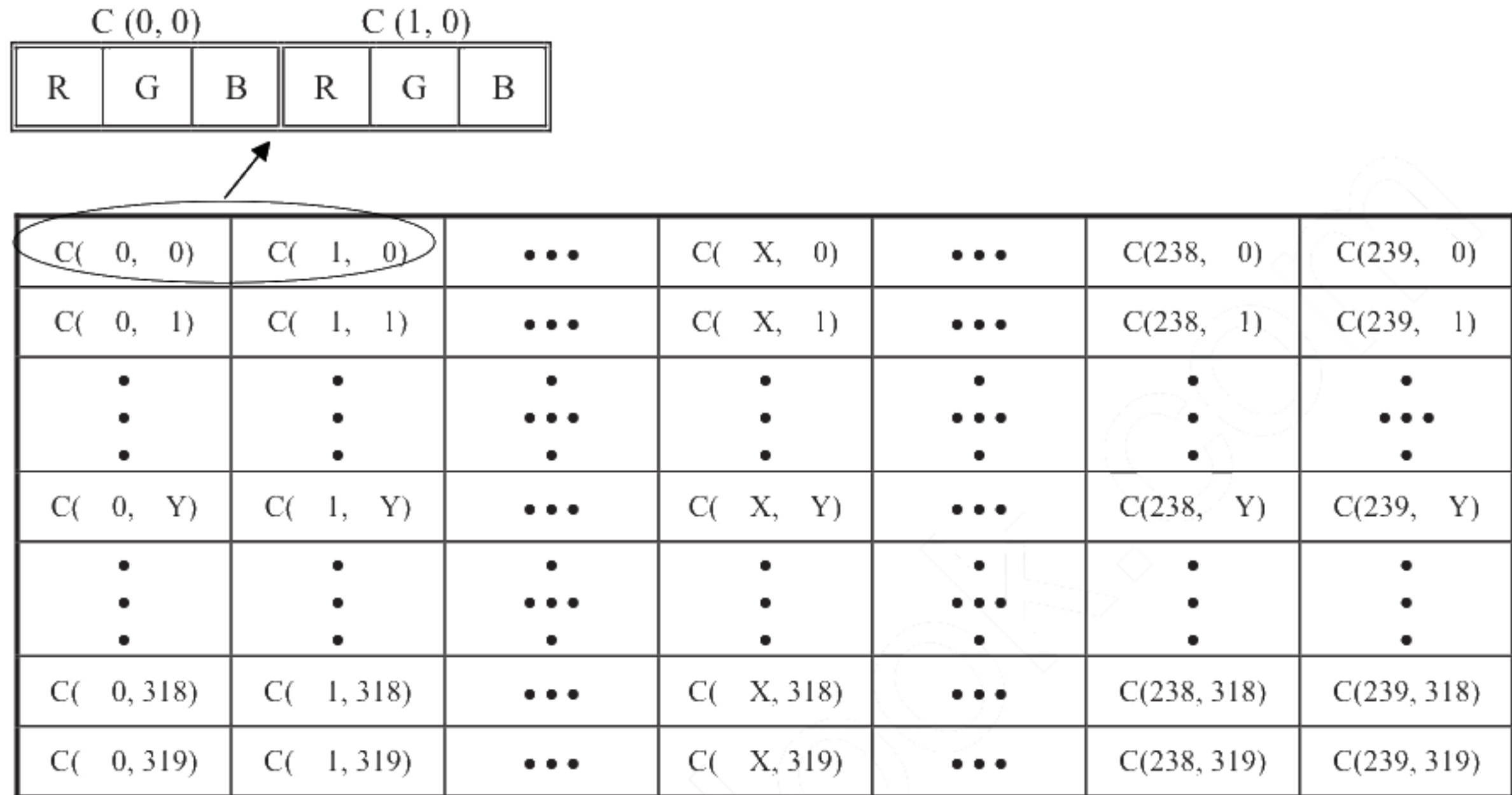

4.8 SCANNING DIRECTIONS

The following figures are seen from a front view. Also the arrow shows the direction of scan.

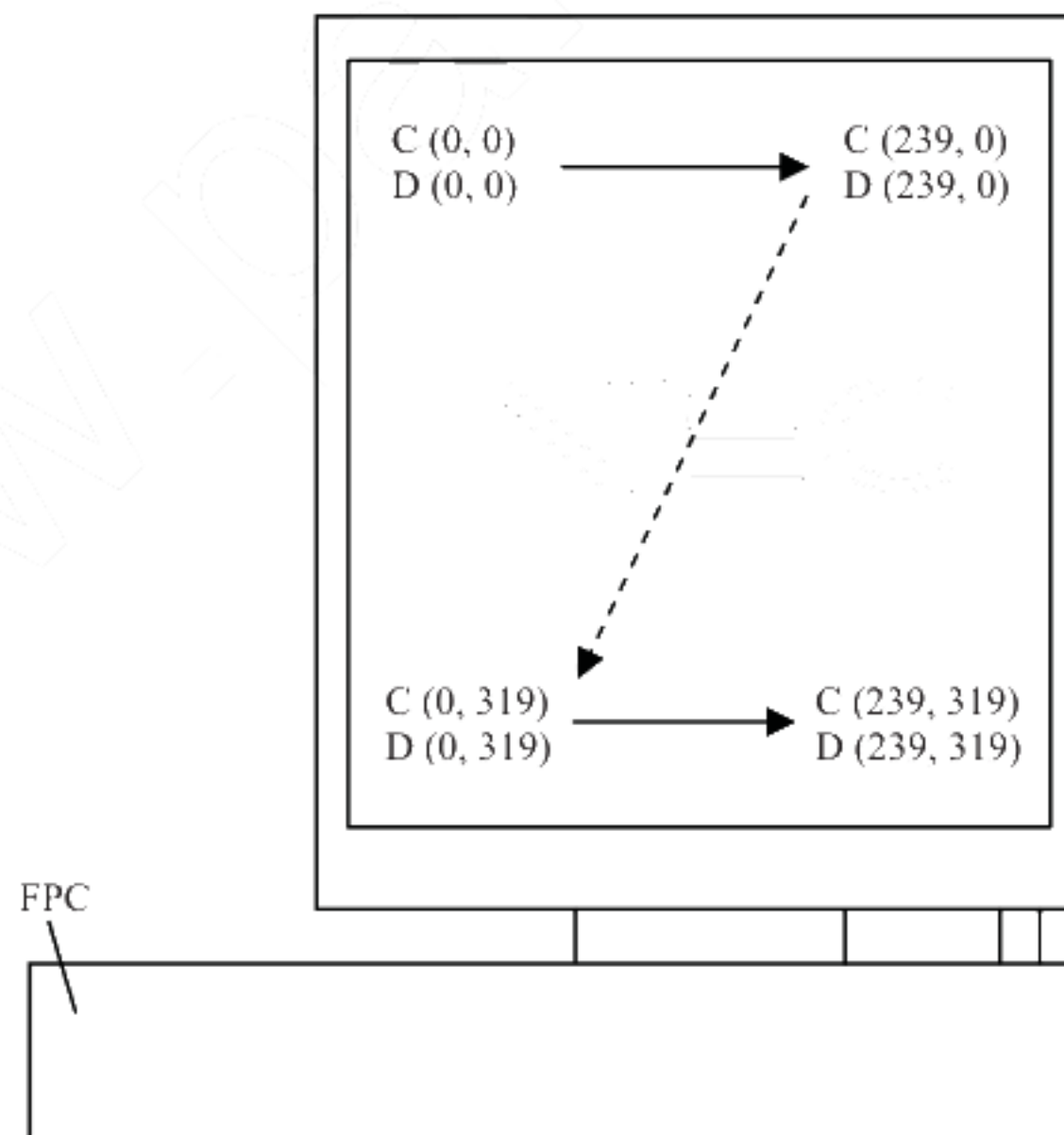

Note1: Meaning of C (X, Y) and D (X, Y)
 C (X, Y): The coordinates of the display position (See "4.7 DISPLAY POSITIONS".)
 D (X, Y): The data number of input signal for LCD panel

4.9 INPUT SIGNAL TIMINGS

4.9.1 RGB interface (Ta= 25°C, VCC= 3.0V)

(1) Timing characteristics

| Parameter | | Symbol | min. | typ. | max. | Unit | Remarks | |
|--|----------------------|------------|------|-------|-------|------|-----------------|---|
| CLK | Frequency | 1/tc | 4.81 | 5.0 | 5.12 | MHz | 200ns (typ.) | |
| | Duty | tcd | 0.4 | 0.5 | 0.6 | - | - | |
| | Rise time, Fall time | trf | - | - | 15 | ns | - | |
| DATA (D00-05) (D10-15) (D20-25) | CLK-DATA | Setup time | tds | 15 | - | - | ns | - |
| | | Hold time | tdh | 15 | - | - | ns | - |
| | Rise time, Fall time | trf | - | - | 15 | ns | - | |
| HSYNC | Cycle | th | 50.0 | 51.2 | 53.2 | μs | 19.53kHz (typ.) | |
| | | | 256 | | | CLK | - | |
| | Display period | thd | 240 | | | CLK | - | |
| | Front-porch | thf | 4 | | | CLK | - | |
| | Pulse width | thp | 2 | 8 | - | CLK | - | |
| | Back-porch | thb | 4 | | | CLK | - | |
| | CLK- HSYNC | Setup time | ths | 15 | - | - | ns | - |
| | | Hold time | thh | 15 | - | - | ns | - |
| Rise time, Fall time | thrf | - | - | 15 | ns | - | | |
| VSYNC | Cycle | tv | 16.2 | 16.59 | 17.24 | ms | 60Hz (typ.) | |
| | | | 324 | | | H | - | |
| | Display period | tvd | 320 | | | H | - | |
| | Front-porch | tvf | 1 | | | H | - | |
| | Pulse width | tvp | 1 | 2 | - | H | - | |
| | Back-porch | tvb | 1 | | | H | - | |
| | VSYNC-HSYNC timing | tvh | 15 | - | - | ns | - | |
| Rise time, Fall time | tvrf | - | - | 15 | ns | - | | |

Note1: Definition of parameters is as follows.

tc= 1CLK, tcd= tch/tc, th= 1H

Note2: All parameters should be kept within the specified range.

(2) Input signal timing chart

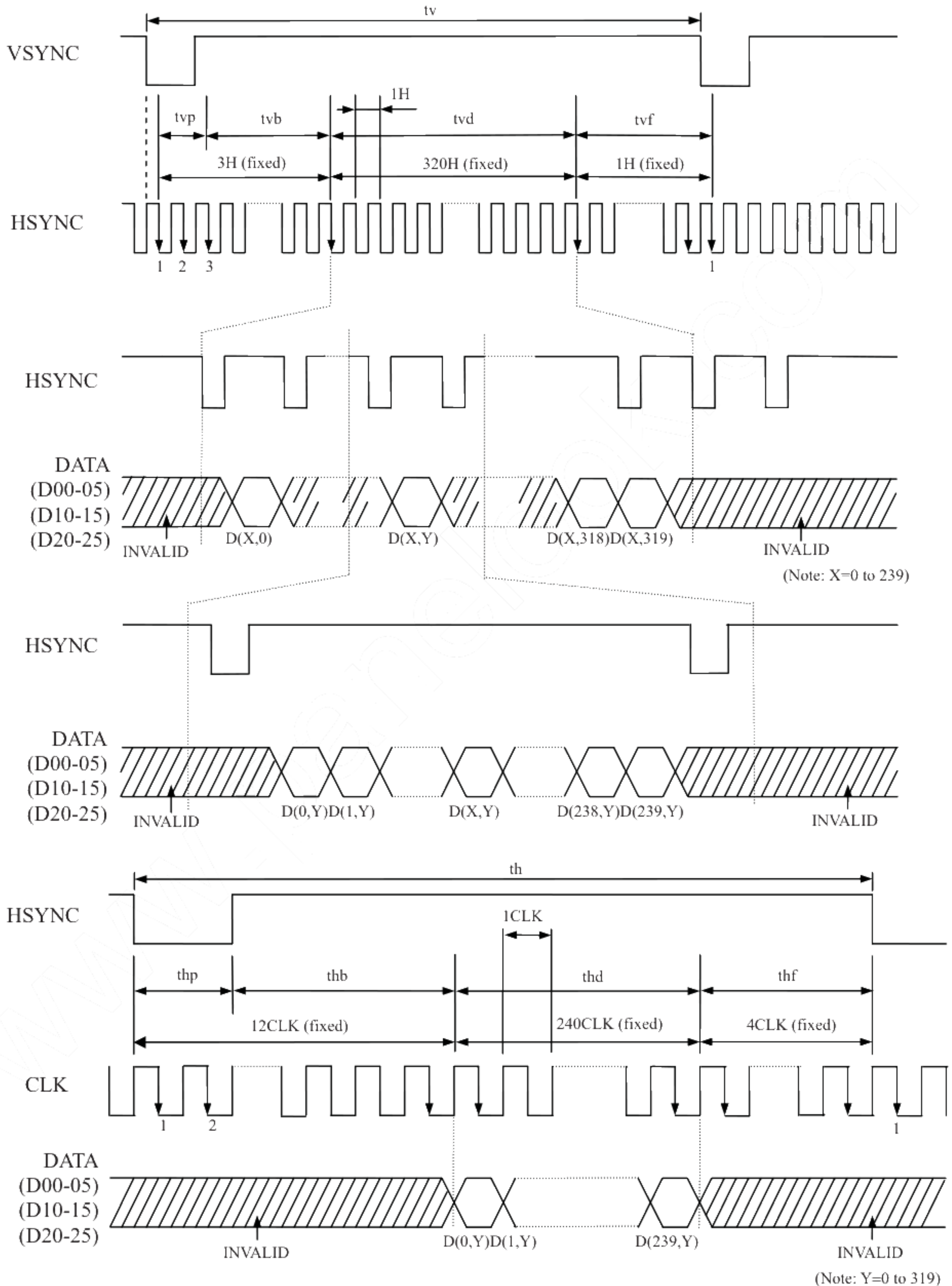

Note1: Unless otherwise specified, the input level is defined to be $V_{IH} = 0.8V_{CC}$, $V_{IL} = 0.2V_{CC}$.

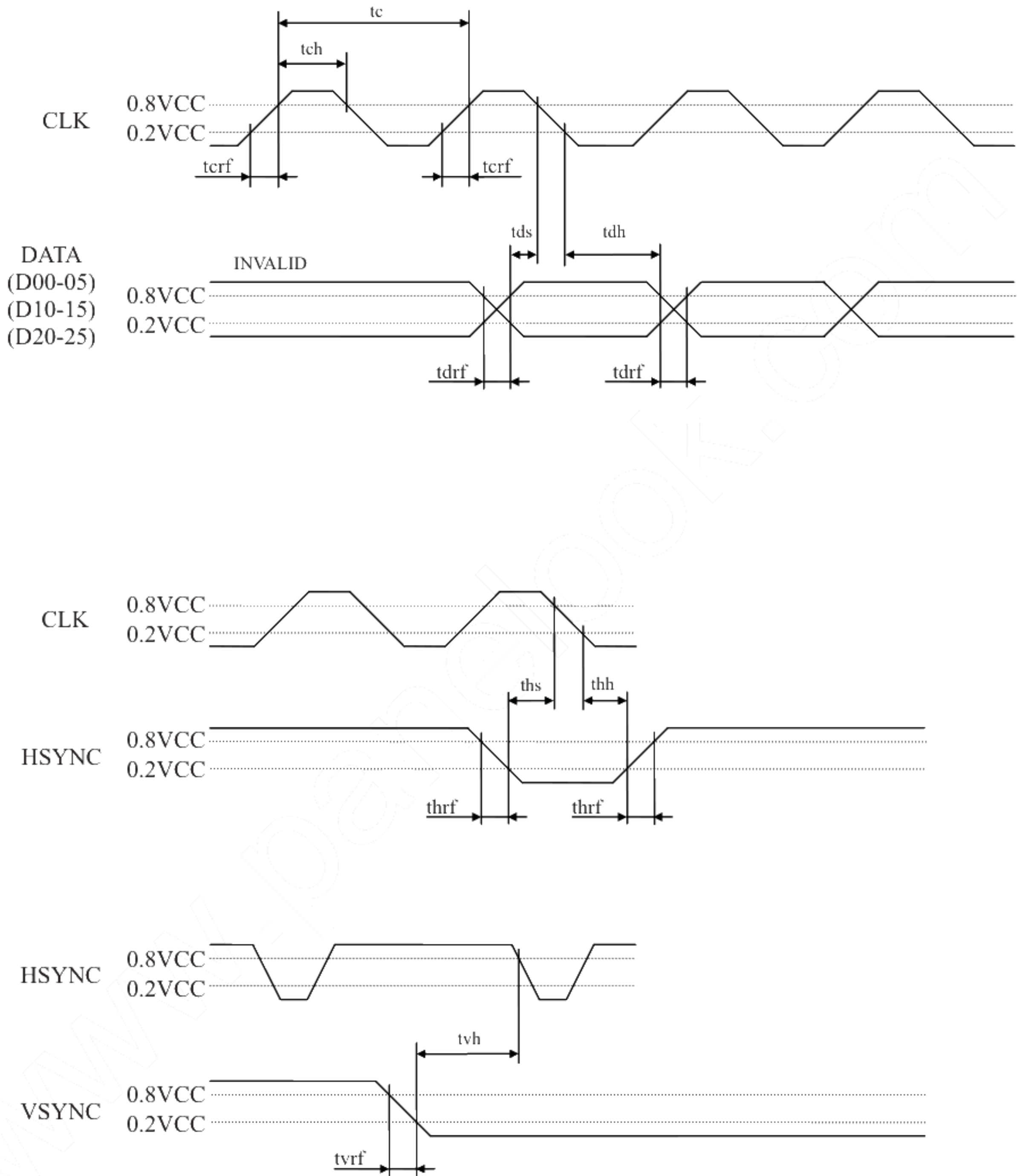

Note1: Unless otherwise specified, the input level is defined to be $V_{IH} = 0.8V_{CC}$, $V_{IL} = 0.2V_{CC}$.

4.9.2 Serial interface (Ta= 25°C, VCC= 3.0V)

(1) Timing characteristics

| Parameter | Symbol | Condition | min. | typ. | max. | Unit | Remarks |
|----------------------------|--------|----------------|------|------|------|------|---------|
| Serial clock cycle | tSCYC | READ | 450 | - | - | ns | - |
| | | WRITE | 100 | - | - | ns | - |
| SCL high level pulse width | tSHW | READ | 210 | - | - | ns | - |
| | | WRITE | 40 | - | - | ns | - |
| SCL low level pulse width | tSLW | READ | 210 | - | - | ns | - |
| | | WRITE | 40 | - | - | ns | - |
| /CS rise time, fall time | tcsrf | /CS | - | - | 15 | ns | - |
| SCL rise time, fall time | tscrf | SCL | - | - | 15 | ns | - |
| SI rise time, fall time | tsirf | SI | - | - | 15 | ns | - |
| /CS setup time | tCSS | /CS | 50 | - | - | ns | - |
| /CS hold time | tCSH | /CS | 30 | - | - | ns | - |
| Data setup time | tSDS | SI | 30 | - | - | ns | - |
| Data hold time | tSDH | SI | 15 | - | - | ns | - |
| Reset pulse width | tRW | /RESET | 2 | - | - | μs | - |
| /RESET↑ to /CS time | tRCS | /RESET↑ to /CS | 1 | - | - | ms | - |

Note1: All parameters should be kept within the specified range.

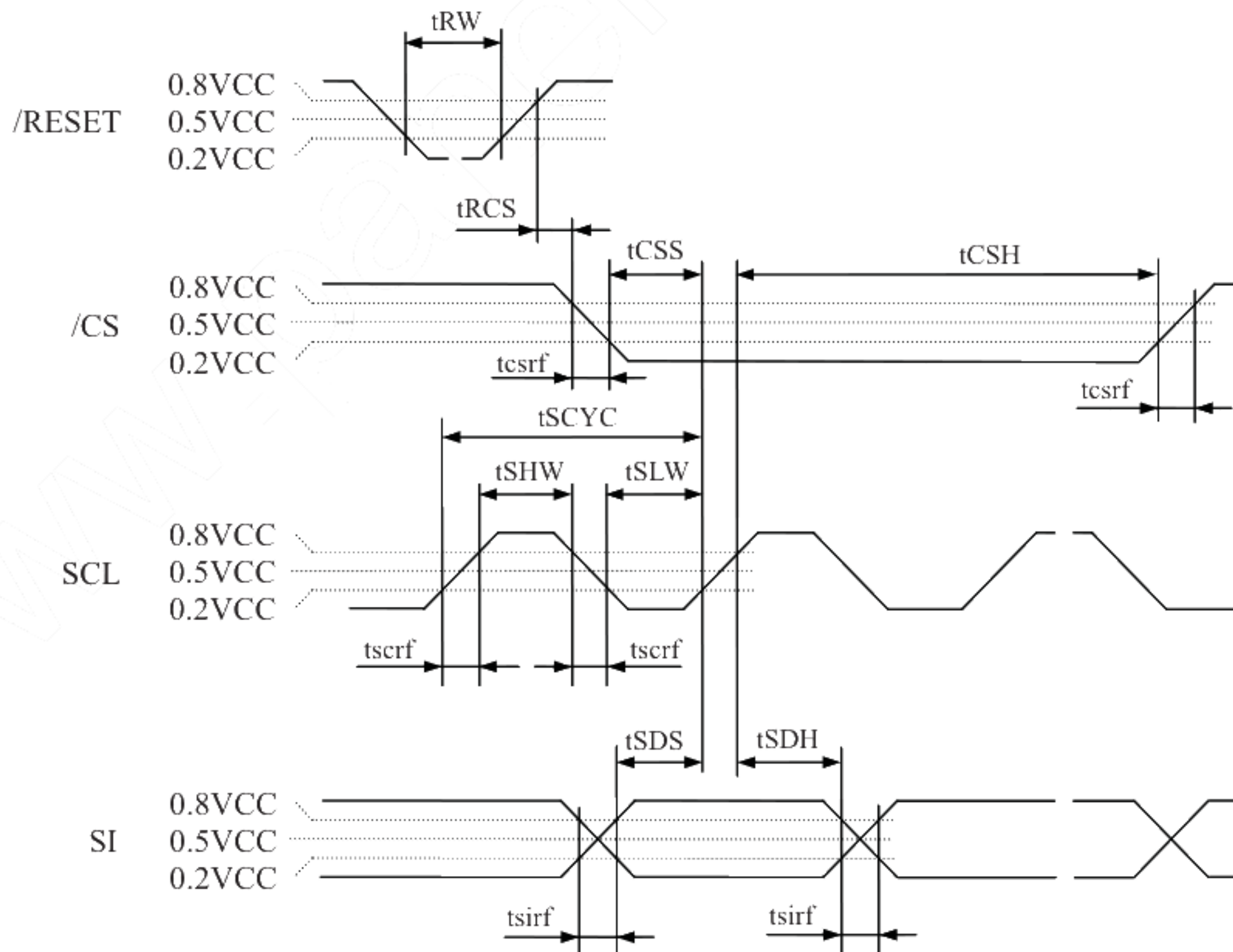

Note2: Unless otherwise specified, the input level is defined to be VIH= 0.8VCC, VIL= 0.2VCC.

4.10 OPTICAL CHARACTERISTICS

<Backlight turning OFF>

(Note1, Note3, Note4)

| Parameter | Condition | Symbol | min. | typ. | max. | Unit | Remarks |
|-------------------|------------------------|--------|------|------|------|------|---------|
| Reflectance ratio | White, at center | RE | 10 | 15 | - | % | Note6 |
| Contrast ratio | White/Black, at center | CR | 10 | 15 | - | - | Note7 |

Reference data

(Note1, Note3, Note4)

| Parameter | Condition | Symbol | min. | typ. | max. | Unit | Remarks |
|--------------------------|-------------------------------------|---------|------|------|------|------|-----------------------|
| Chromaticity coordinates | White | Wx | - | 0.32 | - | - | Note8 |
| | | Wy | - | 0.34 | - | - | |
| Color gamut | at center, against NTSC color space | C | - | 5 | - | % | |
| Response time | White to black | 90%→10% | Ton | - | 7 | 14 | ms Note9 Note10 |
| | Black to white | 10%→90% | Toff | - | 9 | 18 | |

<Backlight turning ON>

(Note2, Note3, Note5)

| Parameter | Condition | Symbol | min. | typ. | max. | Unit | Remarks |
|----------------------|--|--------|------|------|------|-------------------|---------|
| Luminance | White at center $\theta R=0^\circ, \theta L=0^\circ, \theta U=0^\circ, \theta D=0^\circ$ | L | 150 | 220 | - | cd/m ² | - |
| Contrast ratio | White/Black at center $\theta R=0^\circ, \theta L=0^\circ, \theta U=0^\circ, \theta D=0^\circ$ | CR | 75 | 150 | - | - | Note7 |
| Luminance uniformity | White $\theta R=0^\circ, \theta L=0^\circ, \theta U=0^\circ, \theta D=0^\circ$ Maximum luminance: 100% | LU | 60 | 70 | - | % | Note11 |

Reference data

(Note2, Note3, Note5)

| Parameter | Condition | Symbol | min. | typ. | max. | Unit | Remarks |
|--------------------------|---|---|------------|------|------|------|-----------------------|
| Chromaticity coordinates | White | Wx | 0.25 | 0.30 | 0.35 | - | Note8 |
| | | Wy | 0.27 | 0.32 | 0.37 | - | |
| Color gamut | $\theta R=0^\circ, \theta L=0^\circ, \theta U=0^\circ, \theta D=0^\circ$ at center, against NTSC color space | C | - | 40 | - | % | |
| Response time | White to black | 90%→10% | Ton | - | 7 | 14 | ms Note9 Note10 |
| | Black to white | 10%→90% | Toff | - | 23 | 46 | |
| Viewing angle | Right | $\theta U=0^\circ, \theta D=0^\circ, CR \geq 5$ | θR | - | 35 | - | ° |
| | Left | $\theta U=0^\circ, \theta D=0^\circ, CR \geq 5$ | θL | - | 35 | - | ° |
| | Up | $\theta R=0^\circ, \theta L=0^\circ, CR \geq 5$ | θU | - | 35 | - | ° |
| | Down | $\theta R=0^\circ, \theta L=0^\circ, CR \geq 5$ | θD | - | 35 | - | ° |

Note1: Measurement conditions are as follows.
 Ta= 25 °C, VCC= 3.0V

Note2: Measurement conditions are as follows.
 Ta= 25 °C, VCC= 3.0V, IL= 20mA

Note3: Definition of viewing angles

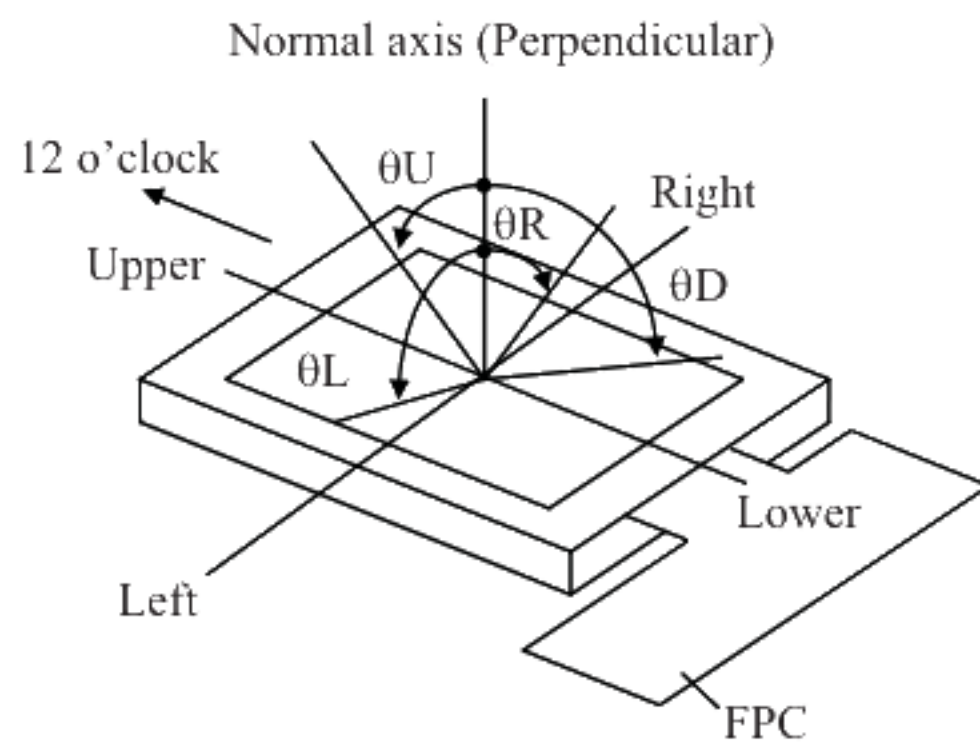

Note4: In reflective mode (Backlight turning OFF), Reflectance ratio, Contrast ratio, Chromaticity coordinates and Color gamut are measured as follows.

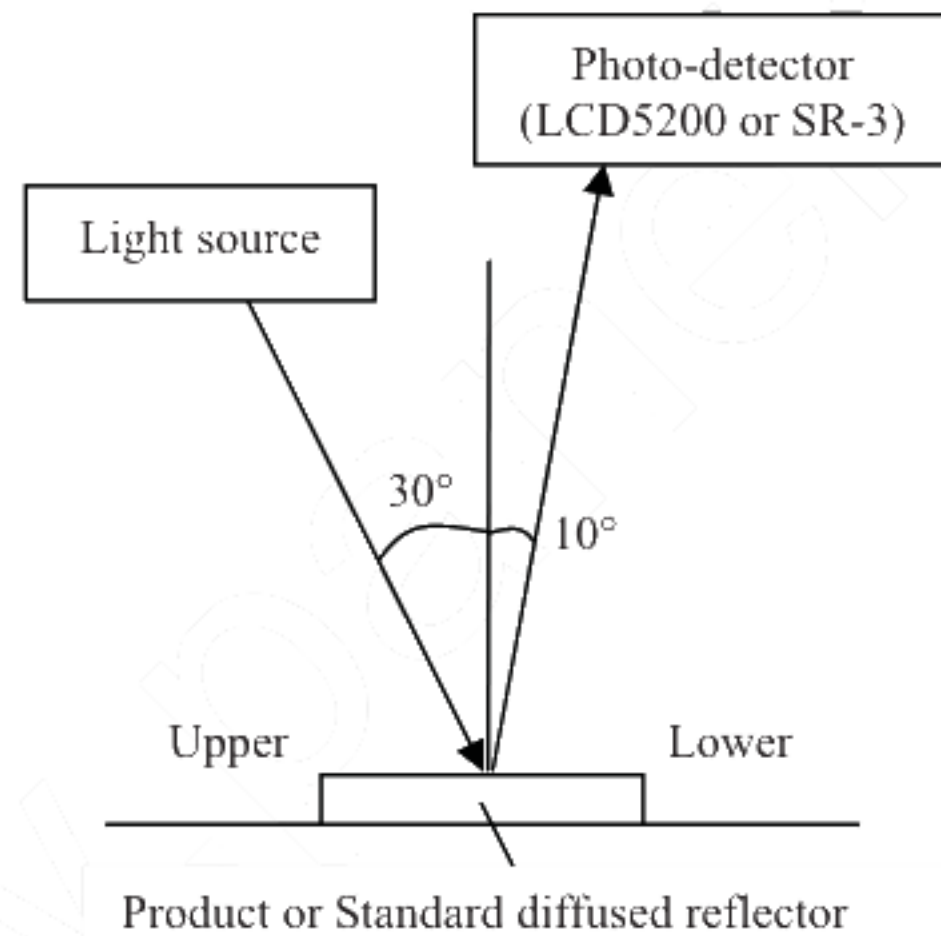

Note5: In transmissive mode (Backlight turning ON), Luminance, Contrast ratio, Chromaticity coordinates and Color gamut are measured as follows.

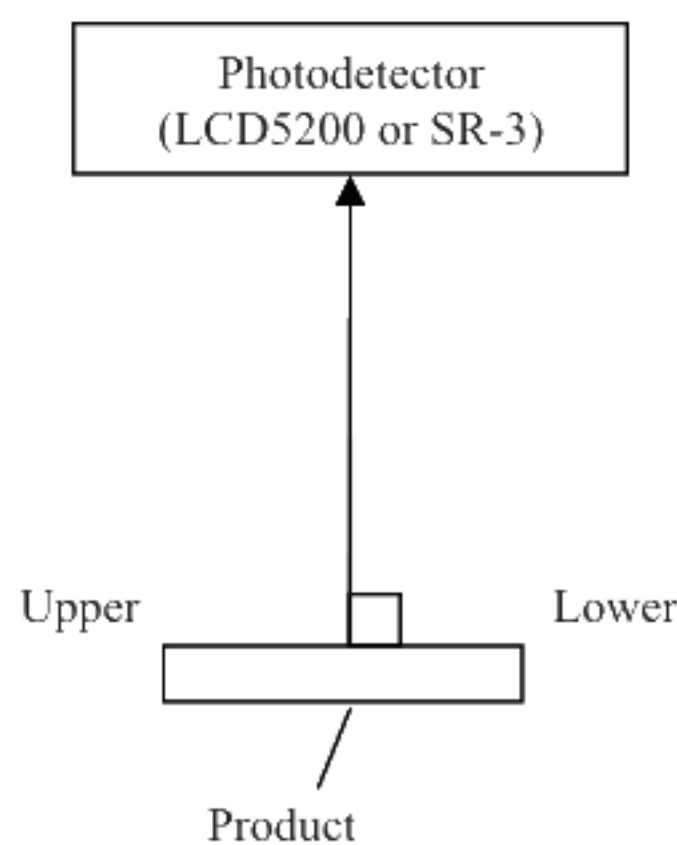

Note6: Definitions of reflectance ratio

The reflectance ratio is calculated by using the following formula.

$$\text{Reflectance (RE)} = \frac{\text{Luminance of reflected light at white screen}}{\text{Luminance of standard diffused reflector}} \times 100$$

Note7: Definition of contrast ratio

The contrast ratio is calculated by using the following formula.

$$\text{Contrast ratio (CR)} = \frac{\text{Luminance of white screen}}{\text{Luminance of black screen}}$$

Note8: The White chromaticity coordinates are deviated by the LED deviation in addition to color filter deviation.

Note9: Definition of response times

Response time is measured, the luminance changes from "white" to "black", or "black" to "white" on the same screen point, by photo-detector. Ton is the time it takes the luminance change from 90% down to 10%. Also Toff is the time it takes the luminance change from 10% up to 90% (See the following diagram.).

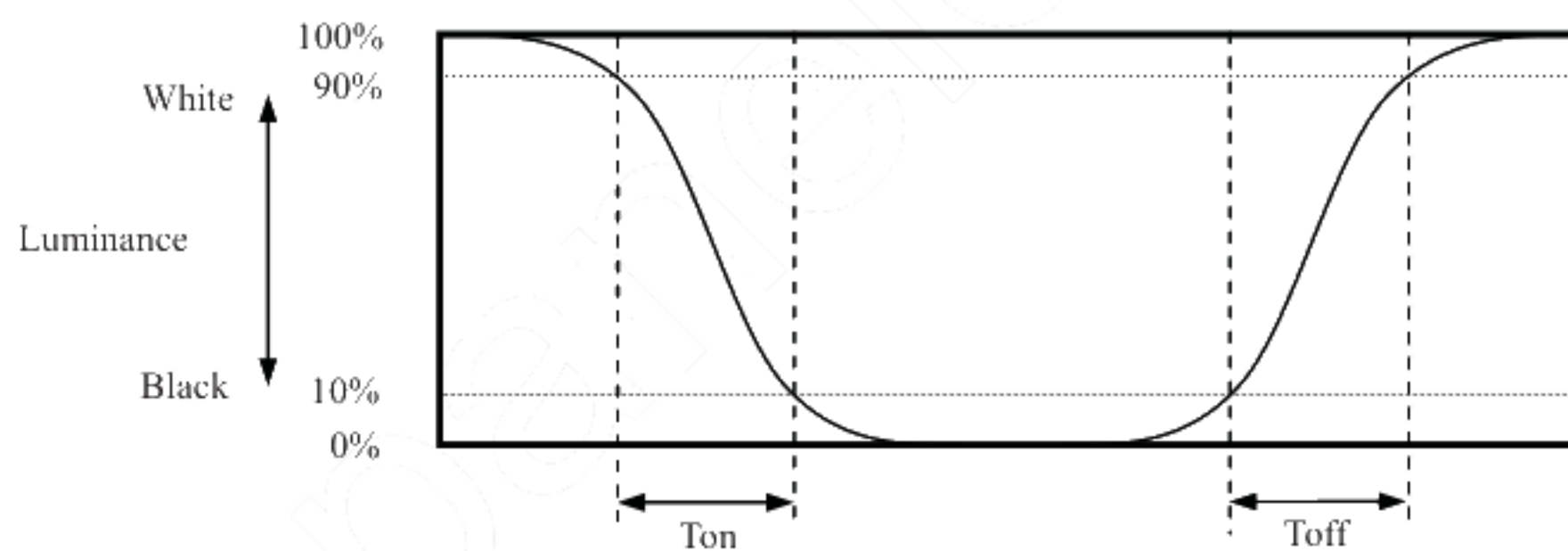

Note10: Product surface temperature: Top= 25°C

Note11: Definition of luminance uniformity

Luminance uniformity is calculated by using the following formula.

$$\text{Luminance uniformity (LU)} = \frac{\text{Minimum luminance from A to I}}{\text{Maximum luminance from A to I}} \times 100$$

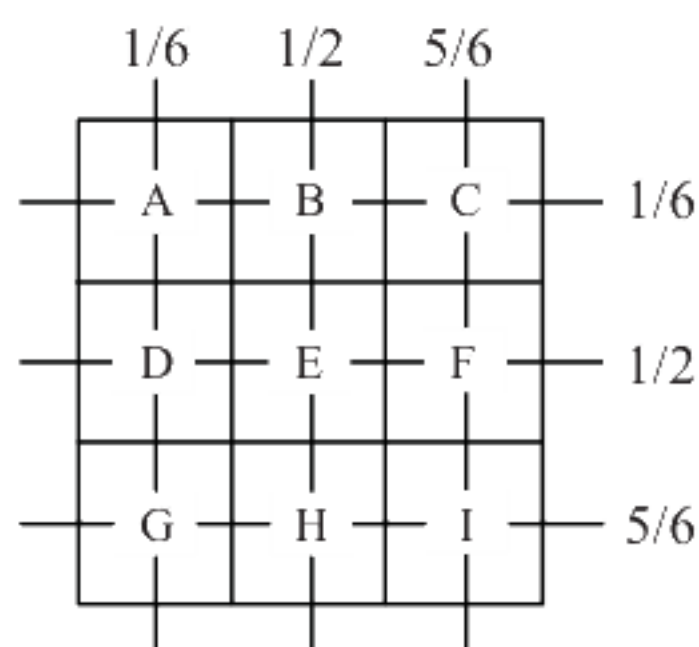

5. RELIABILITY TESTS

| Test item | Condition | Judgement Note1 |
|--|---|-------------------------|
| High temperature and humidity (Operation) | ① $55 \pm 2^{\circ}\text{C}$, RH = 85%, 240 hours ② Display data is black. | No display malfunctions |
| Heat cycle (Operation) | ① $-20 \pm 3^{\circ}\text{C}$...1 hour $70 \pm 3^{\circ}\text{C}$...1 hour ② 50 cycles, 4 hours/cycle ③ Display data is black. | |
| Thermal shock (Non operation) | ① $-20 \pm 3^{\circ}\text{C}$...30 minutes $70 \pm 3^{\circ}\text{C}$...30 minutes ② 100 cycles, 1 hour/cycle ③ Temperature transition time is within 5 minutes. | |
| Low pressure (Non operation) | ① 15kPa ② $-20 \pm 3^{\circ}\text{C}$...24 hours ③ $70 \pm 3^{\circ}\text{C}$...24 hours | |
| Low pressure (Operation) | ① 53.3 kPa ② $-20 \pm 3^{\circ}\text{C}$...24 hours ③ $70 \pm 3^{\circ}\text{C}$...24 hours | |
| ESD (Operation) | ① 150pF, 150Ω, ±10kV ② 3 places on a panel surface ③ 10 times each places at 1 sec interval | |
| Dust (Operation) | ① Sample dust: No. 15 (by JIS-Z8901) ② 15 seconds stir ③ 8 times repeat at 1 hour interval | |
| Vibration (Operation) | ① 30 to 100Hz, 19.6m/s^2 ② 30 minutes/cycle ③ X, Y, Z direction ④ 1 times each directions | |
| Mechanical shock (Non operation) | ① $3,920\text{m/s}^2$, 2.5ms ② ±X, ±Y, ±Z direction ③ 1 times each directions | |

Note1: Display and appearance are checked under environmental conditions equivalent to the inspection conditions of defect specifications.

6. PRECAUTIONS

6.1 MEANING OF CAUTION SIGNS

The following caution signs have very important meaning. **Be sure to read "6.2 CAUTIONS" and "6.3 ATTENTIONS", after understanding these contents!**

 This sign has the meaning that customer will be injured by himself or the product will sustain a damage, if customer has wrong operations.

 This sign has the meaning that customer will get an electrical shock, if customer has wrong operations.

 This sign has the meaning that customer will be injured by himself, if customer has wrong operations.

6.2 CAUTIONS

 *** Do not touch the working backlight. There is a danger of an electric shock.**

 *** Do not touch the working backlight. There is a danger of burn injury.**
*** Do not shock and press the LCD panel and the backlight! There is a danger of breaking, because they are made of glass. (Shock: To be not greater 3,920m/s² and to be not greater 2.5ms)**

6.3 ATTENTIONS 

6.3.1 Handling of the product

- ① Take hold of both ends without touching the FPC when the product (LCD module) is picked up from the tray.
- ② Do not hook nor pull the FPC in order to avoid any damage.
- ③ When the product is put on the table temporarily, display surface must be placed downward.
- ④ When handling the product, take the measures of electrostatic discharge with such as earth band, ionic shower and so on, because the product may be damaged by electrostatic.
- ⑤ The product must be installed and/or handled without undue stress such as bends or twist. Bends, twist or undue stress to any portion may cause display failures. And also do not put heavy or hard materials on the product. ☆
- ⑥ Do not hit or rub the surface of panel with hard materials, because it is easily scratched. (Polarizer pencil-hardness: 3H) ☆
- ⑦ When cleaning the panel surface, wipe it with a soft dry cloth.
- ⑧ Do not push nor pull the FPC while the product is working.
- ⑨ Do not fold the FPC. When the FPC is folded, pattern disconnection may be caused. In case of bending FPC, the minimum curvature (R) must be more than 1.0 mm.
- ⑩ When installing the product, do not contact a conductor such as a metal to the FPC excluding the terminal area. There is a risk of short circuit which is caused by breakage of insulation layer of the FPC.
- ⑪ When installing the product, apply the waterproof design to avoid going of water into the product.

6.3.2 Environment

- ① Do not operate or store in high temperature, high humidity, dewdrop atmosphere or corrosive gases. Keep the product in packing box with antistatic pouch in room temperature to avoid dusts and sunlight, when storing the product.
- ② In order to prevent dew condensation occurring by temperature difference, the product packing box should be opened after enough time being left under the environment of an unpacking room. Evaluate the leaving time sufficiently because a situation of dew condensation occurring is changed by the environmental temperature and humidity. (Recommended leaving time: 6 hours or more with packing state)
- ③ Do not operate in high magnetic field. Circuits may be broken down by it.
- ④ This product is not designed as radiation hardened.

6.3.3 Characteristics

The following items are neither defects nor failures.

- ① Response time, luminance and color may be changed by ambient temperature.
- ② Display mura, flicker, vertical seam or small spot may be observed depending on display patterns.
- ③ Do not display the fixed pattern for a long time because it may cause image sticking.
- ④ Optical characteristics may be changed depending on input signal timings.

6.3.4 Other

- ① All GND terminals should be used without any non-connected lines.
- ② Do not disassemble the product.
- ③ Pack the product with original shipping package, in order to avoid any damages during transportation, when returning the product to NEC.

7. OUTLINE DRAWINGS

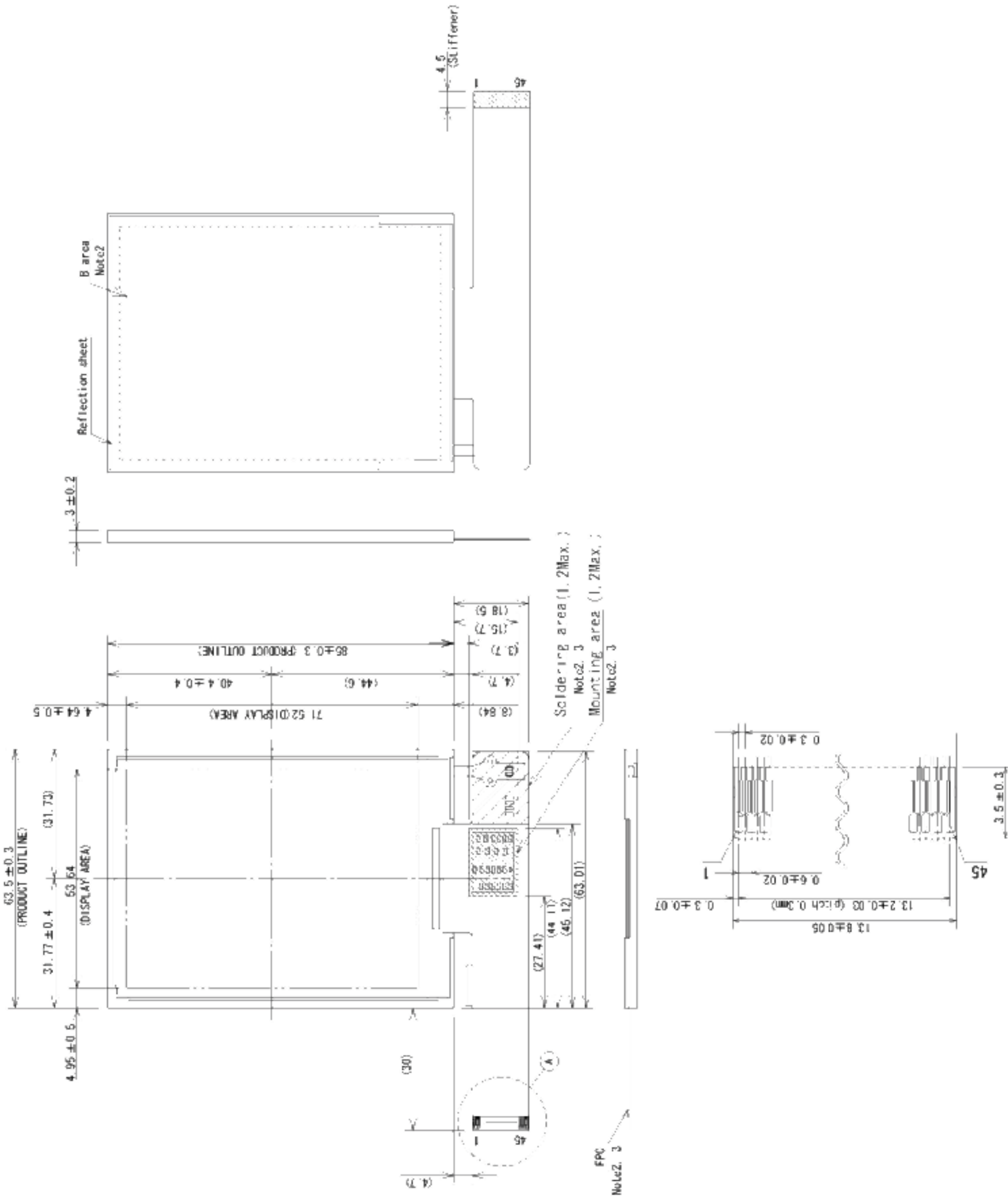

| Pin No. | Symbols | Pin No. | Symbols |
|---------|---------|---------|---------|
| 1 | GND | 25 | D20 |
| 2 | GND | 26 | D21 |
| 3 | VCC | 27 | D22 |
| 4 | VCC | 28 | D23 |
| 5 | VCC | 29 | D24 |
| 6 | VCC | 30 | D25 |
| 7 | GND | 31 | GND |
| 8 | /RESET | 32 | SCL |
| 9 | HSYNC | 33 | SI |
| 10 | VSYNC | 34 | RSVD |
| 11 | CLK | 35 | /CS |
| 12 | GND | 36 | VCOMIN |
| 13 | D00 | 37 | N.C. |
| 14 | D01 | 38 | GND |
| 15 | D02 | 39 | N.C. |
| 16 | D03 | 40 | N.C. |
| 17 | D04 | 41 | N.C. |
| 18 | D05 | 42 | N.C. |
| 19 | D10 | 43 | GND |
| 20 | D11 | 44 | ANODE |
| 21 | D12 | 45 | CATHODE |
| 22 | D13 | | |
| 23 | D14 | | |
| 24 | D15 | | |

Adaptable connector FH23-45S-0.3SHW (05) (HRS)

Detail A

- Note1: The values in parentheses are for reference.
- Note2: When installing the product to the customer equipment, do not apply undue stress to the B area, FPC, Soldering Area and Mounting Area. If not, it may cause display un-uniformity or break down of the product.
- Note3: While the product is working, do not contact a conductor such as a metal to the Soldering Area and Mounting Area of the FPC.

Unit: mm