

|                    |  |  |
|--------------------|--|--|
| PREPARED BY : DATE | <br>DISPLAY DEVICE BUSINESS GROUP<br>SHARP CORPORATION<br><b>SPECIFICATION</b> | SPEC No. LD-23812A                               |
| APPROVED BY : DATE |  | FILE No. LD-23812A                               |
|                    |  | ISSUE : 01-Sep-11<br>PAGE : 20pages              |
|                    |  | APPLICABLE GROUP<br>LIQUID CRYSTAL DISPLAY GROUP |

REVISION : 1-Sep-11

DEVICE SPECIFICATION FOR

**TFT-LCD Module**

MODEL No.

**LQ104V1DG81**

These parts have corresponded with the RoHS

CUSTOMER'S APPROVAL  
BY \_\_\_\_\_

BY   
 J.Kawanishi  
 GENERAL MANAGER  
 ENGINEERING DEPARTMENT I  
 LIQUID CRYSTAL DISPLAY DIVISION III  
 DISPLAY DEVICE BUSINESS GROUP  
 SHARP CORPORATION

# RECORDS OF REVISION

LQ104V1DG81

| SPEC No.  | DATE     | REVI<br>SED<br>No | PAGE | SUMMARY | NOTE |
|-----------|----------|-------------------|------|---------|------|
| LD-23812A | 2011/9/1 |                   |      | -       |      |
|           |          |                   |      |         |      |

| No.   |   | page |
|-------|---|------|
| 1     | Application .....   | 1    |
| 2     | Overview .....  | 2    |
| 3     | Mechanical Specifications .....                                     | 2    |
| 4     | Input Terminals .....   | 3    |
| 5     | Absolute Maximum Ratings .....                                      | 4    |
| 6     | Electrical Characteristics .....                                    | 5    |
| 7     | Timing characteristics of input signals .....                       | 7    |
| 8     | Input Signals, Basic Display Colors and Gray Scale of Each Color .. | 9    |
| 9     | Optical Characteristics .....                                       | 10   |
| 10    | Handling Precautions .....  | 12   |
| 11    | Packing form .....  | 13   |
| 12    | Reliability test items .....  | 13   |
| 13    | Others .....  | 14   |
| 14    | Storage conditions .....  | 15   |
| Fig.1 | Outline Dimensions .....  | 16   |
| Fig.3 | PACKING FORM .....  | 17   |

## 1. Application

This specification applies to the color TFT-LCD module LQ104V1DG81.

This specification is the proprietary product of SHARP CORPORATION (SHARP) and include materials protected under copyright of SHARP. Do not reproduce or cause any third party to reproduce them in any form or by any means, electronic or mechanical, for any purpose, in whole or in part, without the express written permission of SHARP.

The device listed in this specification was designed and manufactured for use in general electronic equipment.

In case of using the device for applications such as control and safety equipment for transportation (controls of aircraft, trains, automobiles, etc.), rescue and security equipment and various safety related equipment which require higher reliability and safety, take into consideration that appropriate measures such as fail-safe functions and redundant system design should be taken.

Do not use the device for equipment that requires an extreme level of reliability, such as aerospace applications, telecommunication equipment (trunk lines), nuclear power control equipment and medical or other equipment for life support.

SHARP assumes no responsibility for any damage resulting from the use of the device which does not comply with the instructions and the precautions specified in this specification .

Contact and consult with a SHARP sales representative for any questions about this device.

## 2. Overview

This module is a color active matrix LCD module incorporating amorphous silicon TFT (Thin Film Transistor). It is composed of a color TFT-LCD panel, driver ICs, control circuit, power supply circuit and a White-LED Backlight unit. Graphics and texts can be displayed on a 640 × RGB × 480dots panel with about 262,144 colors by using CMOS(Complementary MOS) and supplying +3.3V DC supply voltages for TFT-LCD panel driving and supply voltage for backlight.

The TFT-LCD panel used for this module is a low-reflection and higher-color-saturation type.

Therefore, this module is also suitable for the multimedia use.

The maximum viewing angle is in the 6 o'clock direction.

The 12 o'clock direction is difficult to reverse the grayscale.

The LED driver circuit and the PWM circuit to drive the backlight are built into the module.

## 3. Mechanical technical literatures

| Parameter               | technical literatures                 | Unit  |
|-------------------------|---------------------------------------|-------|
| Display size            | 26(10.4inch) Diagonal                 | cm    |
| Active area             | 211.2(H) × 158.4(V)                   | mm    |
| Pixel format            | 640(H) × 480(V)<br>(1pixel=R+G+B dot) | pixel |
| Aspect ratio            | 4:3                                   |       |
| Pixel pitch             | 0.33(H) × 0.33(V)                     | mm    |
| Pixel configuration     | R,G,B vertical stripe                 |       |
| Display mode            | Normally white                        |       |
| Unit outline dimensions | 246.5(W) × 179.4(H) × 12.5(D)         | mm    |
| Mass                    | 500                                   | g     |
| Surface treatment       | Anti-glare and hard-coating 3H        |       |

Outline dimensions are shown in Fig.1.

## 4. Input Terminals

### 4-1. TFT-LCD panel driving

CN1 (Interface signals and +3.3V power supply)

|                          |                                     |                |
|--------------------------|-------------------------------------|----------------|
|                          | Hirose Electric Co., Ltd.           | I-PEX          |
| Using connectors         | DF9MA-31P-1V(32)<br>DF9B-31P-1V(32) | 20026-231*-*1F |
| Corresponding connectors | DF9* -31S-1V(32)                    | 20027-*31*-*1F |

| Pin | Symbol | Function   | Remark   |
|-----|--------|--|----------|
| 1   | GND    | GND  |          |
| 2   | CK     | Clock signal for sampling each data signal       |          |
| 3   | Hsync  | Horizontal synchronous signal                    | Negative |
| 4   | Vsync  | Vertical synchronous signal                      | Negative |
| 5   | GND    | GND  |          |
| 6   | R0     | RED data signal(LSB)                             |          |
| 7   | R1     | RED data signal                                  |          |
| 8   | R2     | RED data signal                                  |          |
| 9   | R3     | RED data signal                                  |          |
| 10  | R4     | RED data signal                                  |          |
| 11  | R5     | RED data signal(MSB)                             |          |
| 12  | GND    | GND  |          |
| 13  | G0     | GREEN data signal(LSB)                           |          |
| 14  | G1     | GREEN data signal                                |          |
| 15  | G2     | GREEN data signal                                |          |
| 16  | G3     | GREEN data signal                                |          |
| 17  | G4     | GREEN data signal                                |          |
| 18  | G5     | GREEN data signal(MSB)                           |          |
| 19  | GND    | GND  |          |
| 20  | B0     | BLUE data signal(LSB)                            |          |
| 21  | B1     | BLUE data signal                                 |          |
| 22  | B2     | BLUE data signal                                 |          |
| 23  | B3     | BLUE data signal                                 |          |
| 24  | B4     | BLUE data signal                                 |          |
| 25  | B5     | BLUE data signal(MSB)                            |          |
| 26  | GND    | GND  |          |
| 27  | ENAB   | Signal to settle the horizontal display position | 【Note 1】 |
| 28  | Vcc    | +3.3V power supply                               |          |
| 29  | Vcc    | +3.3V power supply                               |          |
| 30  | NC     | display mode select signal                       |          |
| 31  | SCAN   | Horizontal/Vertical display mode select signal   | 【Note2】  |

【Note1】 The horizontal display start timing is settled in accordance with a rising timing of ENAB signal. In case ENAB is fixed "Low", the horizontal start timing is determined as described in 7-1. Don't keep ENAB "High" during operation.



## 4-2. LED backlight

LED backlight connector

CN2 Used connector : SM06B-SHLS-TF ( J.S.T. Mfg. Co. Ltd )

Corresponding connector : SHLP-06V-S-B ( J.S.T. Mfg. Co. Ltd )

| Connector No. | Pin No. | Symbol | Function                |
|---------------|---------|--------|-------------------------|
| CN2           | 1       | VDD    | +12V power supply       |
|               | 2       | VDD    | +12V power supply       |
|               | 3       | GND    | GND                     |
|               | 4       | GND    | GND                     |
|               | 5       | XSTABY | Backlight ON/OFF signal |
|               | 6       | VBR    | PWM signal              |

## 5. Absolute Maximum Ratings

| Parameter             | Symbol           | Condition            | Pin   | Ratings                   | Unit | Remark      |
|-----------------------|------------------|----------------------|---|---------------------------|------|-------------|
| Supply voltage        | V <sub>CC</sub>  | T <sub>a</sub> =25°C | VCC   | -0.3 ~ +4.0               | V    | 【Note1,2】   |
|                       | V <sub>DD</sub>  | T <sub>a</sub> =25°C | VDD   | -0.3 ~ +15.0              | V    | 【Note1,2】   |
| Input voltage         | V <sub>I1</sub>  | T <sub>a</sub> =25°C | R0-5,G0-5,B0-5<br>CK,Hsync,Vsync<br>ENAB,SCAN | -0.3~V <sub>CC</sub> +0.3 | V    |             |
|                       | V <sub>I4</sub>  | T <sub>a</sub> =25°C | XSTABY, VBR                                   | -0.3~+VDD                 | V    |             |
| Storage temperature   | T <sub>STG</sub> | —                    | —   | -30 ~ +80                 | °C   | 【Note1】     |
| Operating temperature | T <sub>OPA</sub> | —                    | —   | -30 ~ +80                 | °C   | 【Note1,3,4】 |

【Note1】 Humidity : 95%RH Max.( T<sub>a</sub> ≤ 40°C ) Note static electricity.

Maximum wet-bulb temperature at 39°C or less. (T<sub>a</sub> > 40°C) No condensation.

【Note2】 The V<sub>CC</sub> power supply capacity must use the one of 2A or more.

The V<sub>CC</sub> power supply capacity must use the one of 3A or more.

【Note3】 There is a possibility of causing deterioration in the irregularity and others of the screen and the display fineness though the liquid crystal module doesn't arrive at destruction when using it at 65~80°C.

【Note4】 In the operating temperature item, the low temperature side is the ambient temperature regulations.

The high temperature side is the panel surface temperature regulations.

## 6. Electrical Characteristics

### 6-1. TFT-LCD panel driving

$T_a = +25^\circ\text{C}$

| Parameter                       | Symbol   | Condition            | Min. | Typ. | Max. | Unit              | Remark                          |
|---------------------------------|----------|----------------------|------|------|------|-------------------|---------------------------------|
| Supply voltage                  | $V_{CC}$ |                      | 3.0  | 3.3  | 3.6  | V                 | 【Note1】                         |
| Current dissipation             | $I_{CC}$ | $V_{CC}=3.3\text{V}$ | -    | 230  | 300  | mA                | 【Note2】                         |
| Permissive input ripple voltage | $V_{RP}$ |                      | -    | -    | 100  | mV <sub>P-P</sub> | $V_{CC} = 3.3\text{V}$          |
| Input voltage                   | $V_{IH}$ |                      | 2.1  | -    | -    | V                 | 【Note3】                         |
|                                 | $V_{IL}$ |                      | -    | -    | 0.8  | V                 |                                 |
| Input leak current              | $I_{OH}$ |                      | -    | -    | 400  | $\mu\text{A}$     | $V_{I1} = +3.3\text{V}$ 【Note3】 |
|                                 | $I_{OL}$ |                      | -400 | -    | -    | $\mu\text{A}$     | $V_{I1} = 0\text{V}$ 【Note3】    |

【Note1】 On-off conditions for supply voltage

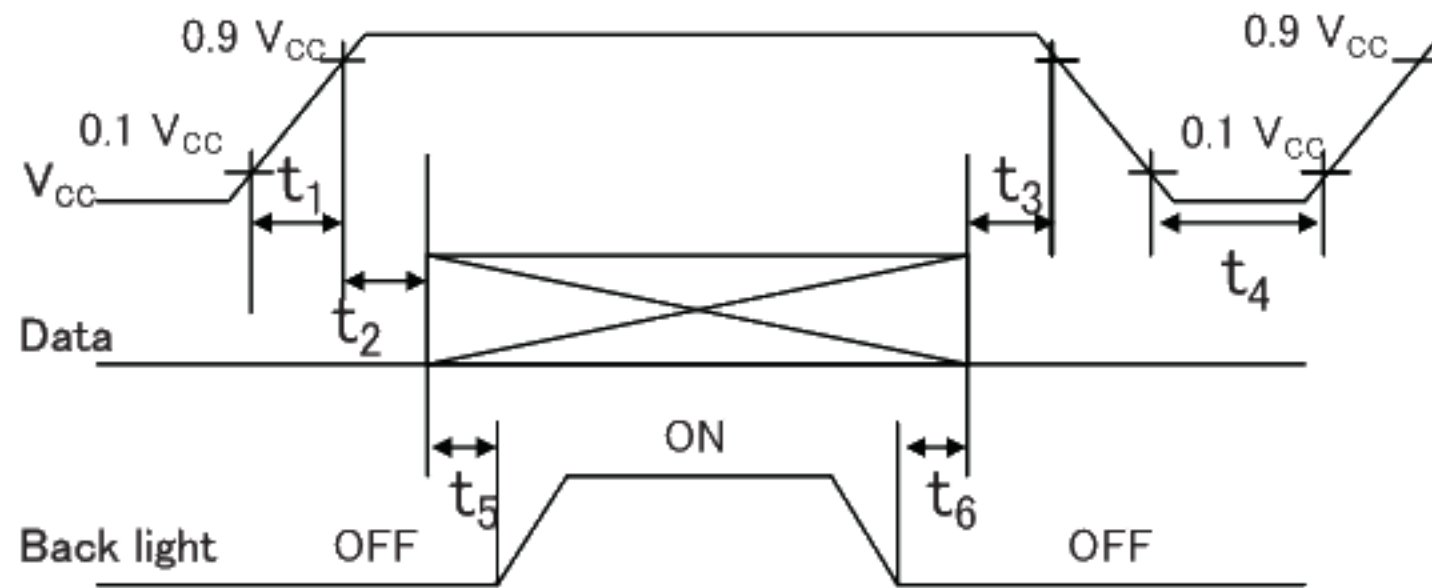

$$20\mu\text{s} < t_1 \leq 10\text{ms}$$

$$0\text{s} < t_2 \leq 20\text{ms}$$

$$0\text{s} < t_3 \leq 1\text{s}$$

$$1\text{s} \leq t_4$$

$$300\text{ms} \leq t_5$$

$$300\text{ms} \leq t_6$$

$V_{CC}$ -dip conditions

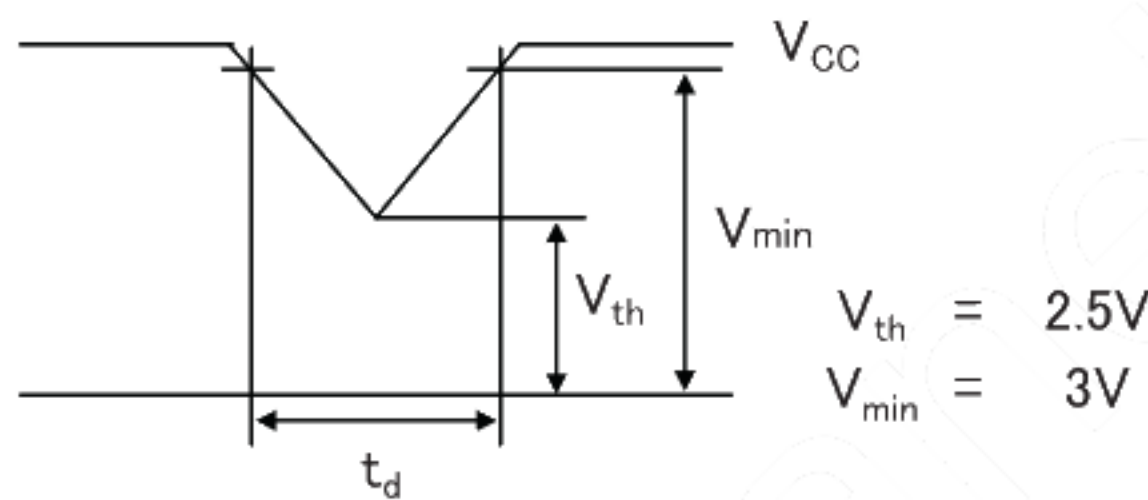

$$V_{th} < V_{CC} \leq V_{min}$$

$$t_d \leq 10\text{ms}$$

$$V_{CC} < V_{th}$$

$V_{CC}$ -dip conditions should also follow the On-off conditions for supply voltage

- The relation between the data input and the backlight lighting will recommend the above-mentioned input sequence. When the backlight is turned on before the panel operates, there is a possibility of abnormally displaying. The liquid crystal module is not damaged.

【Note2】 Current dissipation

Typical current situation : 64-gray-bar pattern

$V_{CC}=+3.3\text{V}$ ,  $f_{ck} = 25.175\text{MHz}$ ,  $T_a=25^\circ\text{C}$

Refer to Chapter 8 for RGB each step.

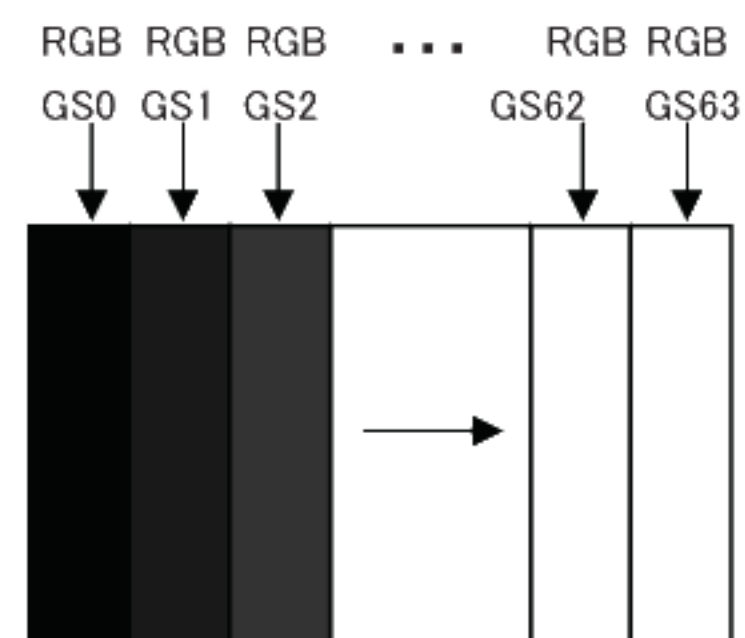

【Note3】 R0-5、G0-5、B0-5、CK、Hsyn、Vsync、ENAB、SCAN



6-2. LED backlight

Ta=+25°C

| Parameter                       | Symbol             | Min.                | Typ.               | Max.    | Unit              | Remark                  |         |
|---------------------------------|--------------------|---------------------|--------------------|---------|-------------------|-------------------------|---------|
| Supply voltage                  | V <sub>DD</sub>    | 10.8                | 12.0               | 13.2    | V                 | 【Note1】                 |         |
| Current dissipation             | I <sub>DD1</sub>   | -                   | 400                | 500     | mA                | 【Note2】                 |         |
|                                 | I <sub>DD2</sub>   | -                   | -                  | 10.0    | μA                |                         |         |
| Permissive input ripple voltage | V <sub>RP_BL</sub> | -                   | -                  | 200.0   | mV <sub>P-P</sub> | V <sub>DD</sub> =+12.0V |         |
| XSTABY                          | High voltage       | V <sub>IH_BL1</sub> | 9.0                | -       | V <sub>DD</sub>   | V                       | 【Note3】 |
|                                 | Low voltage        | V <sub>IL_BL1</sub> | -                  | -       | 0.4               | V                       | 【Note3】 |
| VBR                             | High voltage       | V <sub>IH_BL2</sub> | 9.0                | -       | V <sub>DD</sub>   | V                       | 【Note4】 |
|                                 | Low voltage        | V <sub>IL_BL2</sub> | -                  | -       | 0.4               | V                       | 【Note4】 |
| PWM frequency                   | f <sub>PWM</sub>   | 200.0               | -                  | 1,000.0 | Hz                | 【Note4,5】               |         |
| PWM duty                        | D <sub>PWM</sub>   | 10.0                | -                  | 100.0   | %                 | 【Note4,5】               |         |
| Life time                       | L                  | -                   | 50,000<br>(Module) | -       | h                 | 【Reference】<br>【Note6】  |         |

【Note1】 On-off conditions for supply voltage

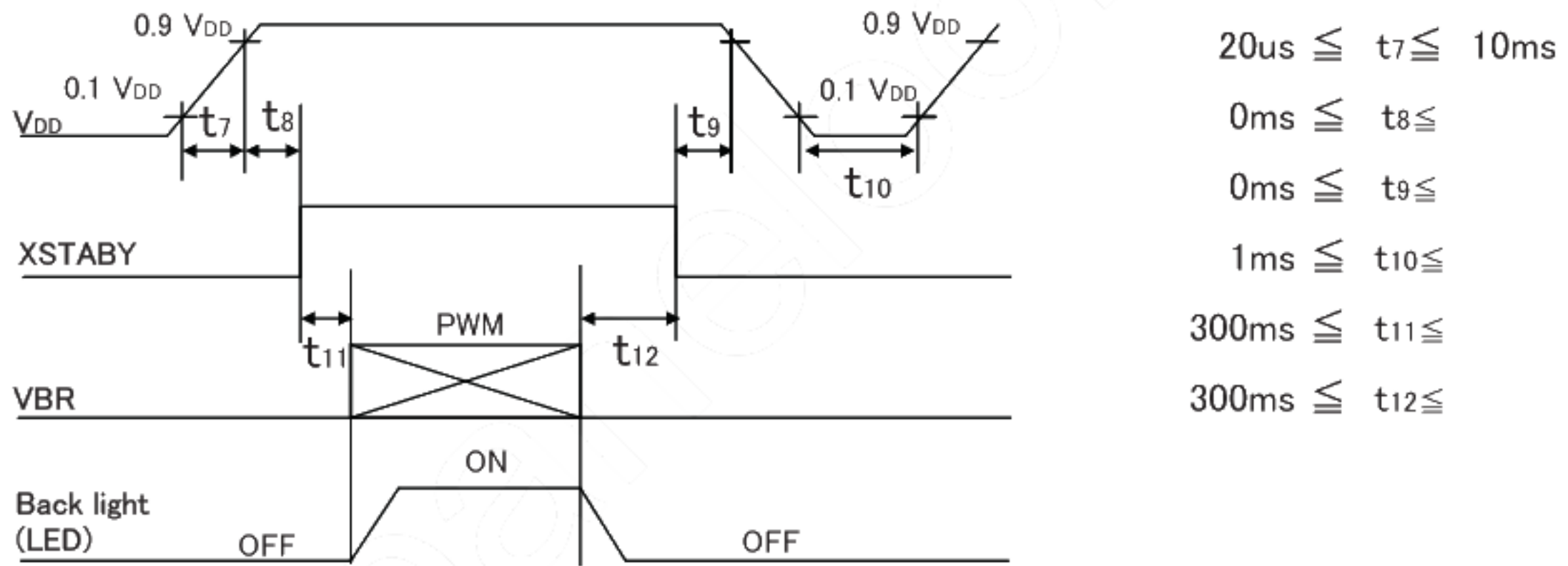

【Note2】 Current dissipation

Typ. value: V<sub>DD</sub>= +12V, Duty=100%  
 Max. value: V<sub>DD</sub>= +10.8V, Duty=100%

【Note3】 XSTABY is connected by the pull-down resistor of about 2.8kΩ.

【Note4】 VBR is connected by the pull-down resistor of about 9.6kΩ.

【Note5】 PWM

$$f_{PWM} = 1/t_{14} \quad D_{PWM} = t_{13}/t_{14}$$

Duty 0% : Min. Luminance

Duty 100% : Max. Luminance

Luminance changes in proportion to the duty ratio. ( $t_{13} \geq 100 \mu s$ )

When the frequency slows, the display fineness might decrease.

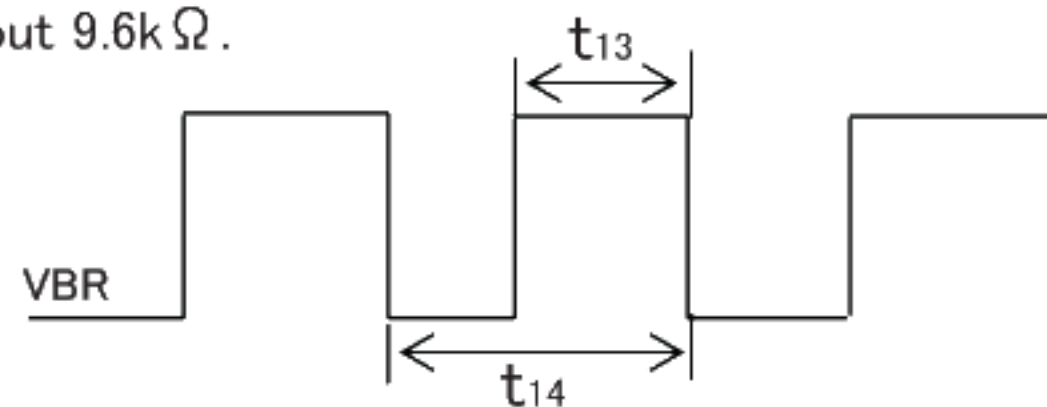

【\*6】 Luminance becomes 50% of an initial value. (Ta=25°C, PWM=100%)

## 7. Timing characteristics of input signals

### 7-1. Timing characteristics

| Parameter                       |                                      | Symbol | Min.   | Typ.  | Max.   | Unit    | Remark  |
|---------------------------------|--------------------------------------|--------|--------|-------|--------|---------|---------|
| Clock                           | Frequency                            | 1/Tc   | 23.0   | 25.18 | 28.3   | MHz     |         |
|                                 | High time                            | TCH    | 10     | —     | —      | ns      |         |
|                                 | Low time                             | TCL    | 10     | —     | —      | ns      |         |
|                                 | Duty ratio                           | TH/TC  | 40     | 50    | 60     | %       |         |
| Data                            | Setup time                           | TDS    | 5      | —     | —      | ns      |         |
|                                 | Hold time                            | TDH    | 10     | —     | —      | ns      |         |
| Horizontal sync. signal (Hsync) | Setup time                           | THC    | 5      | —     | —      | ns      |         |
|                                 | Cycle                                | TH     | 750    | 800   | 900    | clock   |         |
|                                 |                                      |        | 26.50  | 31.78 | 39.0   | $\mu s$ |         |
|                                 | Pulse width                          | THP    | 2      | 96    | 200    | clock   |         |
|                                 | Data start position                  | THS    | 104    | 104   | 104    | clock   | 【Note2】 |
| Vertical sync. signal (Vsync)   | Setup time                           | TVH    | 0      | —     | TH-THP | clock   |         |
|                                 | Cycle                                | TV     | 515.00 | 525   | 560.0  | line    |         |
|                                 | Frequency                            | 1/TV   | 56     | 60    | 70     | Hz      | 【Note1】 |
|                                 | Pulse width                          | TVP    | 1      | 2     | 32     | line    |         |
|                                 | Data start position                  | TVS    | 34     | 34    | 34     | line    |         |
| Enable signal                   | Setup time                           | TEC    | 5      | —     | —      | ns      |         |
|                                 | Pulse width                          | TEP    | 640    | 640   | 640    | clock   |         |
|                                 | Hsync-Enable signal phase difference | THE    | 44     | —     | TH-664 | clock   |         |
| display period                  | Horizontal                           | THD    | 640    | 640   | 640    | clock   |         |
|                                 | Vertical                             | TVD    | 480    | 480   | 480    | line    |         |

【Note1】 In case of lower frequency, the deterioration of display quality, flicker etc., may be occurred.

【Note2】 When ENAB is fixed "Low", the display starts from THS(104clock) as shown in Fig.4-3.

Be careful that the module does not work when ENAB is fixed "High".

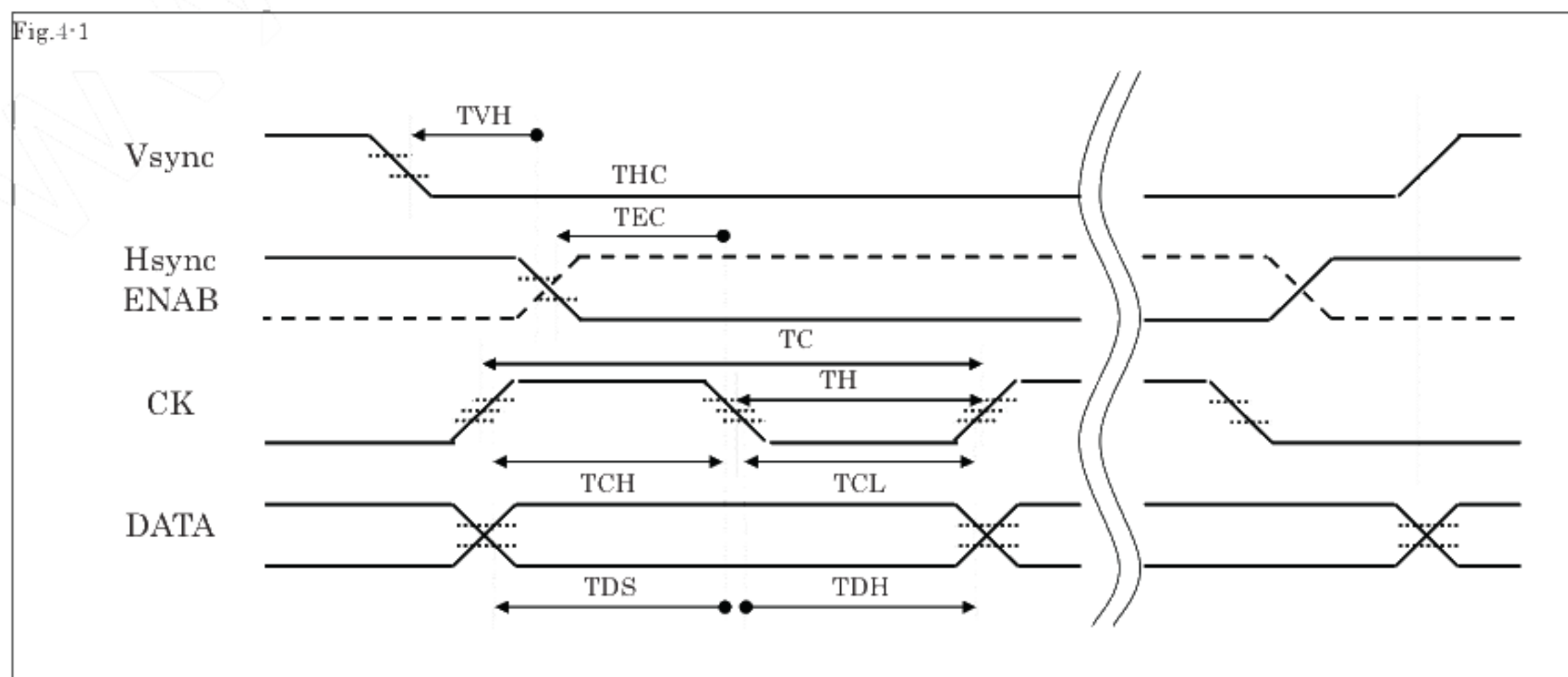

Fig.4-2

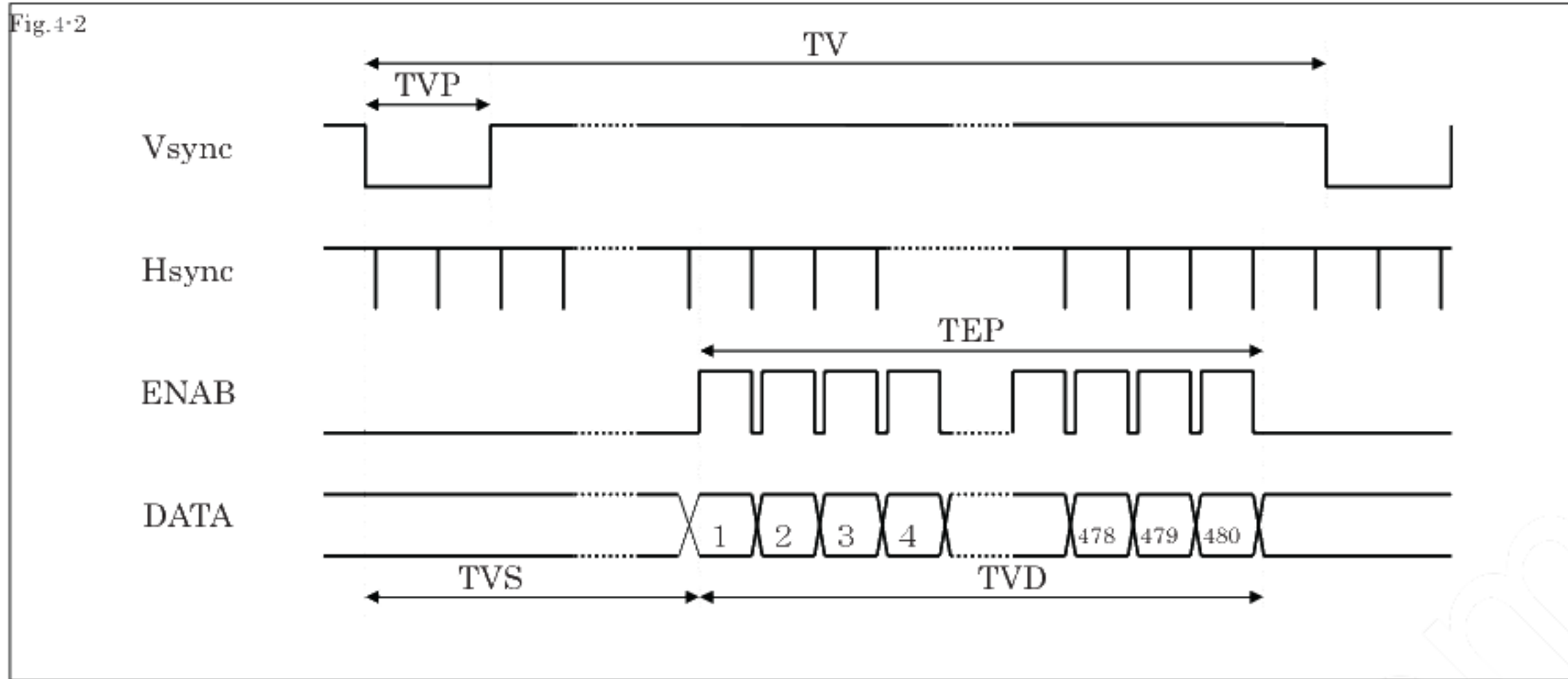
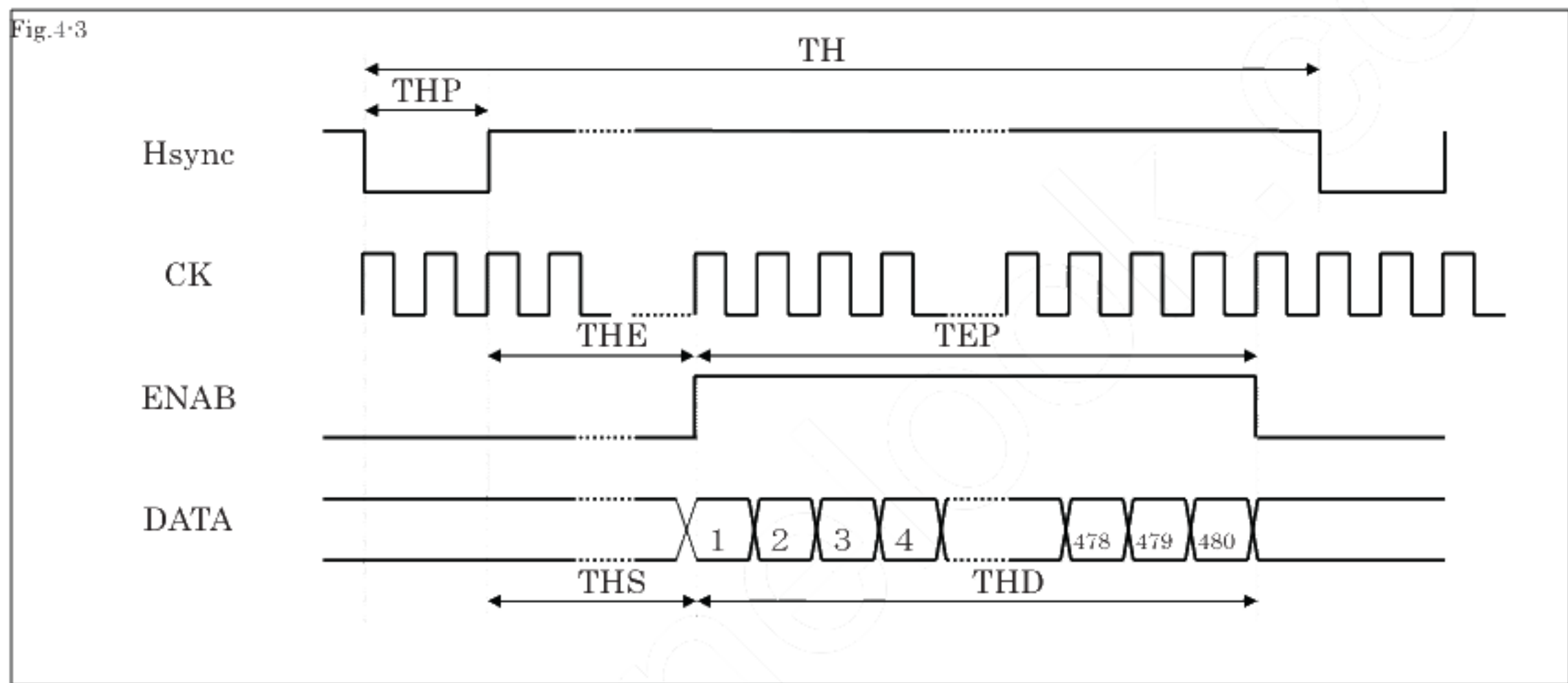
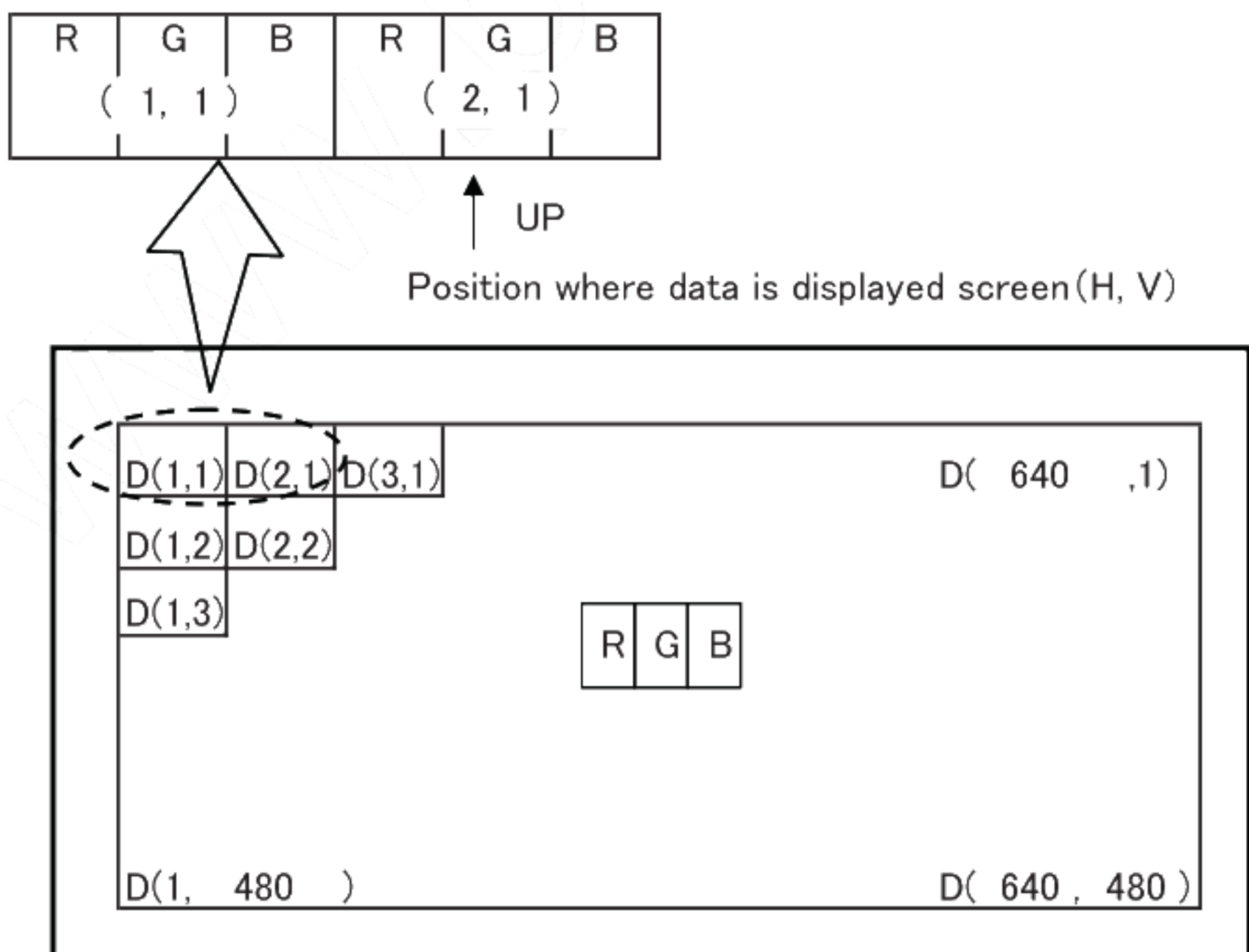

Fig.4-3



7-2. Input Data Signals and Display Position on the screen



## 8. Input Signals, Basic Display Colors and Gray Scale of Each Color

### 8-1. 6 bit input

|                     | Colors & Gray scale | Data signal |    |    |    |    |    |    |    |    |    |    |    |    |    |    |    |    |    |    |
|---------------------|---------------------|-------------|----|----|----|----|----|----|----|----|----|----|----|----|----|----|----|----|----|----|
|                     |                     | GrayScale   | R0 | R1 | R2 | R3 | R4 | R5 | G0 | G1 | G2 | G3 | G4 | G5 | B0 | B1 | B2 | B3 | B4 | B5 |
| Basic Color         | Black               | —           | 0  | 0  | 0  | 0  | 0  | 0  | 0  | 0  | 0  | 0  | 0  | 0  | 0  | 0  | 0  | 0  | 0  | 0  |
|                     | Blue                | —           | 0  | 0  | 0  | 0  | 0  | 0  | 0  | 0  | 0  | 0  | 0  | 0  | 1  | 1  | 1  | 1  | 1  | 1  |
|                     | Green               | —           | 0  | 0  | 0  | 0  | 0  | 0  | 1  | 1  | 1  | 1  | 1  | 1  | 0  | 0  | 0  | 0  | 0  | 0  |
|                     | Cyan                | —           | 0  | 0  | 0  | 0  | 0  | 0  | 1  | 1  | 1  | 1  | 1  | 1  | 1  | 1  | 1  | 1  | 1  | 1  |
|                     | Red                 | —           | 1  | 1  | 1  | 1  | 1  | 1  | 0  | 0  | 0  | 0  | 0  | 0  | 0  | 0  | 0  | 0  | 0  | 0  |
|                     | Magenta             | —           | 1  | 1  | 1  | 1  | 1  | 1  | 0  | 0  | 0  | 0  | 0  | 0  | 1  | 1  | 1  | 1  | 1  | 1  |
|                     | Yellow              | —           | 1  | 1  | 1  | 1  | 1  | 1  | 1  | 1  | 1  | 1  | 1  | 1  | 0  | 0  | 0  | 0  | 0  | 0  |
|                     | White               | —           | 1  | 1  | 1  | 1  | 1  | 1  | 1  | 1  | 1  | 1  | 1  | 1  | 1  | 1  | 1  | 1  | 1  | 1  |
| Gray Scale of Red   | Black               | GS0         | 0  | 0  | 0  | 0  | 0  | 0  | 0  | 0  | 0  | 0  | 0  | 0  | 0  | 0  | 0  | 0  | 0  | 0  |
|                     | ↑                   | GS1         | 1  | 0  | 0  | 0  | 0  | 0  | 0  | 0  | 0  | 0  | 0  | 0  | 0  | 0  | 0  | 0  | 0  | 0  |
|                     | Darker              | GS2         | 0  | 1  | 0  | 0  | 0  | 0  | 0  | 0  | 0  | 0  | 0  | 0  | 0  | 0  | 0  | 0  | 0  | 0  |
|                     | ↑                   | ↓           | ↓  |    |    |    |    | ↓  |    |    |    |    | ↓  |    |    |    |    |    |    |    |
|                     | ↓                   | ↓           | ↓  |    |    |    |    | ↓  |    |    |    |    | ↓  |    |    |    |    |    |    |    |
|                     | Brighter            | GS61        | 1  | 0  | 1  | 1  | 1  | 1  | 0  | 0  | 0  | 0  | 0  | 0  | 0  | 0  | 0  | 0  | 0  | 0  |
|                     | ↓                   | GS62        | 0  | 1  | 1  | 1  | 1  | 1  | 0  | 0  | 0  | 0  | 0  | 0  | 0  | 0  | 0  | 0  | 0  | 0  |
|                     | Red                 | GS63        | 1  | 1  | 1  | 1  | 1  | 1  | 0  | 0  | 0  | 0  | 0  | 0  | 0  | 0  | 0  | 0  | 0  | 0  |
| Gray Scale of Green | Black               | GS0         | 0  | 0  | 0  | 0  | 0  | 0  | 0  | 0  | 0  | 0  | 0  | 0  | 0  | 0  | 0  | 0  | 0  | 0  |
|                     | ↑                   | GS1         | 0  | 0  | 0  | 0  | 0  | 0  | 1  | 0  | 0  | 0  | 0  | 0  | 0  | 0  | 0  | 0  | 0  | 0  |
|                     | Darker              | GS2         | 0  | 0  | 0  | 0  | 0  | 0  | 0  | 1  | 0  | 0  | 0  | 0  | 0  | 0  | 0  | 0  | 0  | 0  |
|                     | ↑                   | ↓           | ↓  |    |    |    |    | ↓  |    |    |    |    | ↓  |    |    |    |    |    |    |    |
|                     | ↓                   | ↓           | ↓  |    |    |    |    | ↓  |    |    |    |    | ↓  |    |    |    |    |    |    |    |
|                     | Brighter            | GS61        | 0  | 0  | 0  | 0  | 0  | 0  | 1  | 0  | 1  | 1  | 1  | 1  | 0  | 0  | 0  | 0  | 0  | 0  |
|                     | ↓                   | GS62        | 0  | 0  | 0  | 0  | 0  | 0  | 0  | 1  | 1  | 1  | 1  | 1  | 0  | 0  | 0  | 0  | 0  | 0  |
|                     | Green               | GS63        | 0  | 0  | 0  | 0  | 0  | 0  | 1  | 1  | 1  | 1  | 1  | 1  | 0  | 0  | 0  | 0  | 0  | 0  |
| Gray Scale of Blue  | Black               | GS0         | 0  | 0  | 0  | 0  | 0  | 0  | 0  | 0  | 0  | 0  | 0  | 0  | 0  | 0  | 0  | 0  | 0  | 0  |
|                     | ↑                   | GS1         | 0  | 0  | 0  | 0  | 0  | 0  | 0  | 0  | 0  | 0  | 0  | 0  | 1  | 0  | 0  | 0  | 0  | 0  |
|                     | Darker              | GS2         | 0  | 0  | 0  | 0  | 0  | 0  | 0  | 0  | 0  | 0  | 0  | 0  | 0  | 1  | 0  | 0  | 0  | 0  |
|                     | ↑                   | ↓           | ↓  |    |    |    |    | ↓  |    |    |    |    | ↓  |    |    |    |    |    |    |    |
|                     | ↓                   | ↓           | ↓  |    |    |    |    | ↓  |    |    |    |    | ↓  |    |    |    |    |    |    |    |
|                     | Brighter            | GS61        | 0  | 0  | 0  | 0  | 0  | 0  | 0  | 0  | 0  | 0  | 0  | 0  | 1  | 0  | 1  | 1  | 1  | 1  |
|                     | ↓                   | GS62        | 0  | 0  | 0  | 0  | 0  | 0  | 0  | 0  | 0  | 0  | 0  | 0  | 0  | 1  | 1  | 1  | 1  | 1  |
|                     | Blue                | GS63        | 0  | 0  | 0  | 0  | 0  | 0  | 0  | 0  | 0  | 0  | 0  | 0  | 1  | 1  | 1  | 1  | 1  | 1  |

0 : Low level voltage, 1 : High level voltage

Each basic color can be displayed in 64 gray scales from 6 bit data signals. According to the combination of total 18 bit data signals, the 262,144-color display can be achieved on the screen.

## 9. Optical Characteristics

Ta=+25°C, Vcc=+3.3V

| Parameter             |             | Symbol                 | Condition          | Min.  | Typ.  | Max.  | Unit | Remark      |                   |         |
|-----------------------|-------------|------------------------|--------------------|-------|-------|-------|------|-------------|-------------------|---------|
| Viewing angle range   | Horizontal  | $\theta 21, \theta 22$ | CR>10              | 70    | 80    | -     | Deg. | 【Note1,2,4】 |                   |         |
|                       | Vertical    | $\theta 11$            |                    | 45    | 65    | -     | Deg. |             |                   |         |
|                       |             | $\theta 12$            |                    | 70    | 80    | -     | Deg. |             |                   |         |
| Contrast ratio        |             | CR                     | optimized angle    | 450   | 800   | -     |      | 【Note2,4】   |                   |         |
| Response Time         | White Black | $\tau r + \tau d$      |                    | -     | 35    | -     | ms   | 【Note3,4】   |                   |         |
| Chromaticity of White |             | Wx                     | $\theta = 0^\circ$ | 0.350 | 0.300 | 0.250 |      | 【Note4】     |                   |         |
|                       |             | Wy                     |                    | 0.370 | 0.320 | 0.270 |      |             |                   |         |
| Chromaticity of Red   |             | Rx                     |                    | -     | 0.560 | -     |      |             |                   |         |
|                       |             | Ry                     |                    | -     | 0.325 | -     |      |             |                   |         |
| Chromaticity of Green |             | Gx                     |                    | -     | 0.335 | -     |      |             |                   |         |
|                       |             | Gy                     |                    | -     | 0.595 | -     |      |             |                   |         |
| Chromaticity of Blue  |             | Bx                     |                    | -     | 0.155 | -     |      |             |                   |         |
|                       |             | By                     |                    | -     | 0.120 | -     |      |             |                   |         |
| Luminance of white    |             | $Y_{L1}$               |                    |       | 360   | 450   | -    |             | cd/m <sup>2</sup> | 【Note4】 |
| White Uniformity      |             |                        |                    |       | -     | -     | 1.33 |             |                   | 【Note5】 |

※The measurement shall be executed 30 minutes after lighting at rating.

The optical characteristics shall be measured in a dark room or equivalent state with the method shown in Fig.2 below.

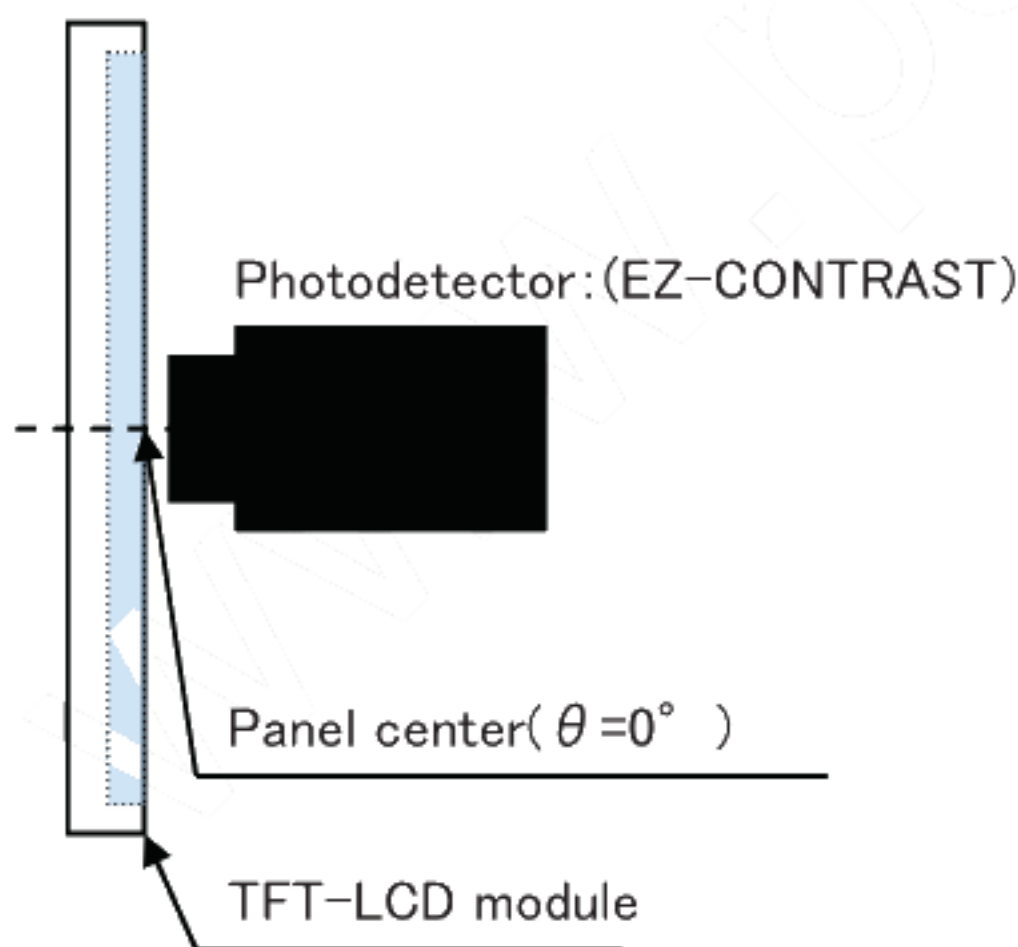

fig.2-1 Measuring method of Viewing angle range.

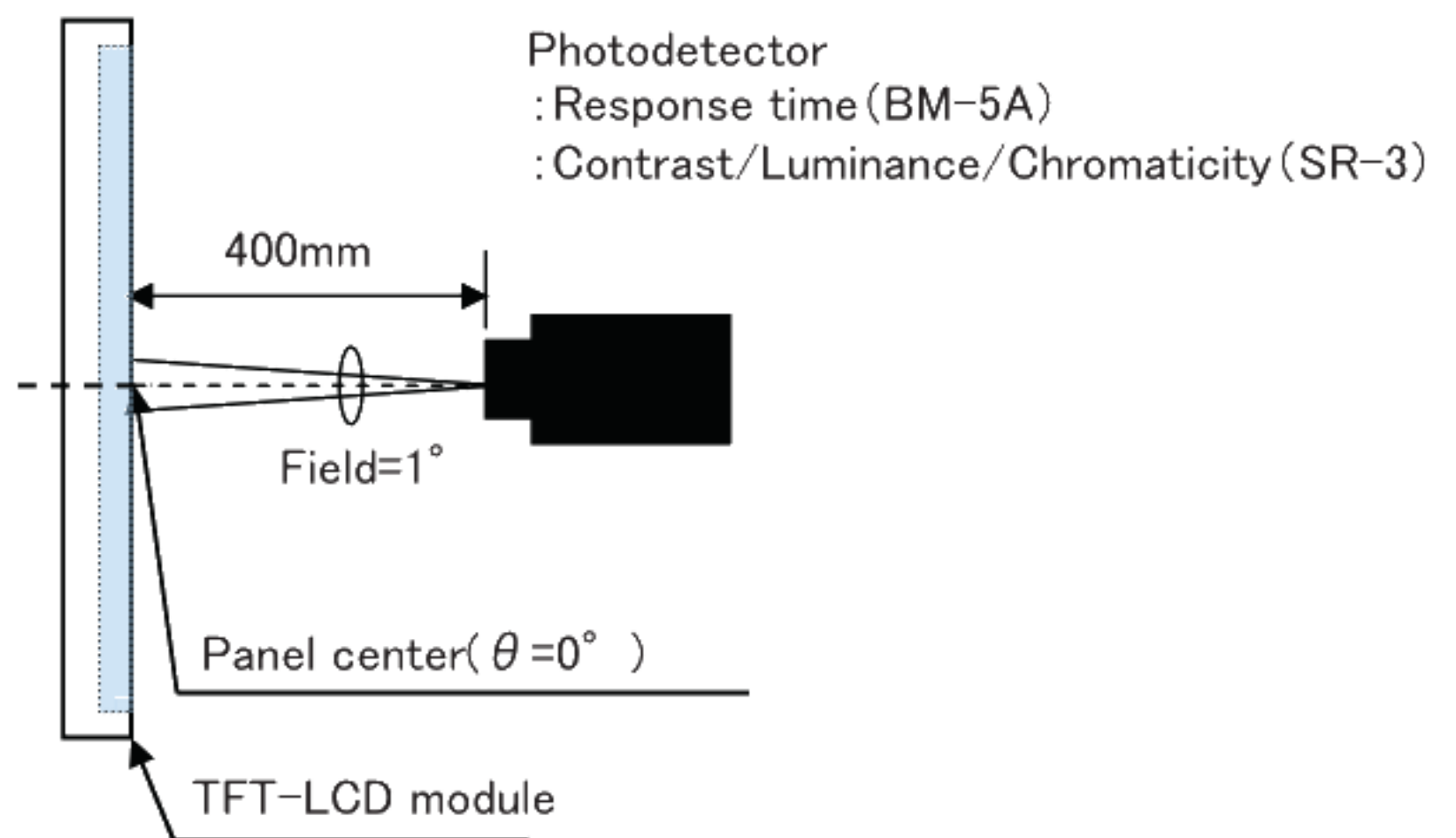
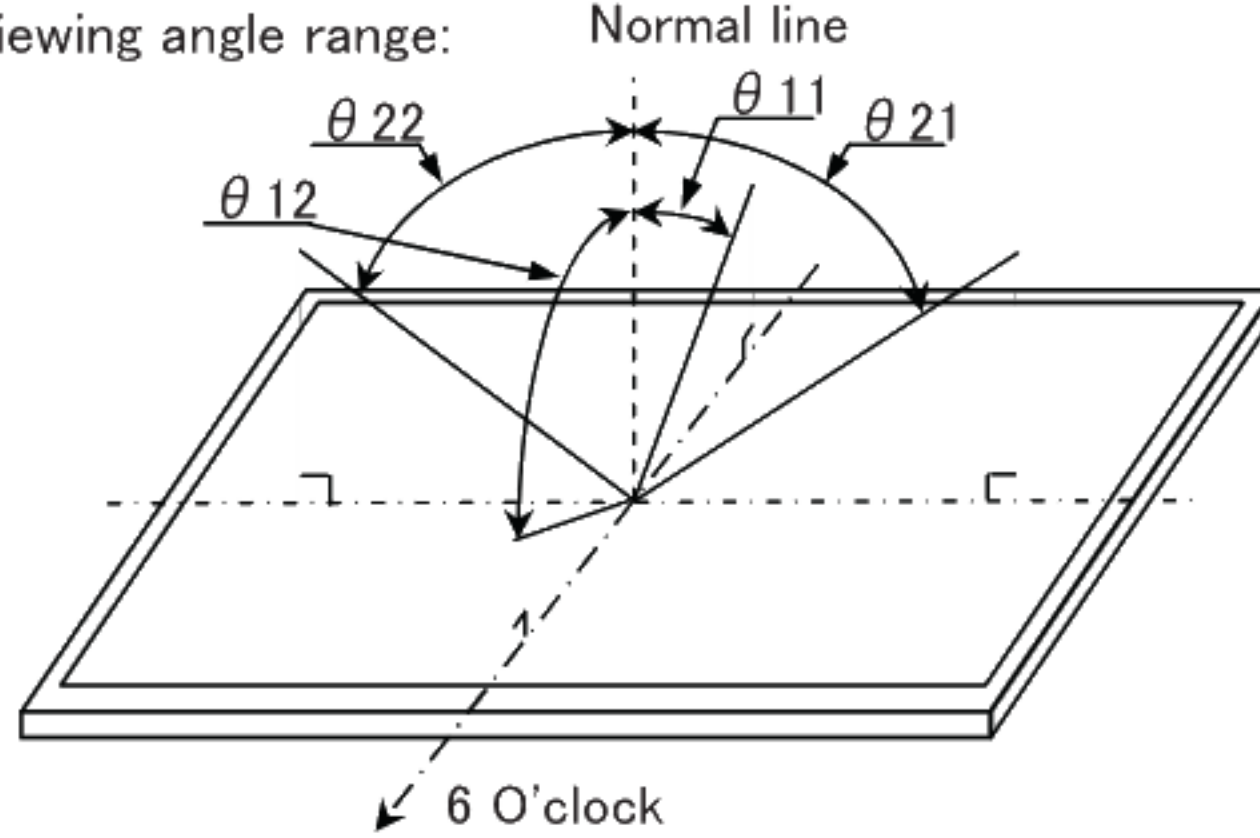

fig.2-2 Measuring method of contrast, luminance, response time, and Chromaticity.

Fig.2 Optical characteristics measurement method

【Note1】Definitions of viewing angle range:



【Note2】Definition of contrast ratio:

The contrast ratio is defined as the following. 
$$\text{Contrast (CR)} = \frac{\text{Luminance with all pixels white}}{\text{Luminance with all pixels black}}$$

【Note3】Definition of response time:

The response time is defined as the following figure and shall be measured by switching the input signal for "black" and "white".

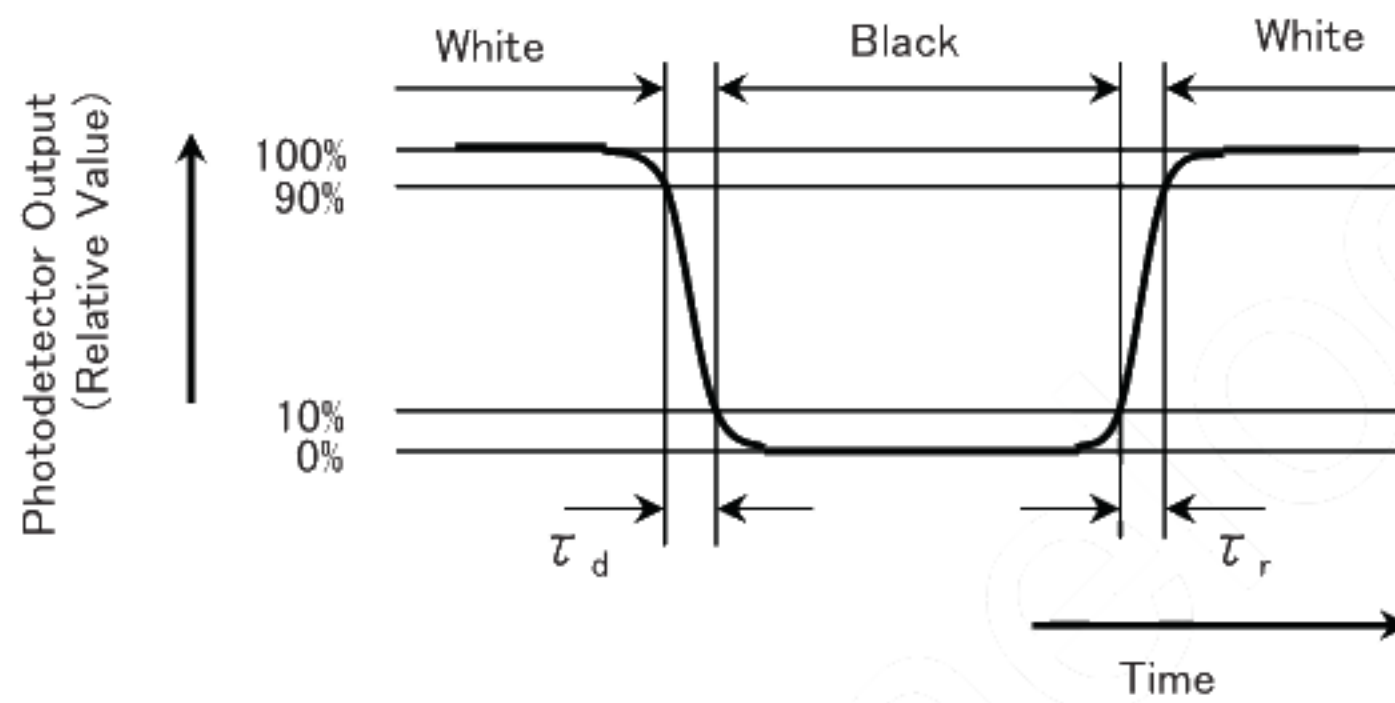

【Note4】This shall be measured at center of the screen.

【Note5】Definition of white uniformity:

White uniformity is defined as the following with five measurements.

(①~⑤)

$$\delta_w = \frac{\text{Maximum luminance of 5 points(①~⑤)}}{\text{Maximum luminance of 5 points(①~⑤)}}$$

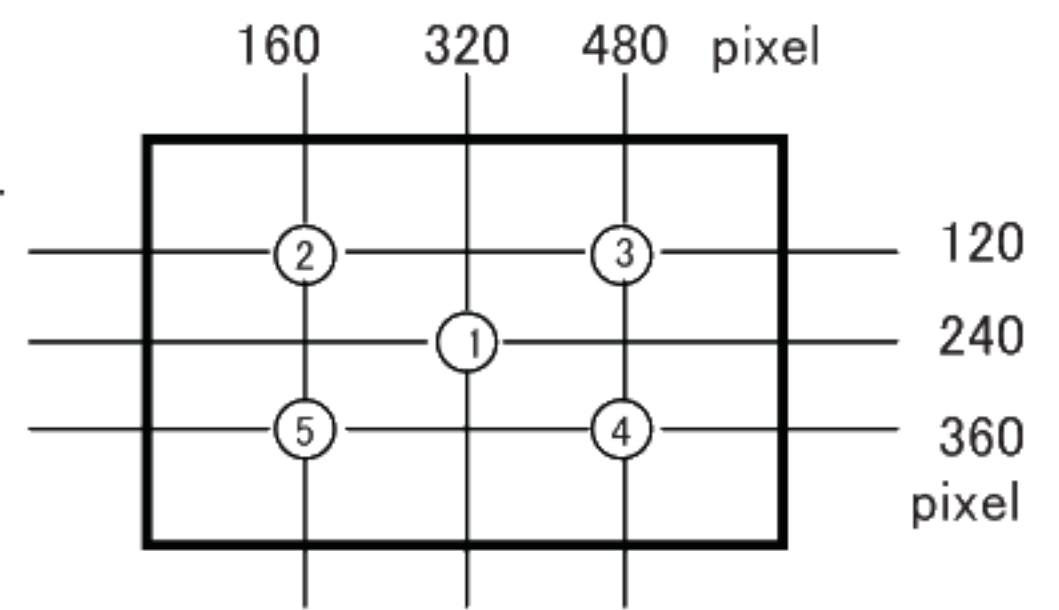

## 10. Handling Precautions

- a ) Be sure to turn off the power supply when inserting or disconnecting the cable.
- b ) Since the front polarizer is easily damaged, pay attention not to scratch it.
- c ) Wipe off water drop immediately. Long contact with water may cause discoloration or spots.
- d ) When the panel surface is soiled, wipe it with absorbent cotton or other soft cloth.
- e ) Since the panel is made of glass, it may break or crack if dropped or bumped on hard surface.  
Handle with care.
- f ) Since CMOS LSI is used in this module, take care of static electricity and injure the human earth when handling. Observe all other precautionary requirements in handling components.
- g ) Since there is a circuit board in the module back, stress is not added at the time of a design assembly. Please make it like. If stress is added, there is a possibility that circuit parts may be damaged.
- h ) It causes an irregular display and the defective indication, etc., when always put constant pressure on the back of the module.  
Please do not make the structure to press the back of the module.
- i ) Do not expose the LCD panel to direct sunlight. Lightproof shade etc. should be attached when LCD panel is used under such environment.
- j ) Connect GND to stabilize against EMI and external noise.
- k ) When handling LCD modules and assembling them into cabinets, please avoid that long-terms storage in the environment of oxidization or deoxidization gas and the use of such materials as reagent, solvent, adhesive, resin, etc. which generate these gasses, may cause corrosion and discoloration of the modules. Do not use the LCD module under such environment.
- l ) Liquid crystal contained in the panel may leak if the LCD is broken. Rinse it as soon as possible if it gets inside your eye or mouth by mistake.
- m ) Be careful when using it for long time with fixed pattern display as it may cause accidental image.
- n ) Adjusting volume have been set optimally before shipment, so do not change any adjusted value. If adjusted value is changed, the specification may not be satisfied.
- o ) If a minute particle enters in the module and adheres to an optical material, it may cause display non-uniformity issue, etc. Therefore, fine-pitch filters have to be installed to cooling and inhalation hole if you intend to install a fan.
- p ) An abnormal display by changing in quality of the polarizing plate might occur regardless of contact or no contact to the polarizing plate, because of epoxy resin (amine system curing agent) that comes out from the material and the packaging material used for the set side, the silicon adhesive (dealcoholization system and oxime system), and the tray blowing agents (azo-compound), etc.  
Please confirm adaptability with your employed material.
- q ) The polarizer surface on the panel is treated with Anti-Glare for low reflection. In case of attaching protective board over the LCD, be careful about the optical interface fringe etc. which degrades display quality.
- r ) Never take to pieces the module , because it will cause failure.  
Please do not peel off the Black tape pasted to the product.
- s ) Be sure to design the cabinet so that the module can be installed without any extra stress such as warp or twist.

## 11. Packing form

- a) Piling number of cartons : MAX. 6
- b) Package quantity in one carton: 20pcs
- c) Carton size(TYP): 451mm(W) × 440mm(D) × 313mm(H)
- d) Total mass of one carton filled with full modules(20pcs): 13.5kg

Packing form is shown in Fig 3.

## 12. Reliability test items

| No. | Test item                                       | Conditions   | Remark  |
|-----|---|--|---------|
| 1   | High temperature storage test                   | Ambient temperature 80°C 240H  | 【Note1】 |
| 2   | Low temperature storage test                    | Ambient temperature -30°C 240H   | 【Note1】 |
| 3   | High temperature & high humidity operation test | Ambient temperature 40°C、Humidity 95% RH 240H<br>(No condensation.)  | 【Note1】 |
| 4   | High temperature operation test                 | Panel surface(Active Area) 80°C 240H   | 【Note1】 |
| 5   | Low temperature operation test                  | Ambient temperature -30°C 240H   | 【Note1】 |
| 6   | Vibration test                                  | < Sin wave ><br>Frequency : 10~57Hz / Vibration width (one side) : 0.076mm<br>: 57~500Hz / Gravity : 9.8m/s <sup>2</sup><br>Sweep time : 11minutes<br>Test period : 3H(X, Y, Z direction 1H) | 【Note1】 |
| 7   | Shock test                                      | Max. gravity : 490m/s <sup>2</sup> Pulse width : 11ms<br>Direction : ±X, ±Y, ±Z Test period : 1time / 1direction   | 【Note1】 |

【Note1】 Under the display quality test conditions with normal operation state, these shall be no change which may affect practical display function. (normal operation state: Temperature: 15~35°C, Humidity: 45~75%, Atmospheric pressure: 86~106kpa)



### 13. Others

#### 13-1. Lot No Label:

##### A) Module serial label

The label that displays SHARP·Model No.( LQ104V1DG81)·Lot No. is stuck on the back of the module.

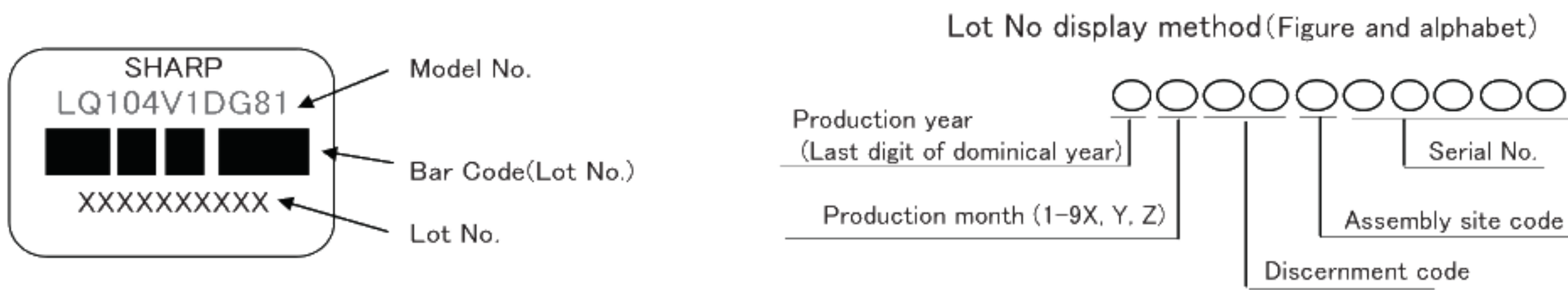

##### B) Backlight serial label

The label that displays the model No. and lot No. for the backlight is stuck on the back of the module.

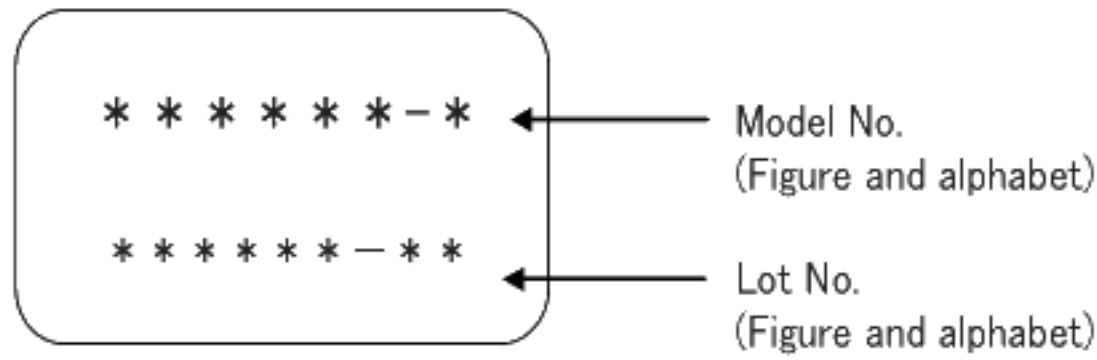

#### 13-2. Packing box Label:

The label that displays ①Model number( LQ104V1DG81) ②Lot number ③Quantity of module is stuck on the packing box. Moreover, the display of bar code also applies to this.

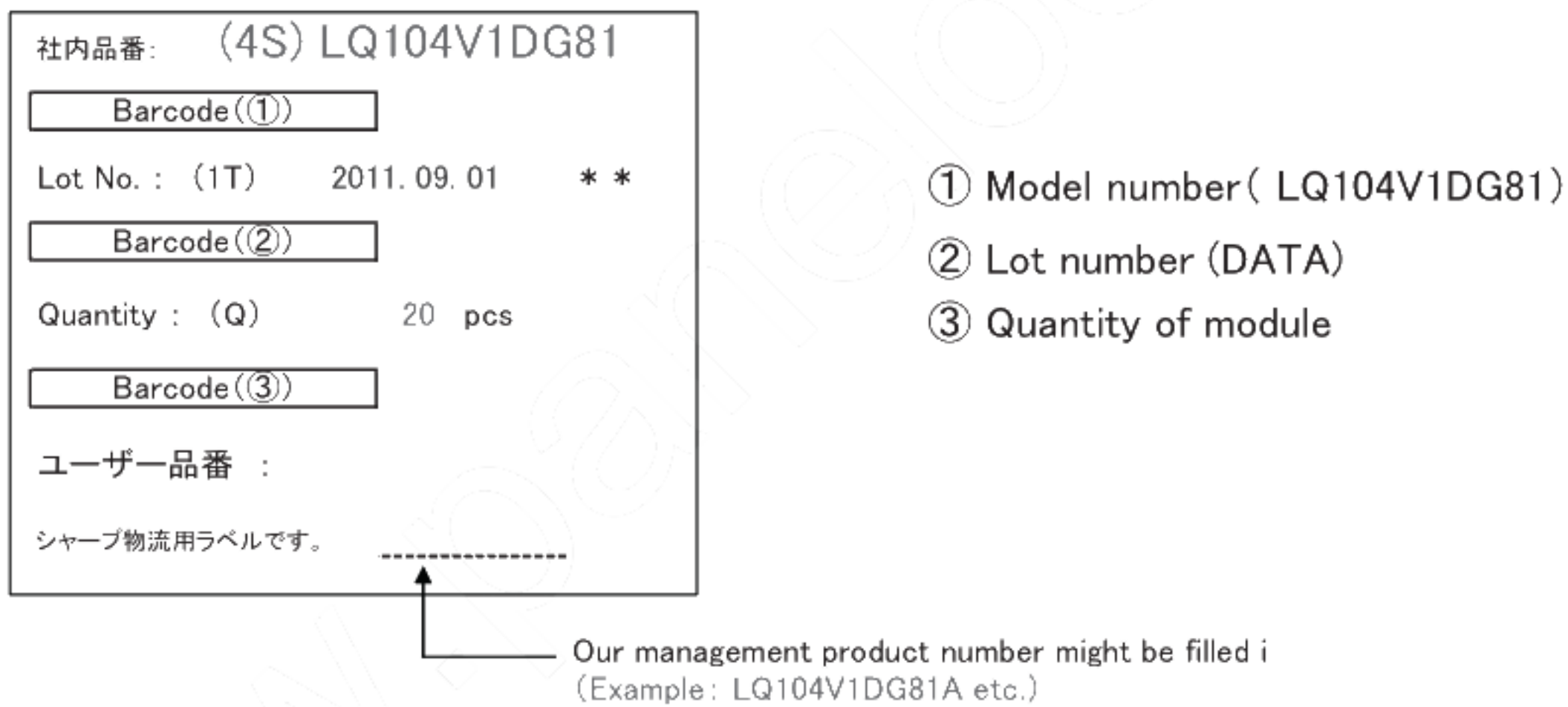

A right picture is written to the packing box of module for the RoHS restriction.

※ R.C.(RoHs Compliance)means these parts have corresponded with the RoHs directive.

**R.C.**

This module corresponds from the first sample to RoHS Directive.

The production country of the figure below is written in the wrapping box.

MADE IN JAPAN OR MADE IN CHINA

#### 13-3. The ozone-depleting substances is not used.

#### 13-4. If any problem occurs in relation to the description of this specification , it shall be resolved through discussion with spirit of cooperation.

## 14. Storage conditions

Environmental condition range of storage temperature and humidity

Temperature 0 to 40 degrees Celsius

Relative humidity 95% and below

【Note】Please refer below as a mean value of the environmental conditions.

Summer time temperature 20 to 35 degrees Celsius humidity , 85% and below

Winter time temperature 5 to 15 degrees Celsius humidity , 85% and below

Please maintain within 240 hours of accumulated length of storage time, with conditions of 40 degrees Celsius and room humidity of 95%.

Direct sun light

Please keep the product in a dark room or cover the product to protect from direct sun light.

Atmospheric condition

Please refrain from keeping the product with possible corrosive gas or volatile flux.

Prevention of dew

Please store the product carton either on a wooden pallet or a stand / rack to prevent dew.

Do not place directly on the floor. In addition, to obtain moderate ventilation in between the pallet's top and bottom surfaces, pile the cartons up in a single direction and in order.

Please place the product cartons away from the storage wall.

Storage period

Within above mentioned conditions, maximum storage period should be one year.

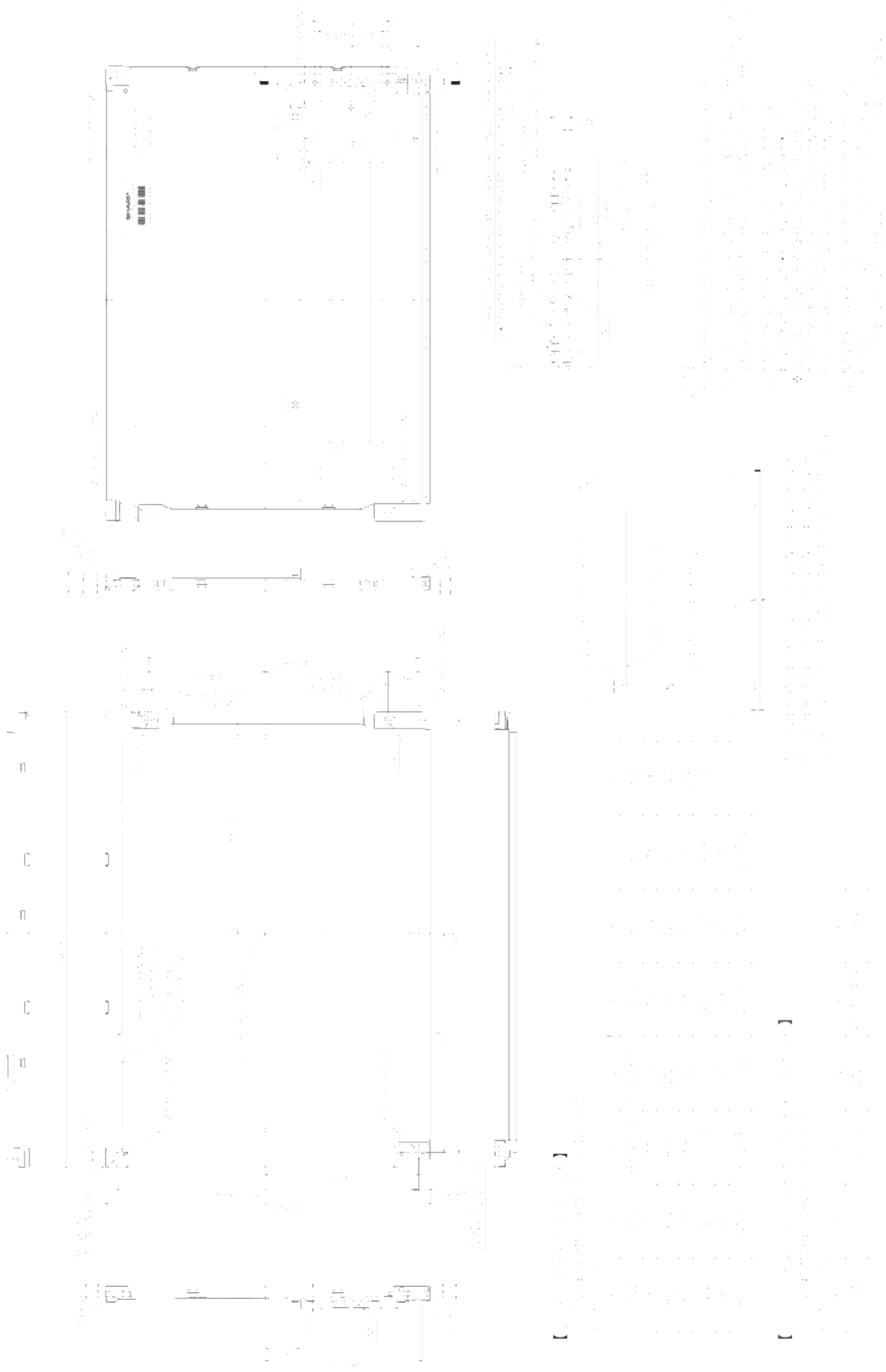

Fig.1 : LQ104V1DG81 OUTLINE DIMENSIONS

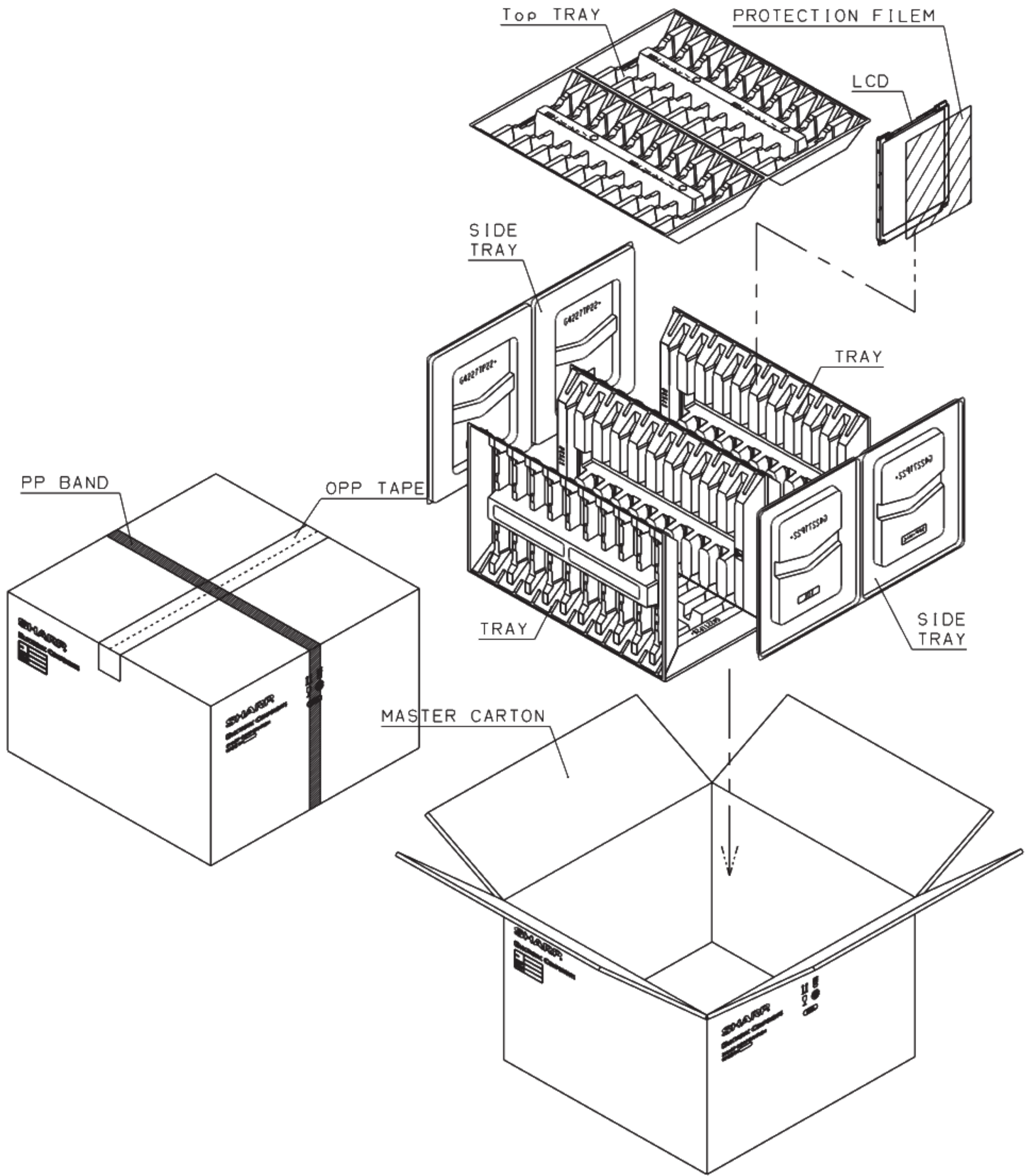

Fig.3 : PACKING FORM