



# Product Specification

G230HAN01.1

AU OPTRONICS CORPORATION

- Preliminary Specification
- Final Specification

<b>Module</b>	23.0" FHD Color TFT-LCD
<b>Model Name</b>	G230HAN01.1

Customer	Date
_____	_____
<b>Approved by</b>	
_____	_____
Customer's sign back page	

Checked & Approved by	Date
<i>Crystal Hsieh</i>	<u>2017.04.10</u>
<b>Prepared by</b>	
<i>Jimmy Tsai</i>	<u>2017.04.10</u>
General Display Business Unit / AU Optronics corporation	



## Record of Revision

Version & Date	Page	Old Description	New Description																																																																																																																																									
V0.1 & 2015/10/06	All	Frist Edition																																																																																																																																										
V0.2 & 2016/04/11	6	<table border="1"> <tr> <td>Luminance Uniformity-</td> <td>[%]</td> <td>11 Points-</td> <td>75-</td> <td>85-</td> </tr> </table>	Luminance Uniformity-	[%]	11 Points-	75-	85-	<table border="1"> <tr> <td>Luminance Uniformity-</td> <td>[%]</td> <td>9 Points-</td> <td>75-</td> <td>80-</td> </tr> </table>	Luminance Uniformity-	[%]	9 Points-	75-	80-																																																																																																																															
Luminance Uniformity-	[%]	11 Points-	75-	85-																																																																																																																																								
Luminance Uniformity-	[%]	9 Points-	75-	80-																																																																																																																																								
	10	Old Block Diagram	Updated Black Diagram																																																																																																																																									
	11	With Temp-Humility drawing	Without Temp-Humility drawing																																																																																																																																									
	13	<table border="1"> <tr> <td>LED Life Time</td> <td></td> <td>30,000</td> <td></td> <td>Hrs</td> <td>4~60 mA Ta= 25°C</td> </tr> </table>	LED Life Time		30,000		Hrs	4~60 mA Ta= 25°C	<table border="1"> <tr> <td>LED Life Time</td> <td></td> <td>30,000</td> <td></td> <td>Hrs</td> <td>4~60 mA Ta= 25°C</td> </tr> </table>	LED Life Time		30,000		Hrs	4~60 mA Ta= 25°C																																																																																																																													
LED Life Time		30,000		Hrs	4~60 mA Ta= 25°C																																																																																																																																							
LED Life Time		30,000		Hrs	4~60 mA Ta= 25°C																																																																																																																																							
	18	<table border="1"> <thead> <tr> <th>Signal</th> <th>Item</th> <th>Symbol</th> <th>Min</th> <th>Typ</th> <th>Max</th> <th>Unit</th> </tr> </thead> <tbody> <tr> <td rowspan="3">Vertical Section</td> <td>Period</td> <td>Tp</td> <td>1090</td> <td>1100</td> <td>1150</td> <td>ns</td> </tr> <tr> <td>Active</td> <td>Tasp</td> <td>1080</td> <td>1080</td> <td>1080</td> <td>ns</td> </tr> <tr> <td>Blanking</td> <td>Tbpb+Tbpl+PWhs</td> <td>10</td> <td>20</td> <td>80</td> <td>ns</td> </tr> <tr> <td rowspan="3">Horizontal Section</td> <td>Period</td> <td>Th</td> <td>1000</td> <td>1085</td> <td>1120</td> <td>ns</td> </tr> <tr> <td>Active</td> <td>TaspH</td> <td>960</td> <td>960</td> <td>960</td> <td>ns</td> </tr> <tr> <td>Blanking</td> <td>TbpbH+TbplH+PWhs</td> <td>40</td> <td>128</td> <td>160</td> <td>ns</td> </tr> <tr> <td rowspan="2">Clock</td> <td>Period</td> <td>Tck</td> <td>11.75</td> <td>13.85</td> <td>15.38</td> <td>ns</td> </tr> <tr> <td>Frequency</td> <td>Freq</td> <td>60</td> <td>72</td> <td>87.5</td> <td>MHz</td> </tr> <tr> <td rowspan="2">Frame Rate</td> <td>Frequency</td> <td>1/Fr</td> <td>30</td> <td>60</td> <td>75</td> <td>Hz</td> </tr> </tbody> </table>	Signal	Item	Symbol	Min	Typ	Max	Unit	Vertical Section	Period	Tp	1090	1100	1150	ns	Active	Tasp	1080	1080	1080	ns	Blanking	Tbpb+Tbpl+PWhs	10	20	80	ns	Horizontal Section	Period	Th	1000	1085	1120	ns	Active	TaspH	960	960	960	ns	Blanking	TbpbH+TbplH+PWhs	40	128	160	ns	Clock	Period	Tck	11.75	13.85	15.38	ns	Frequency	Freq	60	72	87.5	MHz	Frame Rate	Frequency	1/Fr	30	60	75	Hz	<table border="1"> <thead> <tr> <th>Signal</th> <th>Item</th> <th>Symbol</th> <th>Min</th> <th>Typ</th> <th>Max</th> <th>Unit</th> </tr> </thead> <tbody> <tr> <td rowspan="3">Vertical Section</td> <td>Period</td> <td>Tp</td> <td>1090</td> <td>1100</td> <td>1150</td> <td>ns</td> </tr> <tr> <td>Active</td> <td>Tasp</td> <td>1080</td> <td>1080</td> <td>1080</td> <td>ns</td> </tr> <tr> <td>Blanking</td> <td>Tbpb+Tbpl+PWhs</td> <td>10</td> <td>20</td> <td>80</td> <td>ns</td> </tr> <tr> <td rowspan="3">Horizontal Section</td> <td>Period</td> <td>Th</td> <td>1000</td> <td>1088</td> <td>1120</td> <td>ns</td> </tr> <tr> <td>Active</td> <td>TaspH</td> <td>960</td> <td>960</td> <td>960</td> <td>ns</td> </tr> <tr> <td>Blanking</td> <td>TbpbH+TbplH+PWhs</td> <td>40</td> <td>128</td> <td>160</td> <td>ns</td> </tr> <tr> <td rowspan="2">Clock</td> <td>Period</td> <td>Tck</td> <td>11.75</td> <td>13.85</td> <td>15.38</td> <td>ns</td> </tr> <tr> <td>Frequency</td> <td>Freq</td> <td>60</td> <td>72</td> <td>87.5</td> <td>MHz</td> </tr> <tr> <td rowspan="2">Frame Rate</td> <td>Frequency</td> <td>1/Fr</td> <td>30</td> <td>60</td> <td>75</td> <td>Hz</td> </tr> <tr> <td rowspan="2">Horizontal Frequency</td> <td>Frequency</td> <td>1/Fh</td> <td>40</td> <td>60</td> <td>80</td> <td>Hz</td> </tr> </tbody> </table>	Signal	Item	Symbol	Min	Typ	Max	Unit	Vertical Section	Period	Tp	1090	1100	1150	ns	Active	Tasp	1080	1080	1080	ns	Blanking	Tbpb+Tbpl+PWhs	10	20	80	ns	Horizontal Section	Period	Th	1000	1088	1120	ns	Active	TaspH	960	960	960	ns	Blanking	TbpbH+TbplH+PWhs	40	128	160	ns	Clock	Period	Tck	11.75	13.85	15.38	ns	Frequency	Freq	60	72	87.5	MHz	Frame Rate	Frequency	1/Fr	30	60	75	Hz	Horizontal Frequency	Frequency	1/Fh	40	60	80	Hz
Signal	Item	Symbol	Min	Typ	Max	Unit																																																																																																																																						
Vertical Section	Period	Tp	1090	1100	1150	ns																																																																																																																																						
	Active	Tasp	1080	1080	1080	ns																																																																																																																																						
	Blanking	Tbpb+Tbpl+PWhs	10	20	80	ns																																																																																																																																						
Horizontal Section	Period	Th	1000	1085	1120	ns																																																																																																																																						
	Active	TaspH	960	960	960	ns																																																																																																																																						
	Blanking	TbpbH+TbplH+PWhs	40	128	160	ns																																																																																																																																						
Clock	Period	Tck	11.75	13.85	15.38	ns																																																																																																																																						
	Frequency	Freq	60	72	87.5	MHz																																																																																																																																						
Frame Rate	Frequency	1/Fr	30	60	75	Hz																																																																																																																																						
	Signal	Item	Symbol	Min	Typ	Max	Unit																																																																																																																																					
Vertical Section	Period	Tp	1090	1100	1150	ns																																																																																																																																						
	Active	Tasp	1080	1080	1080	ns																																																																																																																																						
	Blanking	Tbpb+Tbpl+PWhs	10	20	80	ns																																																																																																																																						
Horizontal Section	Period	Th	1000	1088	1120	ns																																																																																																																																						
	Active	TaspH	960	960	960	ns																																																																																																																																						
	Blanking	TbpbH+TbplH+PWhs	40	128	160	ns																																																																																																																																						
Clock	Period	Tck	11.75	13.85	15.38	ns																																																																																																																																						
	Frequency	Freq	60	72	87.5	MHz																																																																																																																																						
Frame Rate	Frequency	1/Fr	30	60	75	Hz																																																																																																																																						
	Horizontal Frequency	Frequency	1/Fh	40	60	80	Hz																																																																																																																																					
		19	<table border="1"> <thead> <tr> <th rowspan="2">Parameter</th> <th colspan="3">Value</th> <th rowspan="2">Units</th> </tr> <tr> <th>Min</th> <th>Typ</th> <th>Max</th> </tr> </thead> <tbody> <tr> <td>T1</td> <td>0.5</td> <td>---</td> <td>10</td> <td rowspan="5">ms</td> </tr> <tr> <td>T2</td> <td>30</td> <td>40</td> <td>50</td> </tr> <tr> <td>T11</td> <td>0</td> <td>16</td> <td>50</td> </tr> <tr> <td>T12</td> <td>---</td> <td>---</td> <td>10</td> </tr> <tr> <td>T13</td> <td>1000</td> <td>---</td> <td>---</td> </tr> </tbody> </table>	Parameter	Value			Units	Min	Typ	Max	T1	0.5	---	10	ms	T2	30	40	50	T11	0	16	50	T12	---	---	10	T13	1000	---	---	<table border="1"> <thead> <tr> <th rowspan="2">Parameter</th> <th colspan="3">Value</th> <th rowspan="2">Units</th> </tr> <tr> <th>Min</th> <th>Typ</th> <th>Max</th> </tr> </thead> <tbody> <tr> <td>T1</td> <td>0.5</td> <td>---</td> <td>10</td> <td rowspan="5">ms</td> </tr> <tr> <td>T2</td> <td>30</td> <td>40</td> <td>50</td> </tr> <tr> <td>T3</td> <td>0</td> <td>16</td> <td>50</td> </tr> <tr> <td>T4</td> <td>---</td> <td>---</td> <td>10</td> </tr> <tr> <td>T5</td> <td>1000</td> <td>---</td> <td>---</td> </tr> </tbody> </table>	Parameter	Value			Units	Min	Typ	Max	T1	0.5	---	10	ms	T2	30	40	50	T3	0	16	50	T4	---	---	10	T5	1000	---	---																																																																														
Parameter	Value				Units																																																																																																																																							
	Min	Typ	Max																																																																																																																																									
T1	0.5	---	10	ms																																																																																																																																								
T2	30	40	50																																																																																																																																									
T11	0	16	50																																																																																																																																									
T12	---	---	10																																																																																																																																									
T13	1000	---	---																																																																																																																																									
Parameter	Value			Units																																																																																																																																								
	Min	Typ	Max																																																																																																																																									
T1	0.5	---	10	ms																																																																																																																																								
T2	30	40	50																																																																																																																																									
T3	0	16	50																																																																																																																																									
T4	---	---	10																																																																																																																																									
T5	1000	---	---																																																																																																																																									
	21	<b>7.2.1 Connector:</b> <table border="1"> <tr> <td>Connector Name / Designation</td> <td>Light Bar Connector</td> </tr> <tr> <td>Manufacturer</td> <td>E&amp;T</td> </tr> <tr> <td>Type</td> <td>7182K-F06H-003 (6 Pin FFC Type)</td> </tr> </table>	Connector Name / Designation	Light Bar Connector	Manufacturer	E&T	Type	7182K-F06H-003 (6 Pin FFC Type)	<b>7.2.1 Connector:</b> <table border="1"> <tr> <td>Connector Name / Designation</td> <td>Light Bar Connector</td> </tr> <tr> <td>Manufacturer</td> <td>E&amp;T</td> </tr> <tr> <td>Type</td> <td>7182K-F06N-001 (6 Pin FFC Type)</td> </tr> </table>	Connector Name / Designation	Light Bar Connector	Manufacturer	E&T	Type	7182K-F06N-001 (6 Pin FFC Type)																																																																																																																													
Connector Name / Designation	Light Bar Connector																																																																																																																																											
Manufacturer	E&T																																																																																																																																											
Type	7182K-F06H-003 (6 Pin FFC Type)																																																																																																																																											
Connector Name / Designation	Light Bar Connector																																																																																																																																											
Manufacturer	E&T																																																																																																																																											
Type	7182K-F06N-001 (6 Pin FFC Type)																																																																																																																																											
V0.3 & 2017/01/11	6	<table border="1"> <thead> <tr> <th>Color</th> <th>Chromaticity Coordinates (CIE)</th> <th>±0.05</th> </tr> </thead> <tbody> <tr> <td>Red</td> <td>0.64</td> <td>0.05</td> </tr> <tr> <td>Red</td> <td>0.64</td> <td>0.05</td> </tr> <tr> <td>Green</td> <td>0.28</td> <td>0.05</td> </tr> <tr> <td>Green</td> <td>0.28</td> <td>0.05</td> </tr> <tr> <td>Blue</td> <td>0.15</td> <td>0.05</td> </tr> <tr> <td>Blue</td> <td>0.15</td> <td>0.05</td> </tr> <tr> <td>White</td> <td>0.31</td> <td>0.05</td> </tr> <tr> <td>White</td> <td>0.31</td> <td>0.05</td> </tr> </tbody> </table>	Color	Chromaticity Coordinates (CIE)	±0.05	Red	0.64	0.05	Red	0.64	0.05	Green	0.28	0.05	Green	0.28	0.05	Blue	0.15	0.05	Blue	0.15	0.05	White	0.31	0.05	White	0.31	0.05	<table border="1"> <thead> <tr> <th>Color</th> <th>Chromaticity Coordinates (CIE)</th> <th>±0.05</th> </tr> </thead> <tbody> <tr> <td>Red</td> <td>0.64</td> <td>0.05</td> </tr> <tr> <td>Red</td> <td>0.64</td> <td>0.05</td> </tr> <tr> <td>Green</td> <td>0.28</td> <td>0.05</td> </tr> <tr> <td>Green</td> <td>0.28</td> <td>0.05</td> </tr> <tr> <td>Blue</td> <td>0.15</td> <td>0.05</td> </tr> <tr> <td>Blue</td> <td>0.15</td> <td>0.05</td> </tr> <tr> <td>White</td> <td>0.31</td> <td>0.05</td> </tr> <tr> <td>White</td> <td>0.31</td> <td>0.05</td> </tr> </tbody> </table>	Color	Chromaticity Coordinates (CIE)	±0.05	Red	0.64	0.05	Red	0.64	0.05	Green	0.28	0.05	Green	0.28	0.05	Blue	0.15	0.05	Blue	0.15	0.05	White	0.31	0.05	White	0.31	0.05																																																																																			
Color	Chromaticity Coordinates (CIE)	±0.05																																																																																																																																										
Red	0.64	0.05																																																																																																																																										
Red	0.64	0.05																																																																																																																																										
Green	0.28	0.05																																																																																																																																										
Green	0.28	0.05																																																																																																																																										
Blue	0.15	0.05																																																																																																																																										
Blue	0.15	0.05																																																																																																																																										
White	0.31	0.05																																																																																																																																										
White	0.31	0.05																																																																																																																																										
Color	Chromaticity Coordinates (CIE)	±0.05																																																																																																																																										
Red	0.64	0.05																																																																																																																																										
Red	0.64	0.05																																																																																																																																										
Green	0.28	0.05																																																																																																																																										
Green	0.28	0.05																																																																																																																																										
Blue	0.15	0.05																																																																																																																																										
Blue	0.15	0.05																																																																																																																																										
White	0.31	0.05																																																																																																																																										
White	0.31	0.05																																																																																																																																										
V1.0 & 2017/04/10	5	<table border="1"> <tr> <td>Power Consumption</td> <td>10.7 W/typ</td> </tr> <tr> <td>Weight</td> <td>18.13 g/Wb + Cell 2.9 (20)</td> </tr> </table>	Power Consumption	10.7 W/typ	Weight	18.13 g/Wb + Cell 2.9 (20)	<table border="1"> <tr> <td>Power Consumption</td> <td>10.7 W/typ</td> </tr> <tr> <td>Weight</td> <td>18.13 g/Wb + Cell 2.9 (20)</td> </tr> </table>	Power Consumption	10.7 W/typ	Weight	18.13 g/Wb + Cell 2.9 (20)																																																																																																																																	
Power Consumption	10.7 W/typ																																																																																																																																											
Weight	18.13 g/Wb + Cell 2.9 (20)																																																																																																																																											
Power Consumption	10.7 W/typ																																																																																																																																											
Weight	18.13 g/Wb + Cell 2.9 (20)																																																																																																																																											
	11	<b>4.1 Absolute Ratings of TFT-LCD Module</b> <table border="1"> <thead> <tr> <th>Item</th> <th>Symbol</th> <th>Min</th> <th>Max</th> <th>Unit</th> <th>Condition</th> </tr> </thead> <tbody> <tr> <td>Log. LCD Drive Voltage</td> <td>V<sub>CC</sub></td> <td>0</td> <td>5</td> <td>V<sub>CC</sub></td> <td>Note 1, 2</td> </tr> </tbody> </table>	Item	Symbol	Min	Max	Unit	Condition	Log. LCD Drive Voltage	V <sub>CC</sub>	0	5	V <sub>CC</sub>	Note 1, 2	<b>4.1 Absolute Ratings of TFT-LCD Module</b> <table border="1"> <thead> <tr> <th>Item</th> <th>Symbol</th> <th>Min</th> <th>Max</th> <th>Unit</th> <th>Condition</th> </tr> </thead> <tbody> <tr> <td>Log. LCD Drive Voltage</td> <td>V<sub>CC</sub></td> <td>0</td> <td>5</td> <td>V<sub>CC</sub></td> <td>Note 1, 2</td> </tr> </tbody> </table>	Item	Symbol	Min	Max	Unit	Condition	Log. LCD Drive Voltage	V <sub>CC</sub>	0	5	V <sub>CC</sub>	Note 1, 2																																																																																																																	
Item	Symbol	Min	Max	Unit	Condition																																																																																																																																							
Log. LCD Drive Voltage	V <sub>CC</sub>	0	5	V <sub>CC</sub>	Note 1, 2																																																																																																																																							
Item	Symbol	Min	Max	Unit	Condition																																																																																																																																							
Log. LCD Drive Voltage	V <sub>CC</sub>	0	5	V <sub>CC</sub>	Note 1, 2																																																																																																																																							
	12	<p>VDD rising time</p>	<p>VCC rising time</p>																																																																																																																																									
	17	Pin1 location Drawing of connectors	Updated drawing																																																																																																																																									

## Contents

<b>1. Handling Precautions</b> .....	<b>4</b>
<b>2. General Description</b> .....	<b>5</b>
2.1 Display Characteristics .....	5
2.2 Optical Characteristics.....	6
<b>3. Functional Block Diagram</b> .....	<b>10</b>
<b>4. Absolute Maximum Ratings</b> .....	<b>11</b>
4.1 Absolute Ratings of TFT LCD Module .....	11
4.2 Absolute Ratings of Backlight Unit.....	11
4.3 Absolute Ratings of Environment .....	11
<b>5. Electrical characteristics</b> .....	<b>12</b>
5.1 TFT LCD Module .....	12
5.2 Backlight Unit.....	13
<b>6. Signal Characteristic</b> .....	<b>14</b>
6.1 Pixel Format Image .....	14
6.2 The Input Data Format .....	15
6.3 Signal Description.....	16
6.4 Interface Timing .....	18
6.5 Power ON/OFF Sequence.....	19
<b>7. Connector &amp; Pin Assignment</b> .....	<b>20</b>
7.1 TFT LCD Module .....	20
7.2 Backlight Unit.....	21
<b>8. Reliability Test</b> .....	<b>22</b>
<b>9. Shipping Label and Packaging</b> .....	<b>23</b>
9.1 Shipping Label.....	23
9.2 Packaging.....	23
<b>10. Mechanical Characteristic</b> .....	<b>24</b>

## 1. Handling Precautions

- 1) Since front polarizer is easily damaged, pay attention not to scratch it.
- 2) Be sure to turn off power supply when inserting or disconnecting from input connector.
- 3) Wipe off water drop immediately. Long contact with water may cause discoloration or spots.
- 4) When the panel surface is soiled, wipe it with absorbent cotton or other soft cloth.
- 5) Since the panel is made of glass, it may break or crack if dropped or bumped on hard surface.
- 6) Since CMOS LSI is used in this module, take care of static electricity and insure human earth when handling.
- 7) Do not open or modify the Module Assembly.
- 8) Do not press the reflector sheet at the back of the module to any directions.
- 9) In case if a Module has to be put back into the packing container slot after once it was taken out from the container, do not press the center of LED light bar edge. Instead, press at the far ends of LED light bar edge softly. Otherwise the TFT Module may be damaged.
- 10) At the insertion or removal of the Signal Interface Connector, be sure not to rotate nor tilt the Interface Connector of the TFT Module.
- 11) After installation of the TFT Module into an enclosure, do not twist nor bend the TFT Module even momentary. At designing the enclosure, it should be taken into consideration that no bending/twisting forces are applied to the TFT Module from outside. Otherwise the TFT Module may be damaged.
- 12) Small amount of materials having no flammability grade is used in the LCD module. The LCD module should be supplied by power complied with requirements of Limited Power Source (IEC60950 or UL1950), or be applied exemption.
- 13) Don't display the fixed pattern for a long time to avoid image sticking. If the fixed pattern is displayed on the screen, use a screen saver.
- 14) Avoid stressing front bezel position when doing mechanical design. This product must be installed by using mounting holes without undue such as bending or twist. Also do not add undue stress to any portion, ex: near bezel area. Bending or twist may cause this display mura or light leakage.  
Recommended installing method: The plane "A" is defined from one mounting hole to other mounting holes. Plane A must be the same plane within +/-0.3 mm.

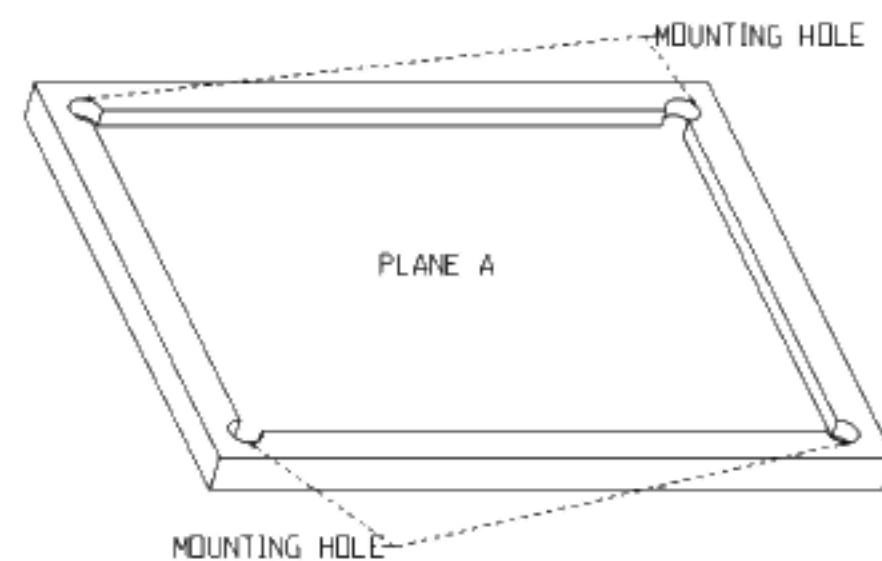

- 15) Do not operate or store in high temperature, high humidity, dewdrop atmosphere or corrosive gases. Keep the product in packing box with antistatic package in room temperature to avoid dusts when store the product.



## 2. General Description

G230HAN01.1 is a Color Active Matrix Liquid Crystal Display composed of a TFT-LCD panel, a driver circuit, and a backlight system. The screen format is intended to support the FHD (1920(H) x 1080(V)) screen and 16.7M colors. All input signals are 2-channel LVDS interface compatible.

### 2.1 Display Characteristics

The following items are characteristics summary on the table under 25 °C condition:

Items	Unit	Specifications
Screen Diagonal	[mm]	584.211 (23.0" )
Active Area	[mm]	509.184 (H) x 286.416 (V)
Resolution		1920(x3) x 1080
Pixel Pitch	[mm]	0.2652 (per one triad) x 0.2652
Pixel Arrangement		R.G.B. Vertical Stripe
Display Mode		Normally Black
White Luminance	[cd/m <sup>2</sup> ]	300 (center, Typ) @60mA
Contrast Ratio		1000 : 1 (Typ)
Optical ResponseTime	[msec]	14 (Gray to Gray)
Nominal Input Voltage	[Volt]	+5.0 V (Typ)
Power Consumption	[Watt]	22.0 W (max) (BL: 15.6 (W) + Cell: 6.4 (W))
Weight	[Grams]	1,500 (Typ) +/-150g
Physical Size	[mm]	533.2 (H) x 312.0 (V) x 10.5 (D) (Typ)
Electrical Interface		Dual channel LVDS
Surface Treatment		Anti-Glare treatment
Support Color		16.7M colors (True 8 bits)
Temperature Range Operating	[°C]	0 to +50
Storage (Non-Operating)	[°C]	-20 to +60
RoHS Compliance		RoHS Compliance

## 2.2 Optical Characteristics

The optical characteristics are measured under stable conditions at 25°C (Room Temperature):

Item	Unit	Conditions	Min.	Typ.	Max.	Note
Viewing Angle	[degree]	Horizontal (Right) CR = 10 (Left)	80 80	89 89	-	1
		Vertical (Up) CR = 10 (Down)	80 80	89 89	-	
Luminance Uniformity	[%]	9 Points	75	80	-	2
Optical Response Time	[msec]	Gray to Gray	-	14	25	3,4,5
		Rising	-	8	18	
		Falling	-	8	18	
		Rising + Falling	-	16	36	
Color / Chromaticity Coordinates (CIE)		Red x	-0.05	0.643	+0.05	3
		Red y		0.335		
		Green x		0.306		
		Green y		0.607		
		Blue x		0.155		
		Blue y		0.062		
		White x		0.313		
		White y		0.329		
White Luminance (At LED= 80mA)	[cd/m <sup>2</sup> ]		240	300	-	3
Contrast Ratio			600	1000	-	3
Color gamut (CG, CIE1931)	[%]			72		

Note 1: Definition of viewing angle, measured by ELDIM (EZContrast 88)

Viewing angle is the measurement of contrast ratio  $\geq 10$ , at the screen center, over a 180° horizontal and 180° vertical range (off-normal viewing angles). The 180° viewing angle range is broken down as follows; 90° ( $\theta$ ) horizontal left and right and 90° ( $\Phi$ ) vertical, high (up) and low (down). The measurement direction is typically perpendicular to the display surface with the screen rotated about its center to develop the desired measurement viewing angle.

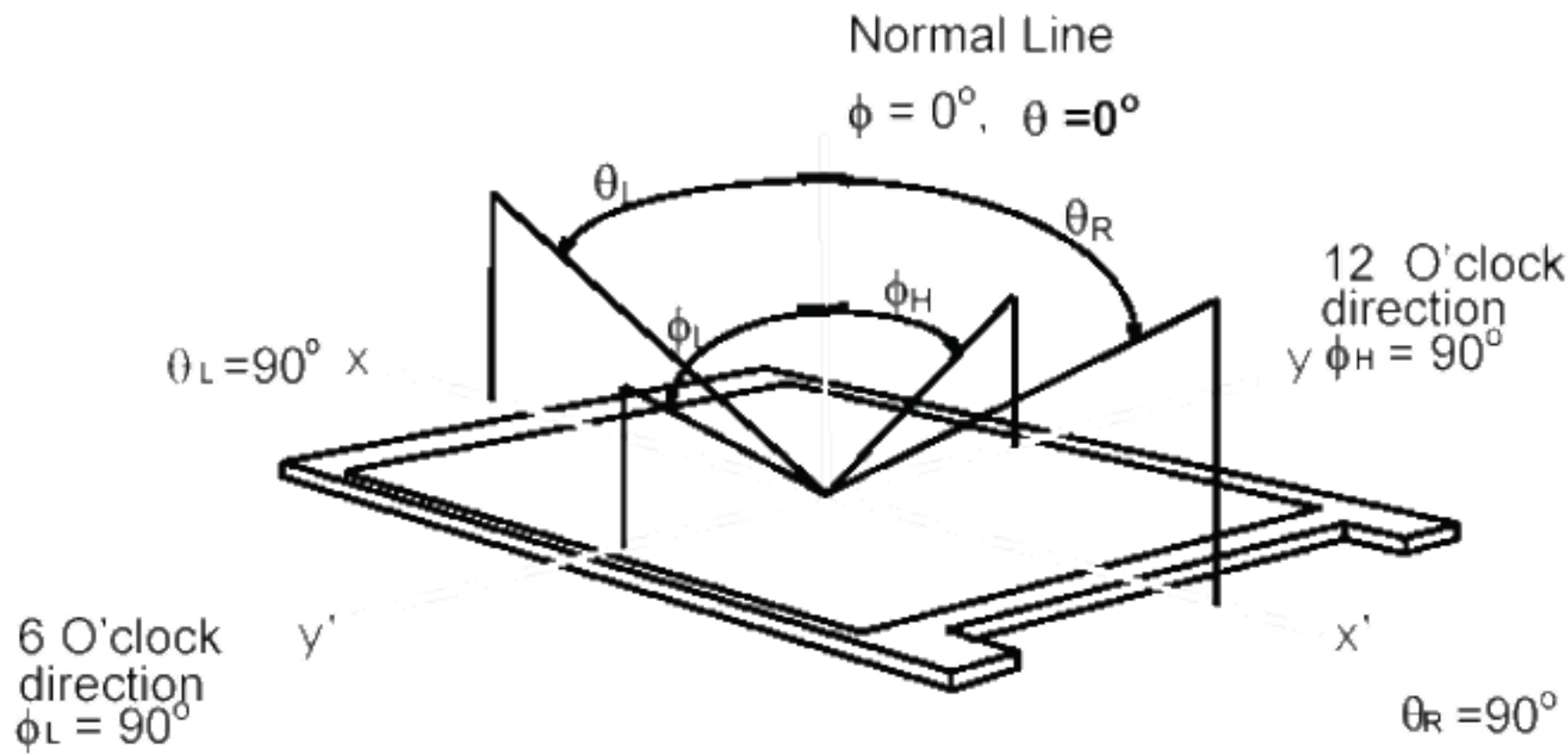

Note 2: The luminance uniformity of 9 points is defined by dividing the maximum luminance values by the minimum test point luminance. The luminance is measured by TOPCON SR-3. Detail 9 points position is as below.

$$\delta_{w9} = \frac{\text{Minimum Luminance of 9 points}}{\text{Maximum Luminance of 9 points}}$$

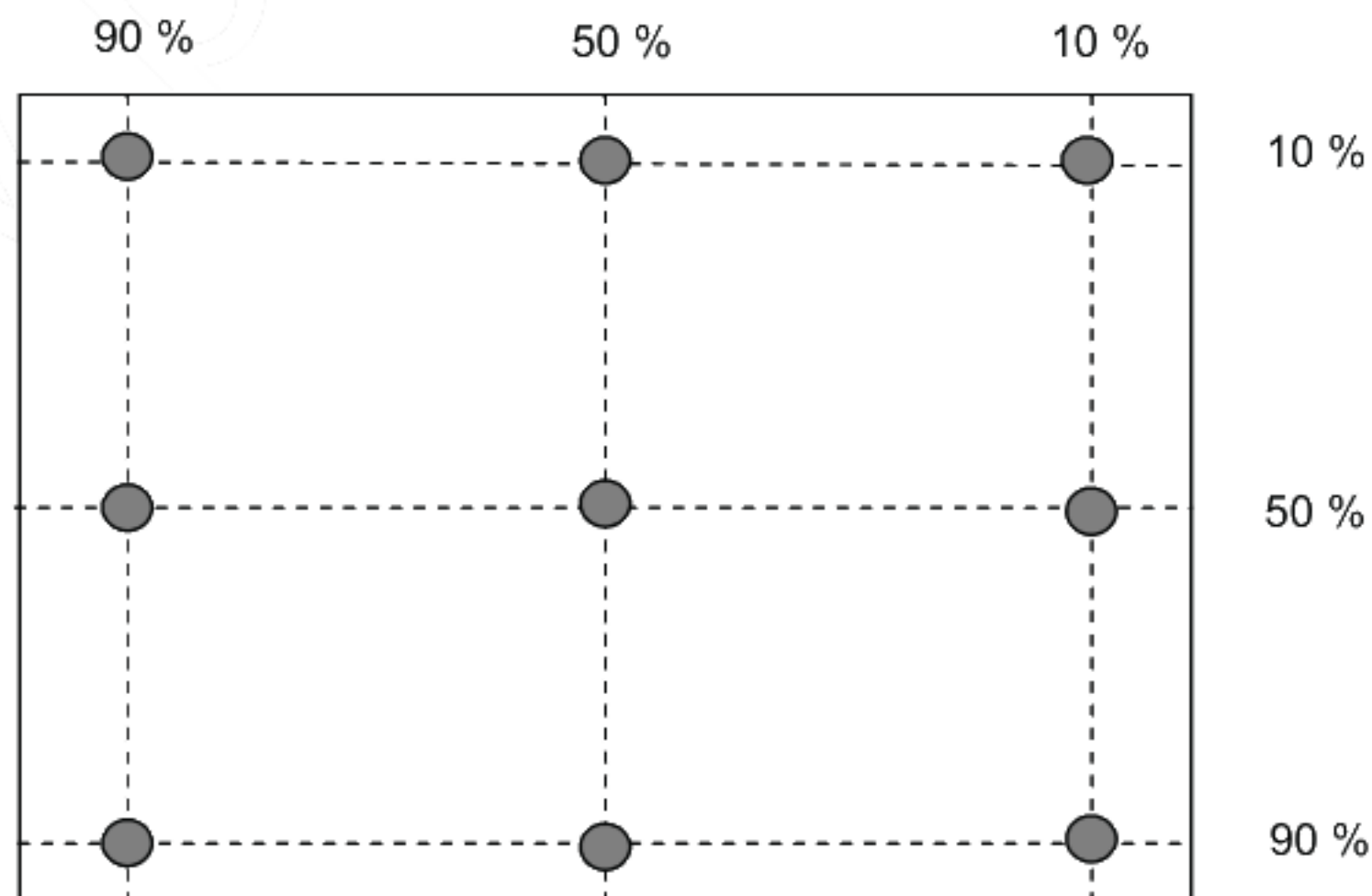

**Note 3: Measurement method**

The LCD module should be stabilized at given temperature for 30 minutes to avoid abrupt temperature change during measuring. In order to stabilize the luminance, the measurement should be executed after lighting Backlight for 30 minutes in a stable, windless and dark room.

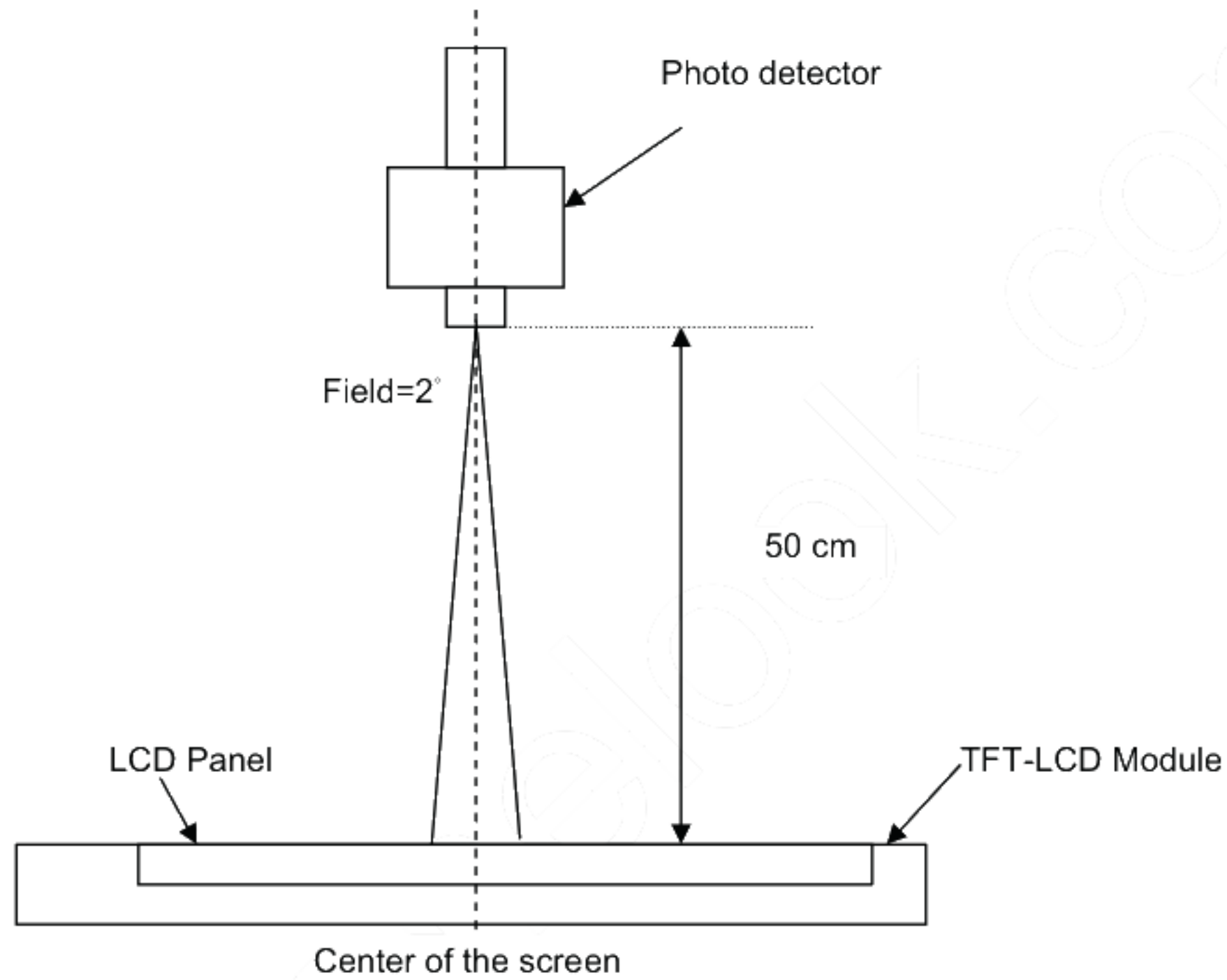

**Note 4:** The output signals of photo detector are measured when the input signals are changed from “Gray level A” to “Gray level B” (falling time,  $T_F$ ), and from “Gray level B” to “Gray level A” (rising time,  $T_R$ ), respectively. The response time is interval between the 10% and 90% of optical response. The gray to gray response time is defined as the following table.

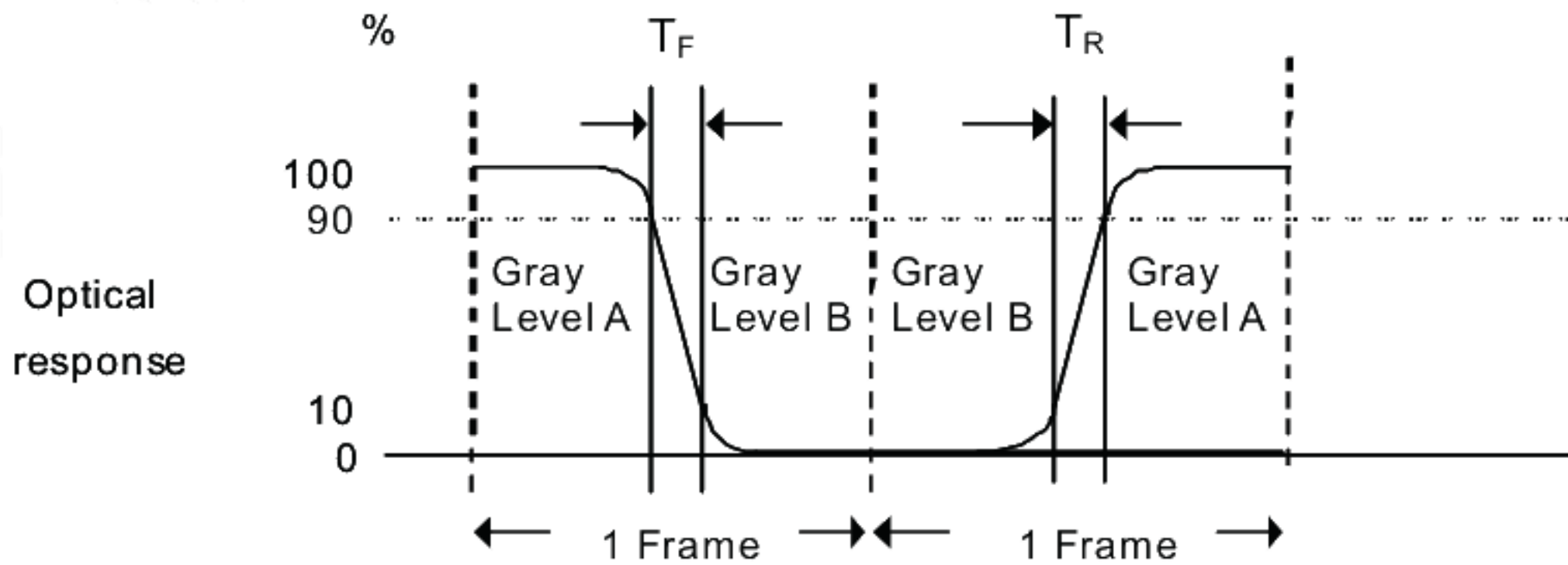



Gray Level to Gray Level		Falling Time				
		G0	G63	G127	G191	G255
Rising Time	G0					
	G63					
	G127					
	G191					
	G255					

■  $T_{GTG\_typ}$  is the total average time at rising time and falling time of gray to gray.

Note 5: Definition of response time, measured by WESTAR TRD-100A

The output signals of photo detector are measured when the input signals are changed from “Full Black” to “Full White” (rising time), and from “Full White” to “Full Black” (falling time), respectively. The response time is interval between the 10% and 90% of amplitudes. Please refer to the figure as below.

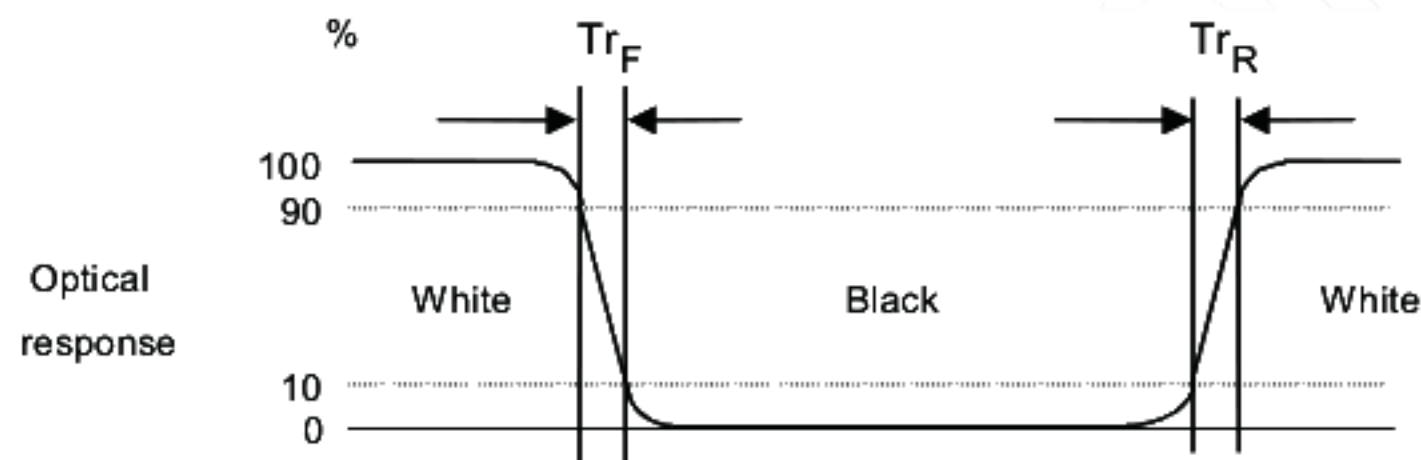

## 3. Functional Block Diagram

The following diagram shows the functional block of the 23 inches wide Color TFT-LCD Module:

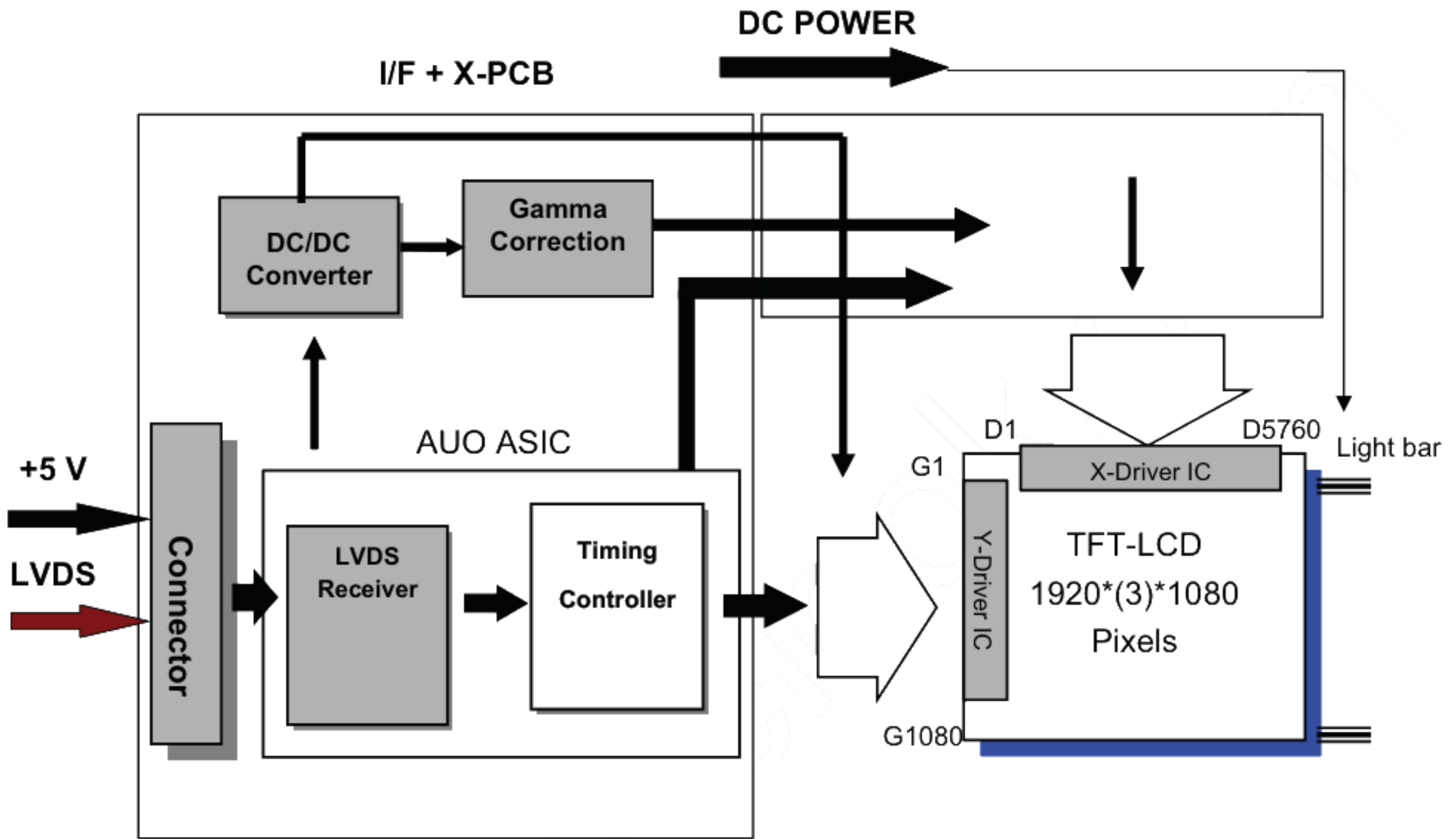

### I/F PCB Interface:

FI-XB30SSRLA-HF16 (JAE)

### Mating Type:

FI-X30HL (Locked Type)

FI-X30H (Unlocked Type)

FI-X30C2L (Manufactured by JAE) or Equivalent

## 4. Absolute Maximum Ratings

Absolute maximum ratings of the module are as following:

### 4.1 Absolute Ratings of TFT LCD Module

Item	Symbol	Min.	Max.	Unit	Conditions
Logic/LCD Drive Voltage	VCC	-0.3	+5.5	[Volt]	Note 1, 2

### 4.2 Absolute Ratings of Backlight Unit

Item	Symbol	Min.	Max.	Unit	Conditions
LED Power Current	Iled	-	1.7	[A] rms	Note 1, 2

### 4.3 Absolute Ratings of Environment

Item	Symbol	Min.	Max.	Unit	Conditions
Operating Temperature	TOP	0	+50	[°C]	Note 3
Operation Humidity	HOP	5	90	[%RH]	
Storage Temperature	TST	-20	+60	[°C]	
Storage Humidity	HST	5	90	[%RH]	

Note 1: With in Ta= 25°C

Note 2: Permanent damage to the device may occur if exceed maximum values

Note 3: For quality performance, please refer to AUO IIS (Incoming Inspection Standard).

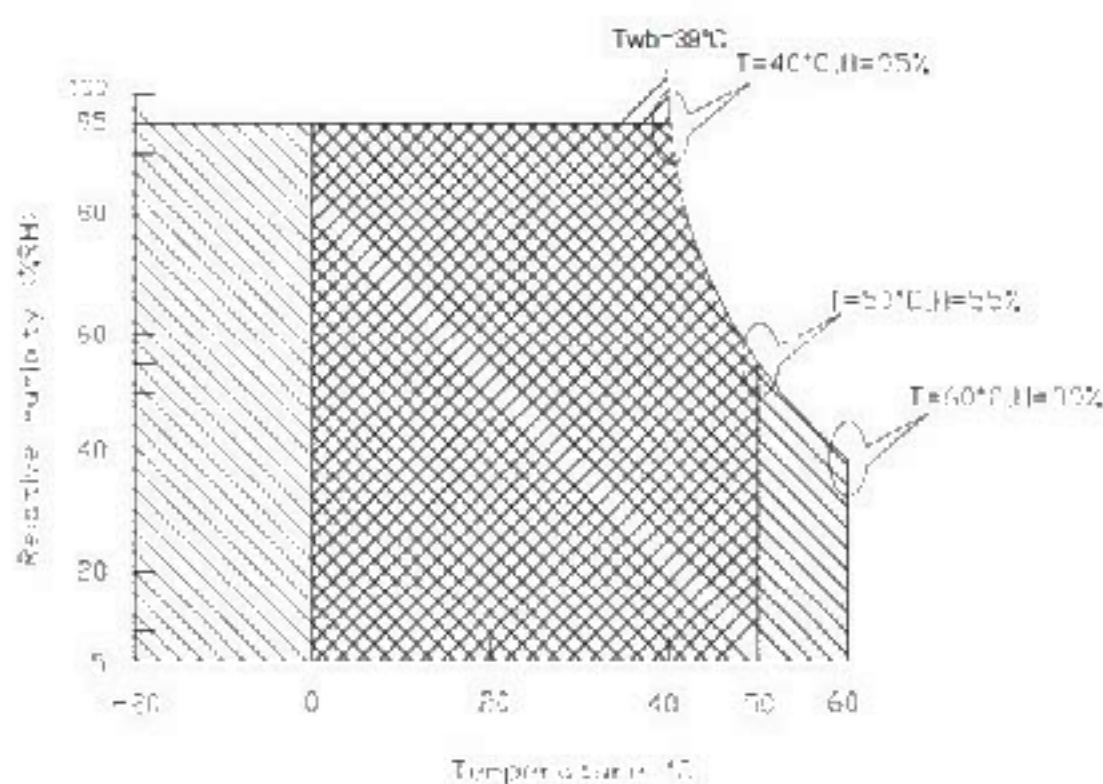

Operating Range 

Storage Range  

## 5. Electrical characteristics

### 5.1 TFT LCD Module

#### 5.1.1 Power Specification

Input power specifications are as follows:

Symble	Parameter	Min.	Typ.	Max.	Unit	Condition
VCC	Logic/LCD Drive Voltage	4.5	5.0	5.5	[Volt]	±10%
ICC	Input Current	-	1.17	1.27	[A]	Vin=5V, White Pattern, at 75Hz
IRush	Inrush Current	-	2.7	3.4	[A]	Note 1
PCC	VCC Power	-	5.85	6.35	[Watt]	Vin=5V, White Pattern, at 75Hz
VCCrp	Allowable Logic/LCD Drive Ripple Voltage	-	-	300	[mV] p-p	With panel loading

Note 1:

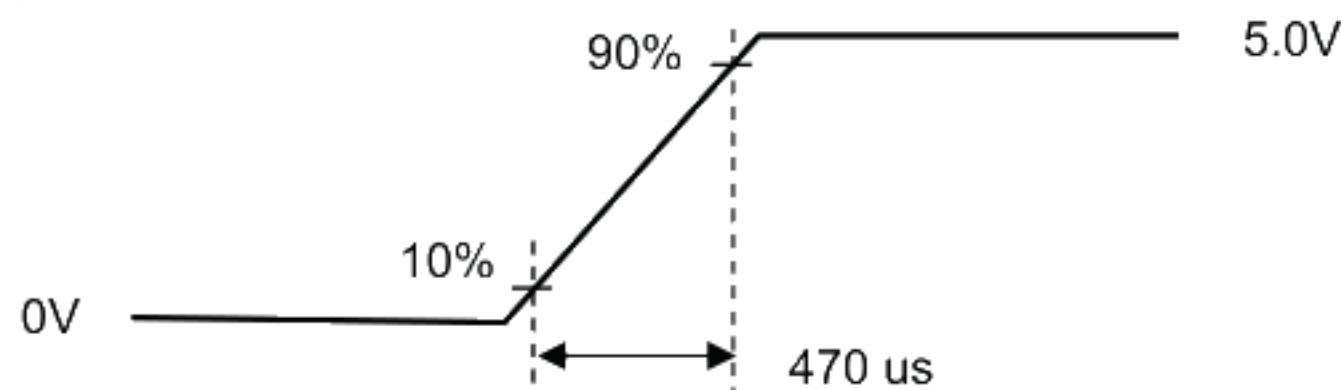
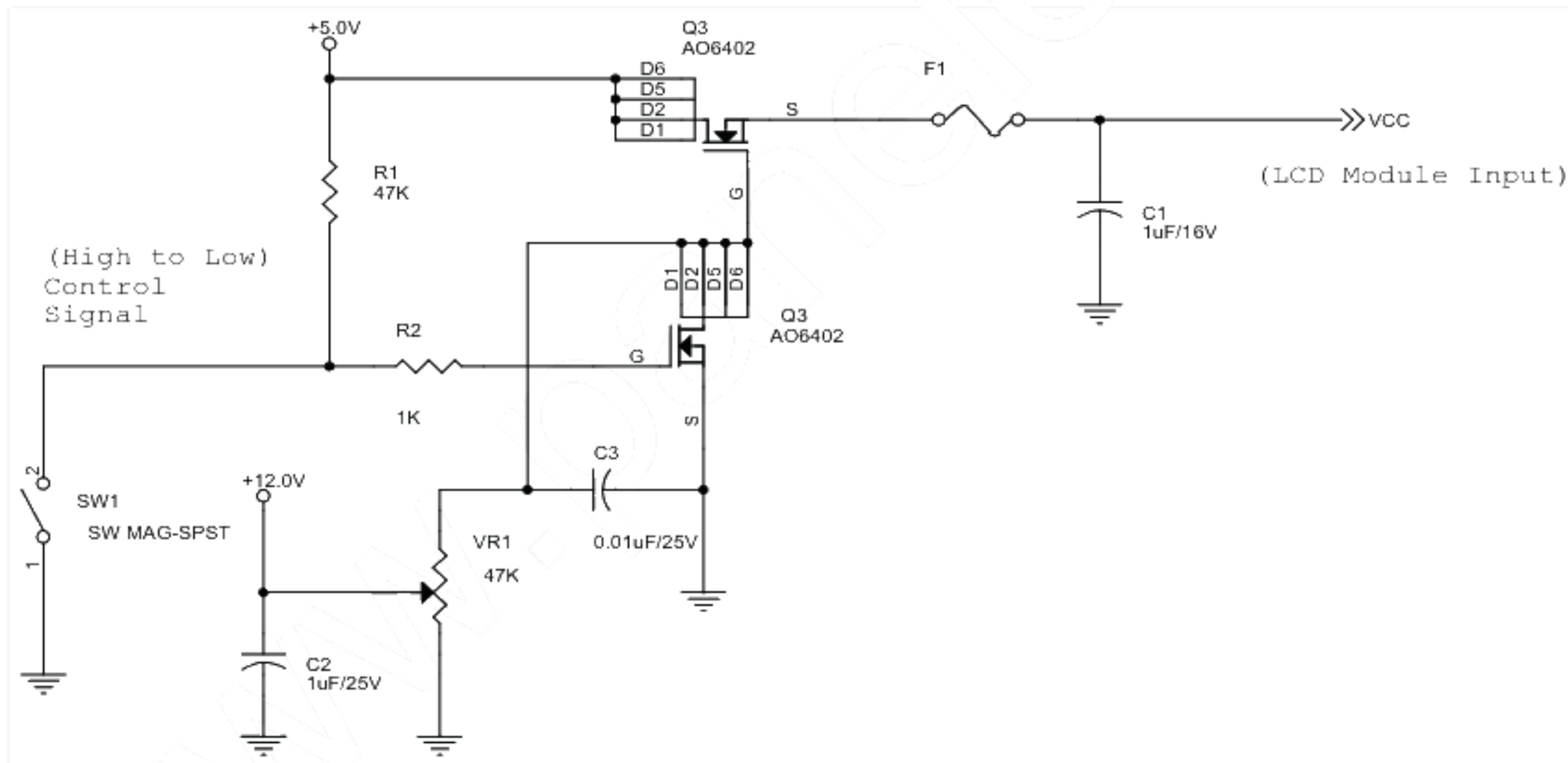

VCC rising time



## 5.2 Backlight Unit

Following characteristics are measured under a stable condition at 25 °C (Room Temperature):

Symbol	Parameter	Min.	Typ.	Max.	Unit	Remark
$I_F$	LED Forward Current		60		mA	$T_a = 25^\circ\text{C}$
$V_F$ LED	Forward Voltage		57.6	64.8	Volt	$I_F = 60\text{ mA}, T_a = 25^\circ\text{C}$
$P_{LED}$	LED Power Consumption	-	13.8	15.6	Watt	$I_F = 60\text{ mA}, T_a = 25^\circ\text{C}$
<b>LTLED</b>	LED Life Time	30,000			Hrs	$I_F = 60\text{ mA}, T_a = 25^\circ\text{C}$

Note 1:  $T_a$  means ambient temperature of TFT-LCD module.

Note 2:  $P_{LED}$ ,  $I_F$  are defined for LED B/L.(100% duty of PWM dimming)

Note 3:  $I_F$ ,  $V_F$  are defined for one channel LED.

Note 4: If module is driven by high current or at high ambient temperature & humidity condition. The operating life will be reduced.

Note 5: LED life means brightness goes down to 50% initial brightness.

Note 6: Two kind types for adjusting brightness: PWM and Analog.

Note 7: Each LED light bar consists of 72 pcs LED package ( 4 strings x 18 pcs / string ).

## 6. Signal Characteristic

### 6.1 Pixel Format Image

Following figure shows the relationship of the input signals and LCD pixel format.

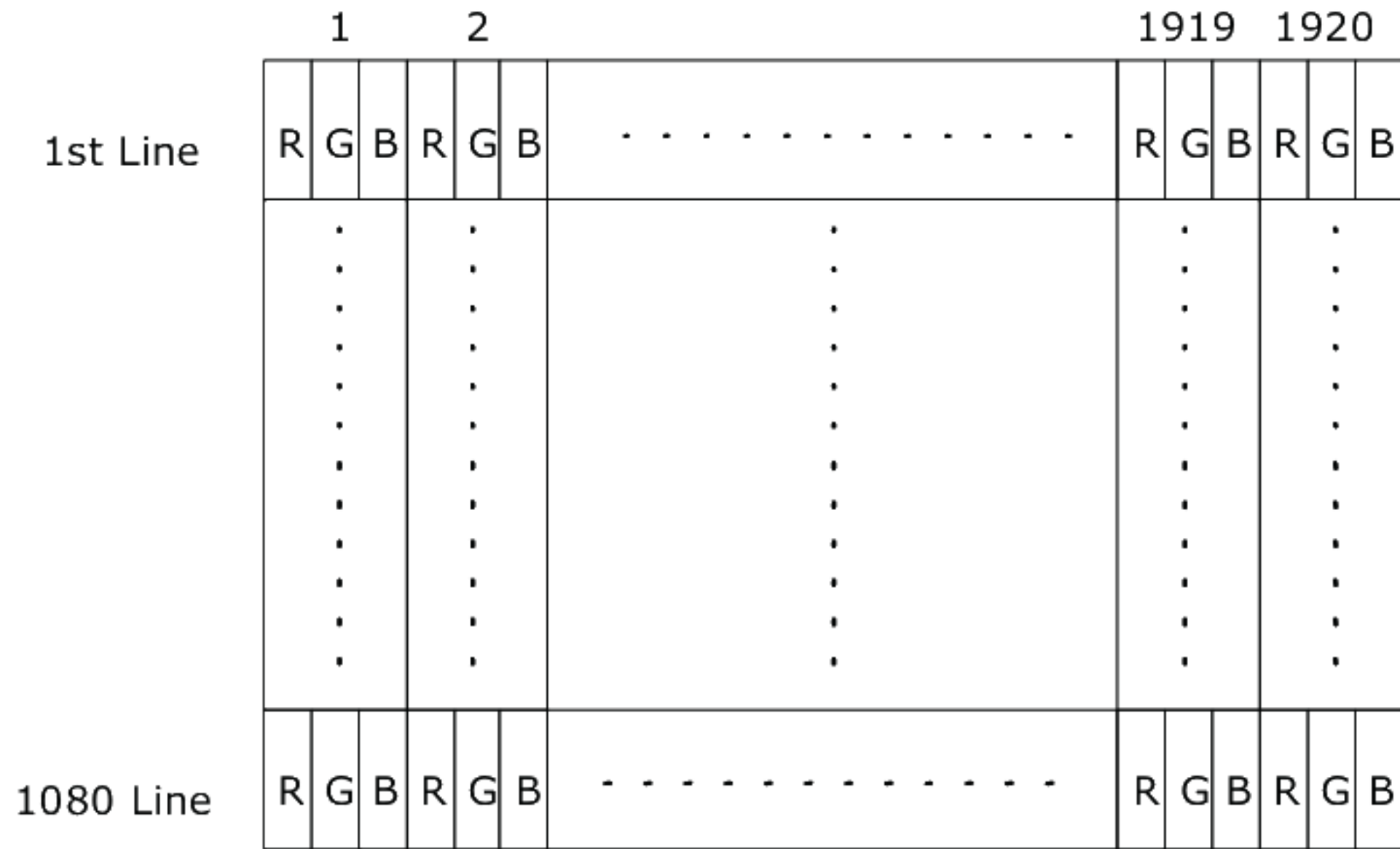

## 6.2 The Input Data Format

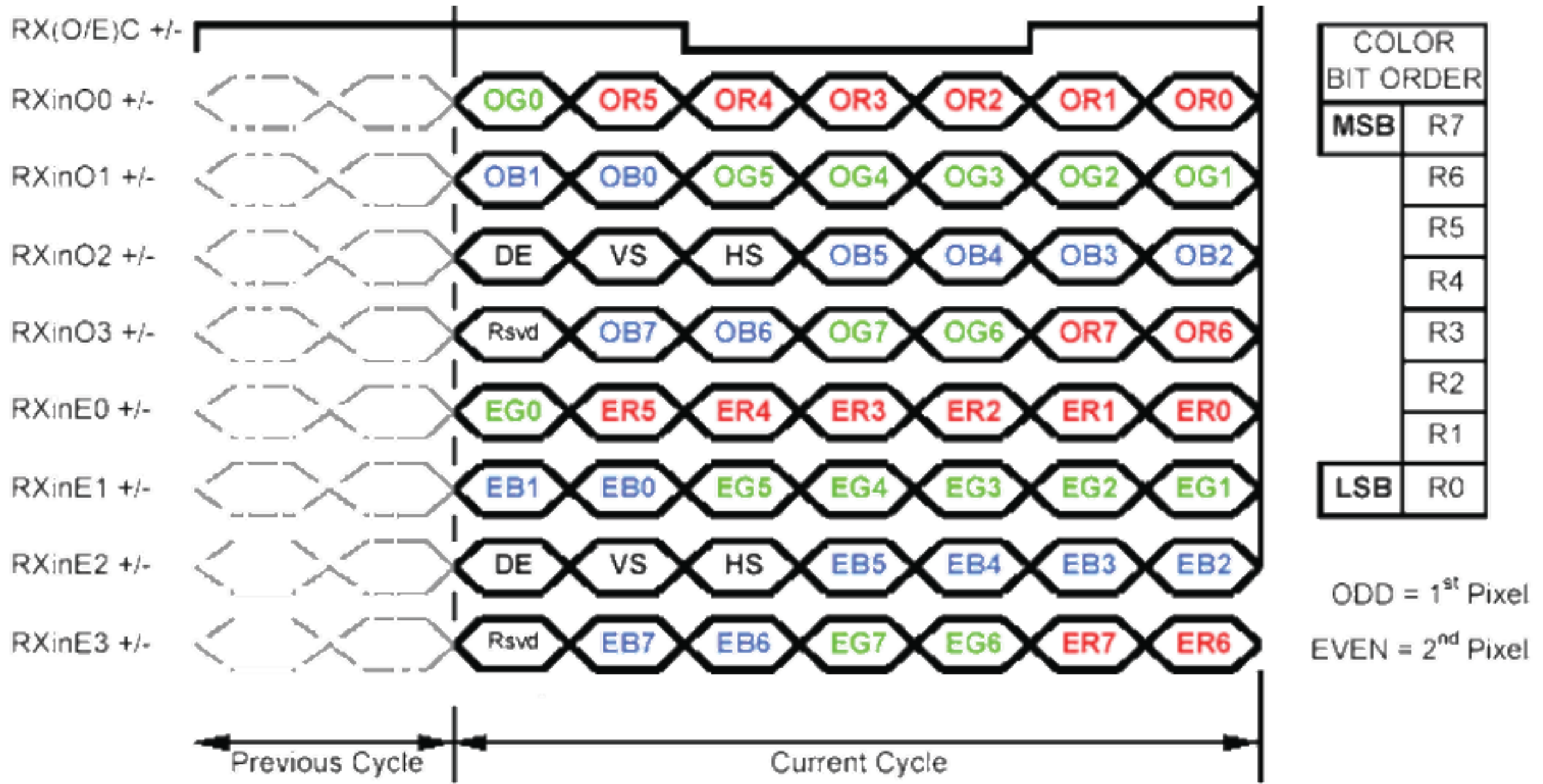

Note1: Normally DE mode only. VS and HS on EVEN channel are not used.

Note2: Please follow VESA.

Note3: 8-bit in



## 6.3 Signal Description

The module using a pair of LVDS receiver SN75LVDS82(Texas Instruments) or compatible. LVDS is a differential signal technology for LCD interface and high speed data transfer device. Transmitter shall be SN75LVDS83(negative edge sampling) or compatible. The first LVDS port(RxOxxx) transmits odd pixels while the second LVDS port(RxExxx) transmits even pixels.

PIN #	SIGNAL NAME	DESCRIPTION
1	RxOIN0-	Negative LVDS differential data input (Odd data)
2	RxOIN0+	Positive LVDS differential data input (Odd data)
3	RxOIN1-	Negative LVDS differential data input (Odd data)
4	RxOIN1+	Positive LVDS differential data input (Odd data)
5	RxOIN2-	Negative LVDS differential data input (Odd data, H-Sync,V-Sync,DSPTMG)
6	RxOIN2+	Positive LVDS differential data input (Odd data, H-Sync,V-Sync,DSPTMG)
7	VSS	Power Ground
8	RxOCLKIN-	Negative LVDS differential clock input (Odd clock)
9	RxOCLKIN+	Positive LVDS differential clock input (Odd clock)
10	RxOIN3-	Negative LVDS differential data input (Odd data)
11	RxOIN3+	Positive LVDS differential data input (Odd data)
12	RxEIN0-	Negative LVDS differential data input (Even data)
13	RxEIN0+	Positive LVDS differential data input (Even data)
14	VSS	Power Ground
15	RxEIN1-	Negative LVDS differential data input (Even data)
16	RxEIN1+	Positive LVDS differential data input (Even data)
17	VSS	Power Ground
18	RxEIN2-	Negative LVDS differential data input (Even data)
19	RxEIN2+	Positive LVDS differential data input (Even data)
20	RxECLKIN-	Negative LVDS differential clock input (Even clock)
21	RxECLKIN+	Positive LVDS differential clock input (Even clock)
22	RxEIN3-	Negative LVDS differential data input (Even data)
23	RxEIN3+	Positive LVDS differential data input (Even data)
24	VSS	Power GND
25	NC	NC
26	NC	NC
27	PWM_OUT	PWM_OUT
28	VCC	+5.0V Power Supply
29	VCC	+5.0V Power Supply
30	VCC	+5.0V Power Supply



Note1:

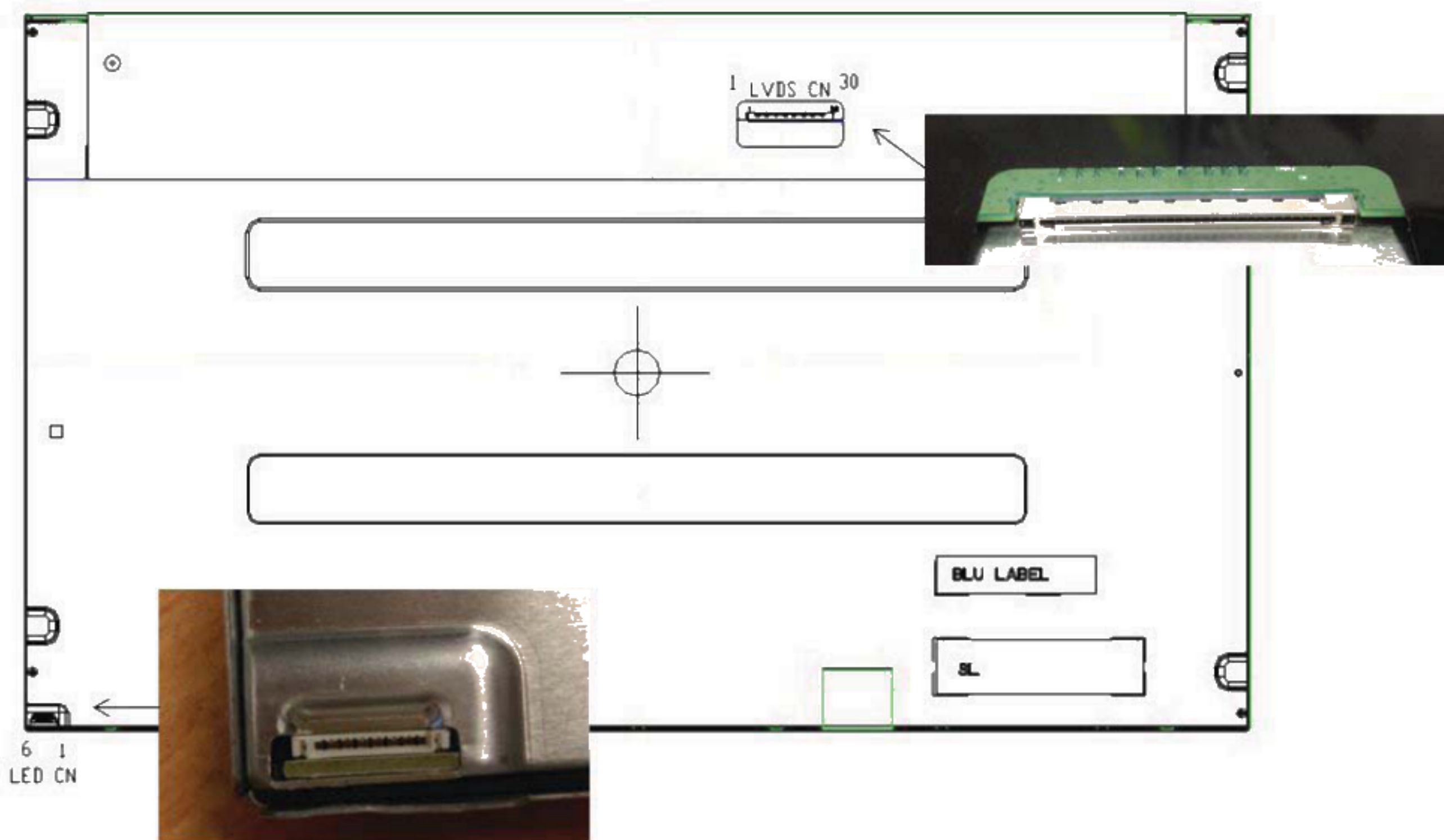

Note 2: All GND(ground) pins should be connected together and to be Vss which should also be connected to the LCD's metal frame.

Note 3: All Vcc (power input) pins should be connected together.

Note 4: Input level of LVDS signal is based on the IEA 664 Standard.

Note 5: PWM\_OUT signal controls the burst frequency of an inverter.

This signal is synchronized with vertical frequency.

Its frequency is 3 times of vertical frequency, and duty ratio is 50%.

If not use this pin then no connection

Note 6: Input signals of odd and even clock shall be the same timing.

Note 7: Please follow VESA.

## 6.4 Interface Timing

### 6.4.1 Timing Characteristics

Signal	Item	Symbol	Min	Typ	Max	Unit
Vertical Section	Period	$T_v$	1090	1100	1200	Th
	Active	$T_{disp}(v)$	1080	1080	1080	Th
	Blanking	$T_{bp}(v)+T_{fp}(v)+PW_{vs}$	10	20	120	Th
Horizontal Section	Period	$T_h$	1000	1088	1200	Tclk
	Active	$T_{disp}(h)$	960	960	960	Tclk
	Blanking	$T_{bp}(h)+T_{fp}(h)+PW_{hs}$	40	128	240	Tclk
Clock	Period	$T_{clk}$	11.76	13.89	15.38	ns
	Frequency	Freq.	60	72	87.5	MHz
Frame Rate	Frequency	$1/T_v$	49	60	75	Hz
Horizontal Frequency	Frequency	$F_h$	49	65.28	90	kHz

Note 1: Only DE mode operation.

The input of Hsync & Vsync signal does not have an effect upon the LCD normal operation.

Note 2: The performance of the electro-optical characteristics may be influenced by variance of the vertical refresh rates.

Note 3: Horizontal period should be even.

### 6.4.2 Timing Diagram

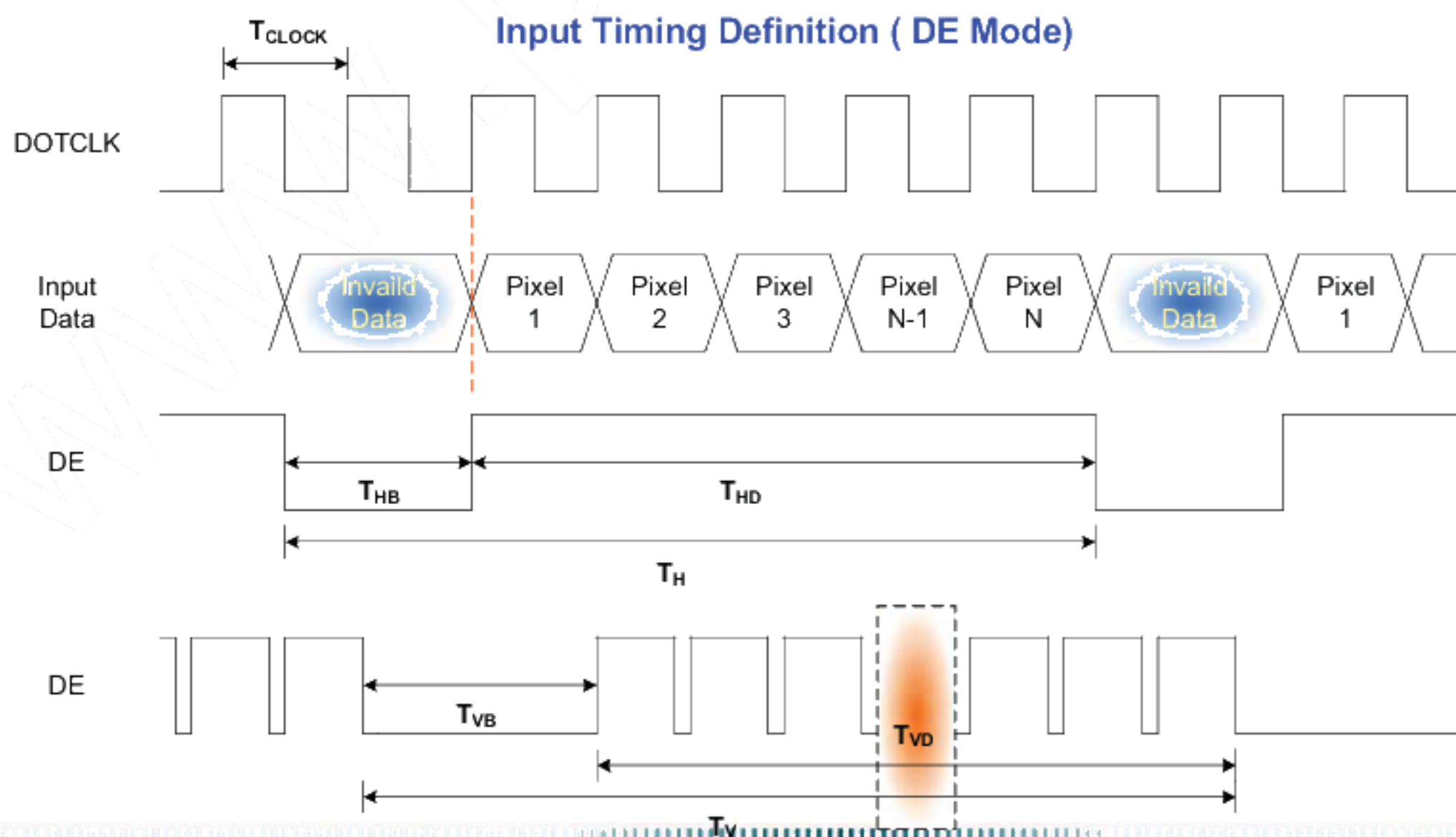

## 6.5 Power ON/OFF Sequence

VCC power on/off sequence is as follows. Interface signals are also shown in the chart. Signals from any system shall be Hi-Z state or low level when VCC is off.

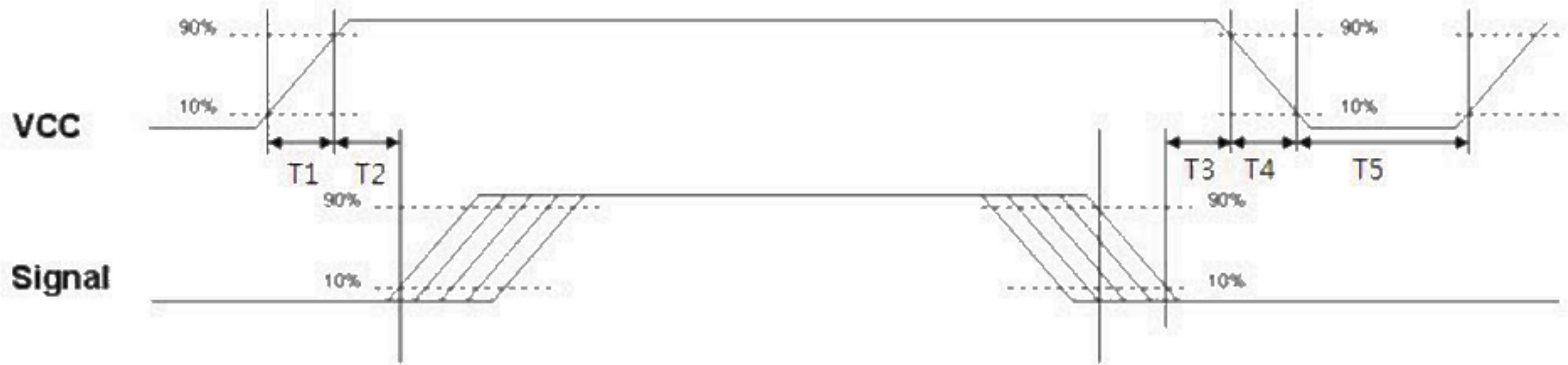

Power Sequence Timing

Power Sequence Timing				
Parameter	Value			Units
	Min.	Typ.	Max.	
T1	0.5	--	10	ms
T2	30	40	50	
T3	0	16	50	
T4	--	--	10	
T5	1000	--	--	

## 7. Connector & Pin Assignment

Physical interface is described as for the connector on module. These connectors are capable of accommodating the following signals and will be following components.

### 7.1 TFT LCD Module

#### 7.1.1 Connector

Connector Name / Designation	LVDS Connector
Manufacturer	JAE
Type Part Number	FI-XB30SSRLA-HF16
Mating Housing Part Number	FI-X30HL (Locked Type) FI-X30H (Unlocked Type) FI-X30C2L (JAE) or Equivalent

#### 7.1.2 Pin Assignment

Pin#	Signal Name	Pin#	Signal Name
1	RxOIN0-	2	RxOIN0+
3	RxOIN1-	4	RxOIN1+
5	RxOIN2-	6	RxOIN2+
7	VSS	8	RxOCLKIN-
9	RxOCLKIN+	10	RxOIN3-
11	RxOIN3+	12	RxEIN0-
13	RxEIN0+	14	VSS
15	RxEIN1-	16	RxEIN1+
17	VSS	18	RxEIN2-
19	RxEIN2+	20	RxECLKIN-
21	RxECLKIN+	22	RxEIN3-
23	RxEIN3+	24	VSS
25	NC	26	NC
27	PWM_OUT	28	VCC
29	VCC	30	VCC



## 7.2 Backlight Unit

### 7.2.1 Connector

Connector Name / Designation	Light Bar Connector
Manufacturer	E&T
Type	7182K-F06N-00L (6 Pin FFC Type)

### 7.2.2 Pin Assignment

Pin no.	Signal name
1	Current Feedback
2	Current Feedback
3	VLED (voltage in)
4	VLED (voltage in)
5	Current Feedback
6	Current Feedback

## 8. Reliability Test

Environment test conditions are listed as following table.

Items	Required Condition	Note
Temperature Humidity Bias (THB)	Ta= 50°C, 80%RH, 300hours	
High Temperature Operation (HTO)	Ta= 50°C, 300hours	
Low Temperature Operation (LTO)	Ta= 0°C, 300hours	
High Temperature Storage (HTS)	Ta= 60°C, 300hours	
Low Temperature Storage (LTS)	Ta= -20°C, 300hours	
Vibration Test (Non-operation)	Acceleration: 1.5 G Wave: Random Frequency: 10 - 200 - 10 Hz Sweep: 30 Minutes each Axis (X, Y, Z)	
Shock Test (Non-operation)	Acceleration: 50 G Wave: Half-sine Active Time: 20 ms Direction: ±X, ±Y, ±Z (one time for each Axis)	
Drop Test	Height: 60 cm, package test	
Thermal Shock Test (TST)	-20 °C /30min, 60/ °C 30min, 100 cycles	1
On/Off Test	On/10sec, Off/10sec, 30,000 cycles	
ESD (Electrostatic Discharge)	Contact Discharge: ± 8KV, 150pF(330Ω ) 1sec, 9 points, 25 times/ point.	2
	Air Discharge: ± 15KV, 150pF(330Ω ) 1sec 9 points, 25 times/ point.	
Altitude Test	Operation:10,000 ft Non-Operation:30,000 ft	

Note 1: The TFT-LCD module will not sustain damage after being subjected to 100 cycles of rapid temperature change. A cycle of rapid temperature change consists of varying the temperature from -20°C to 60°C, and back again. Power is not applied during the test. After temperature cycling, the unit is placed in normal room ambient for at least 4 hours before power on.

Note 2: According to EN61000-4-2 , ESD class B: Some performance degradation allowed. No data lost. Self-recoverable. No hardware failures.

Note 3:

- Water condensation is not allowed for each test items.
- Each test is done by new TFT-LCD module. Don't use the same TFT-LCD module repeatedly for reliability test.
- The reliability test is performed only to examine the TFT-LCD module capability.
- To inspect TFT-LCD module after reliability test, please store it at room temperature and room humidity for 24 hours at least in advance.
- No function failure occurs.

## 9. Shipping Label and Packaging

### 9.1 Shipping Label

The label is on the panel as shown below:

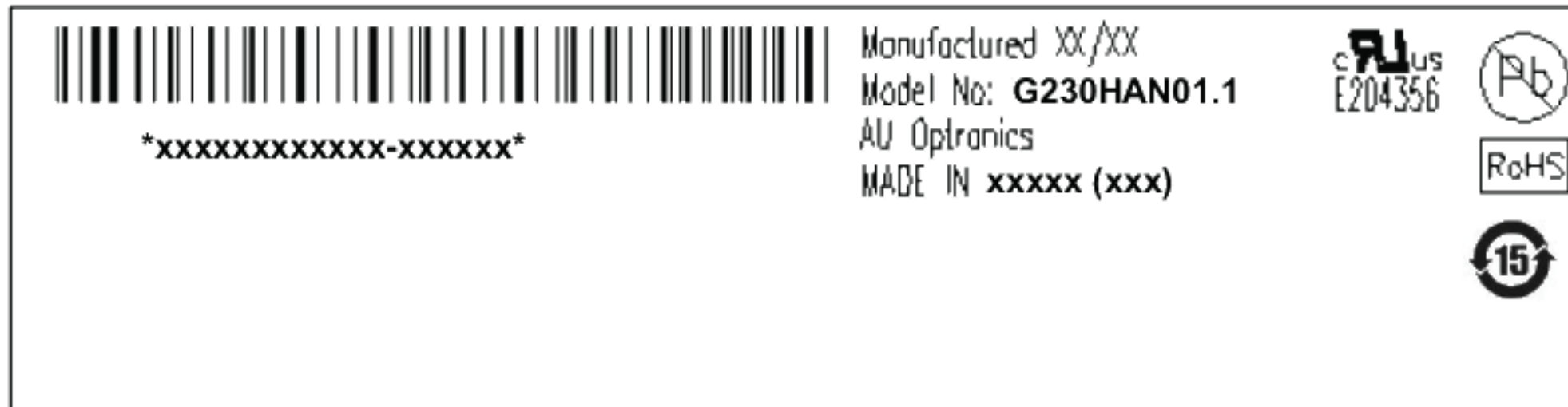

Note 1: For Pb Free products, AUO will add  for identification.

Note 2: For RoHS compatible products, AUO will add  for identification.

Note 3: For China RoHS compatible products, AUO will add  for identification.

Note 4: The Green Mark will be presented only when the green documents have been ready by AUO Internal Green Team.

### 9.2 Packaging

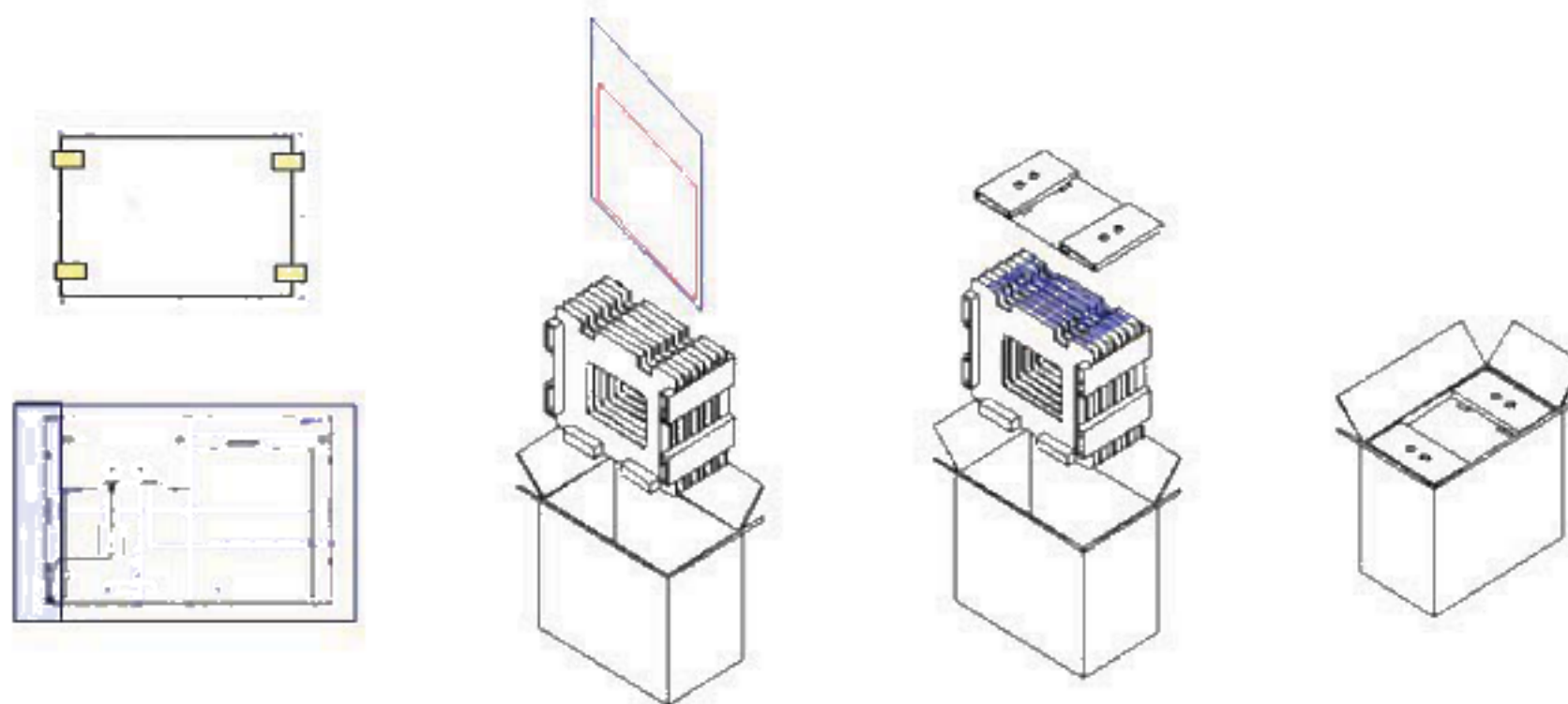

Max capacity : 8 PCS TFT-LCD module per carton

Max weight: 15.5 kg per carton

Outside dimension of carton: 620mm(L)\* 220mm(W)\*415mm(H)

Pallet size : 980 mm \* 740 mm \* 132mm

Box stacked

Module by air : (1\*4) \*3 layers , one pallet put 12 boxes , total 96pcs module

Module by sea : One pallet (1 \*4) \*3 layers + One pallet (1 \*4) \*1 layers , total 128 pcs module

Module by sea\_ HQ : One pallet (1 \*4) \*3 layers + One pallet (1 \*4) \*1 layers, total 128 pcs module



# Product Specification

G230HAN01.1

AU OPTRONICS CORPORATION

## 10. Mechanical Characteristic







# Product Specification

AU OPTRONICS CORPORATION

G230HAN01.1

