



(v) Preliminary Specifications

() Final Specifications

Module	17.0 Inch Color TFT-LCD
Model Name	G170HAN01.x

Customer	Date
_____	_____
Checked & Approved by	Date
_____	_____
Customer's sign back page	

Approved by	Date
Crystal Hsieh	2018/05/10
Prepared by	Date
BinJou Huang	2018/05/10
General Display Business Division / AU Optronics corporation	

Contents

1. Operating Precautions	4
2. General Description.....	5
2.1 Display Characteristics.....	5
2.2 Optical Characteristics	6
3. Functional Block Diagram.....	9
4. Absolute Maximum Ratings	10
4.1 Absolute Ratings of TFT LCD Module.....	10
4.2 Touch Sensor.....	10
4.3 Absolute Ratings of Environment.....	10
5. Electrical Characteristics	11
5.1 TFT LCD Module and Backlight Unit.....	11
6. Signal Characteristic	15
6.1 Pixel Format Image.....	15
6.2 Scanning Direction.....	15
6.3 Signal Description	16
6.4 Interface Timing	18
6.5 Power ON/OFF Sequence	19
7. Connector & Pin Assignment.....	20
7.1 TFT LCD Module: eDP Connector	20
8. Reliability Test Criteria	21
9. Mechanical Characteristics.....	22
9.1 LCM Outline Dimension	22
10. Label and Packaging	23
10.1 Shipping Label (on the rear side of TFT-LCD display)	23
10.2 Carton Package	23
11 Safety	25
11.1 Sharp Edge Requirements	25
11.2 Materials.....	25
11.3 Capacitors	25
11.4 National Test Lab Requirement.....	25

1. Operating Precautions

- 1) Be sure to turn off power supply when inserting or disconnecting from input connector.
- 2) When the panel surface is soiled, wipe it with absorbent cotton or other soft cloth.
- 3) Wipe off water drop immediately. Long contact with water may cause discoloration or spots.
- 4) Since the panel is made of glass, it may break or crack if dropped or bumped on hard surface.
- 5) Since CMOS LSI is used in this module, take care of static electricity and insure human earth when handling.
- 6) Do not open or modify the Module Assembly.
- 7) In case if a Module has to be put back into the packing container slot after once it was taken out from the container, take it easily, or the TFT Module may be damaged.
- 8) At the insertion or removal of the Signal Interface Connector, be sure not to rotate nor tilt the Interface Connector of the TFT Module.
- 9) After installation of the TFT Module into an enclosure, do not twist nor bend the TFT Module even momentary. At designing the enclosure, it should be taken into consideration that no bending/twisting forces are applied to the TFT Module from outside. Otherwise the TFT Module may be damaged.
- 10) Small amount of materials having no flammability grade is used in the LCD module. The LCD module should be supplied by power complied with requirements of Limited Power Source (IEC60950 or UL1950), or be applied exemption.
- 11) Severe temperature condition may result in different luminance, response time and LED life time.
- 12) The data on this specification sheet is applicable when LCD module is placed in landscape position.
- 13) Continuous displaying fixed pattern may induce image sticking. It is recommended to use screen saver or shuffle content periodically if fixed pattern is displayed on the screen.

2. General Description

This specification applies to the 17 inch square Color TFT-LCD Module. The display supports the resolution - 1920(H) x 1920(V) and 16.7M colors (RGB 8-bits data). All input signals are 4 lanes eDP (1.3) interface.

LED driver board is included. G170HAN01.x is designed for industrial display applications.

2.1 Display Characteristics

The following items are characteristics summary on the table under 25 °C condition:

ITEMS	Unit	SPECIFICATIONS
Screen Diagonal	[mm]	431.67(17.0")
Active Area	[mm]	305.28(H) x 305.28(V)
Pixels H x V		1920(xRGB) x 1920
Pixel Pitch	[mm]	0.159 (per one triad) x0.159
Pixel Arrangement		R.G.B. Vertical Stripe
Display Mode		AHVA Mode, Normally Black
White Luminance (Center)	[cd/m ²]	350 (Typ.)
Contrast Ratio		1000: 1
Optical Response Time	[msec]	25 (On/Off, Typ.)
Nominal Input Voltage VDD	[Volt]	12
Power Consumption	[Watt]	16.5 W (Max.)
Weight	[g]	1200g (Max.)
Physical Size	[mm]	325.01(H) x 319.33(V) x 11.73(D) (Typ.)
Electrical Interface		4 lanes eDP (1.3)
Support Color		16.7M colors (true 8-bit)
Surface Treatment		Glare, 3H
Temperature Range Operating Storage (Shipping)	[°C] [°C]	-20 to +60 -20 to +70
RoHS Compliance		RoHS Compliance

2.2 Optical Characteristics

The optical characteristics are measured under stable conditions at 25 °C (Room Temperature):

Item	Unit	Conditions	Min.	Typ.	Max.	Note
White Luminance (with TP)	[cd/m ²]	I _F = 40 mA	280	350	-	1
Uniformity	%	5 Points	75	80	-	1, 2, 3
Contrast Ratio			600	1000	-	4
Response Time	[msec]	Rising	-	13	23	5
		Falling	-	12	22	
		Rising + Falling	-	25	45	
Viewing Angle	[degree]	Horizontal (Right) CR = 10 (Left)	75	89	-	6
	[degree]		75	89	-	
	[degree]	Vertical (Upper) CR = 10 (Lower)	75	89	-	
	[degree]		75	89	-	
Color / Chromaticity Coordinates (CIE 1931)		Red x	-0.05	TBD	+0.05	
		Red y		TBD		
		Green x		TBD		
		Green y		TBD		
		Blue x		TBD		
		Blue y		TBD		
		White x		0.313		
		White y		0.329		
Color Gamut	%			72	-	

Note 1: Measurement method

Equipment Pattern Generator, Power Supply, Digital Voltmeter, Luminance meter (SR_3 or equivalent)

Aperture 1° with 50cm viewing distance

Test Point Center

Environment < 1 lux

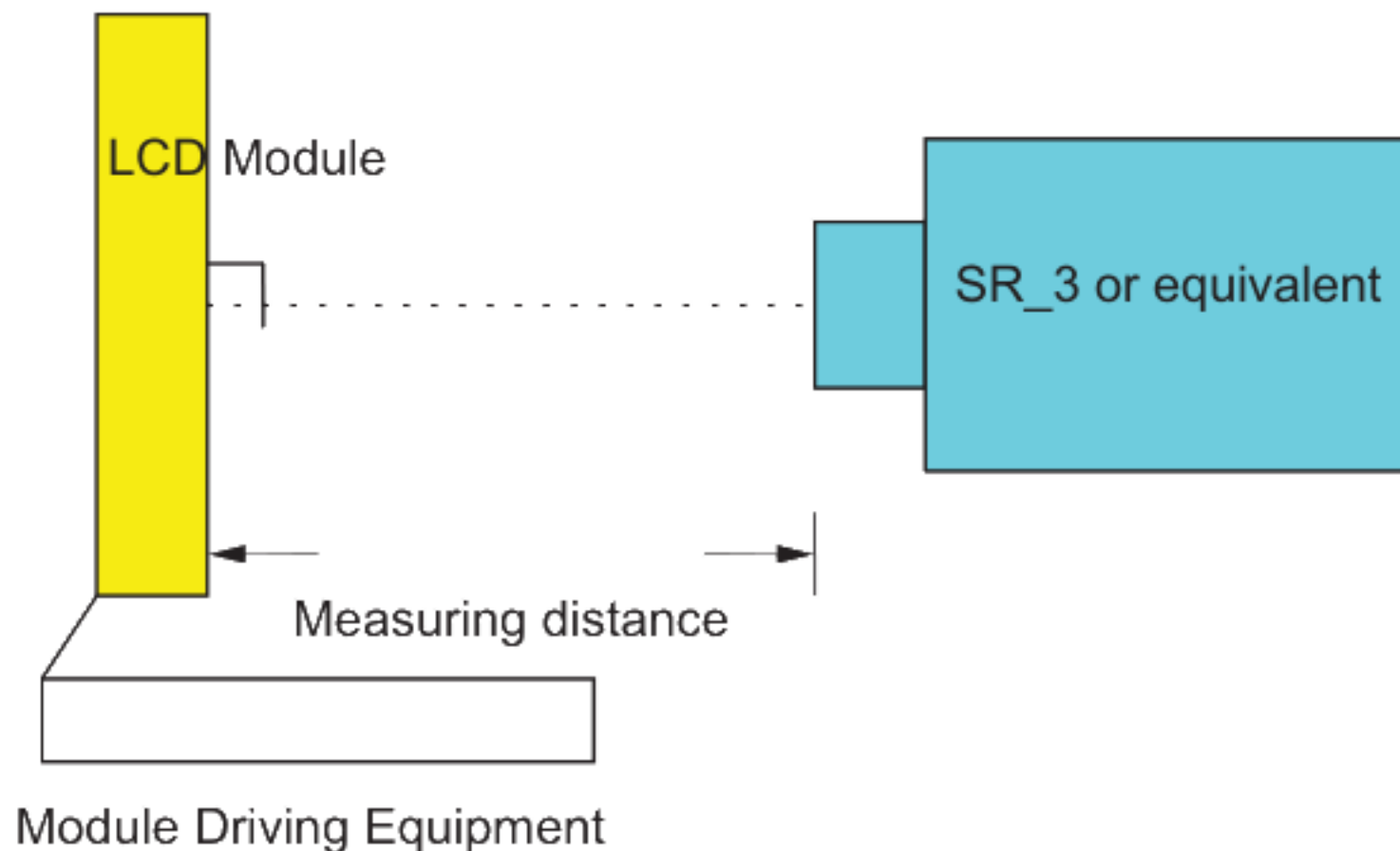

Note 2: Definition of 5 points position. Display active area

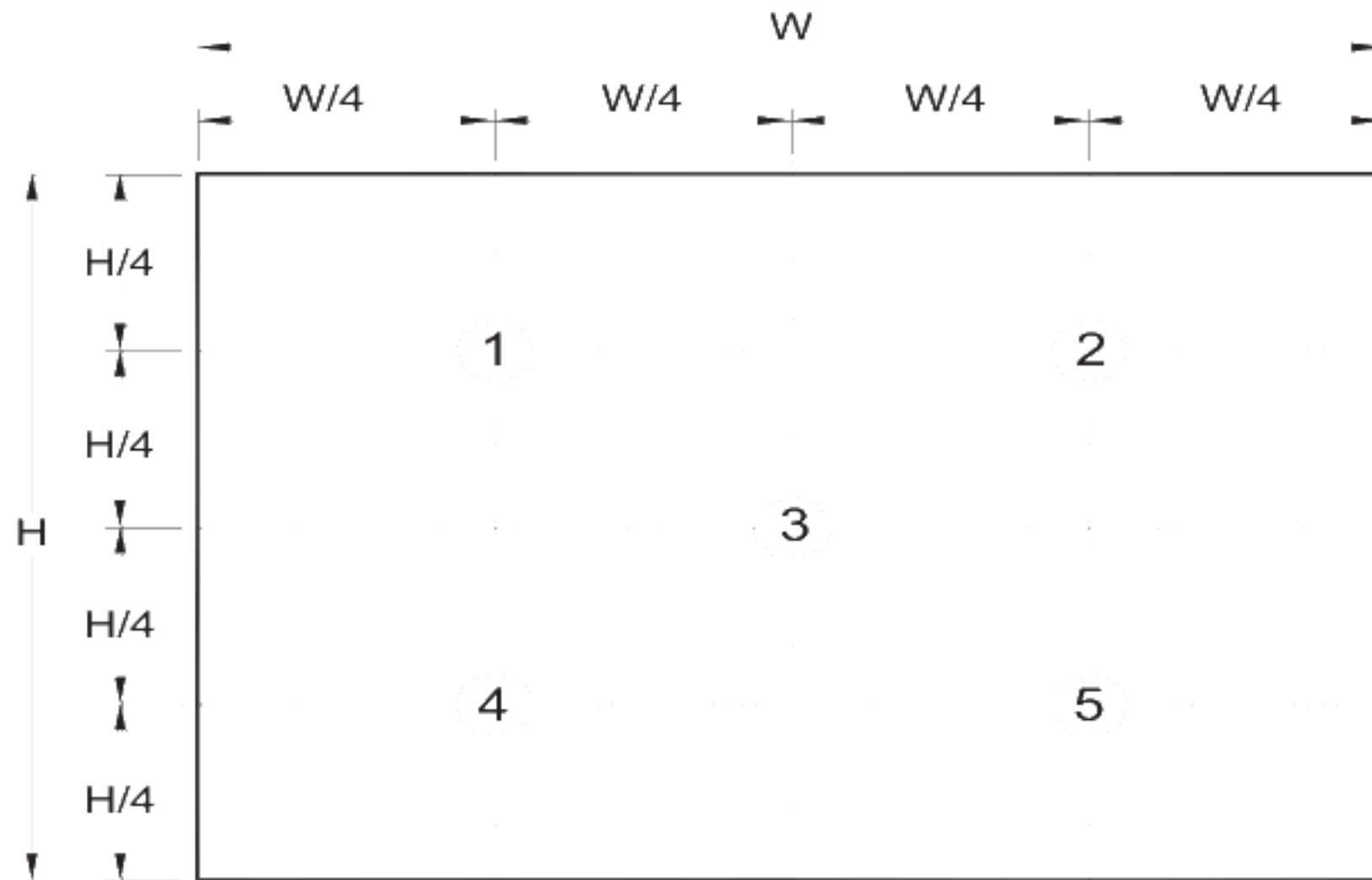

Note 3: The luminance uniformity of 5 points is defined by dividing the minimum luminance values by the maximum test point luminance

$$\delta_{w5} = \frac{\text{Minimum Brightness of five points}}{\text{Maximum Brightness of five points}}$$

Note 4: Definition of contrast ratio (CR):

$$\text{Contrast ratio (CR)} = \frac{\text{Brightness on the "White" state}}{\text{Brightness on the "Black" state}}$$

Note 5: Definition of response time:

The output signals of photo detector are measured when the input signals are changed from "White" to "Black" (falling time) and from "Black" to "White" (rising time), respectively. The response time interval is between 10% and 90% of amplitudes. Please refer to the figure as below.

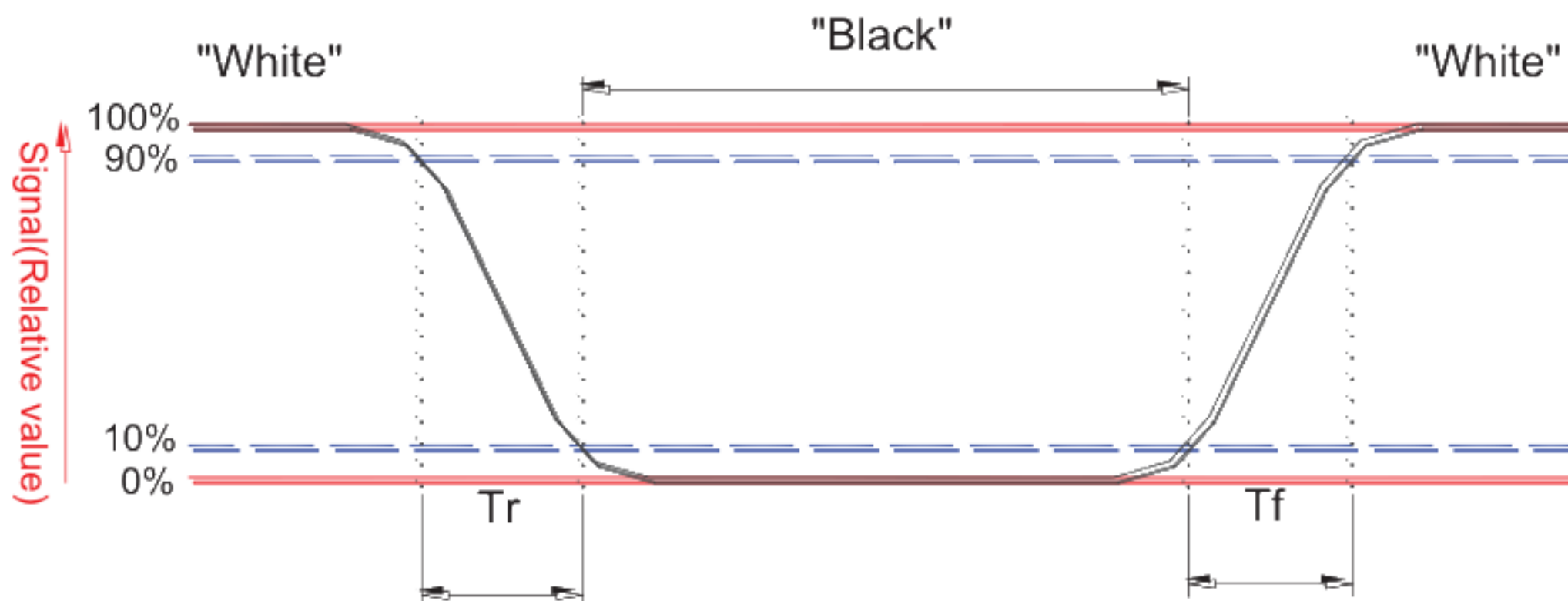

Note 6: Definition of viewing angle

Viewing angle is the measurement of contrast ratio ≥ 10 , at the screen center, over a 180° horizontal and 180°

vertical range (off-normal viewing angles). The 180° viewing angle range is broken down as below: 90° (θ) horizontal left and right, and 90° (Φ) vertical high (up) and low (down). The measurement direction is typically perpendicular to the display surface with the screen rotated to its center to develop the desired measurement viewing angle.

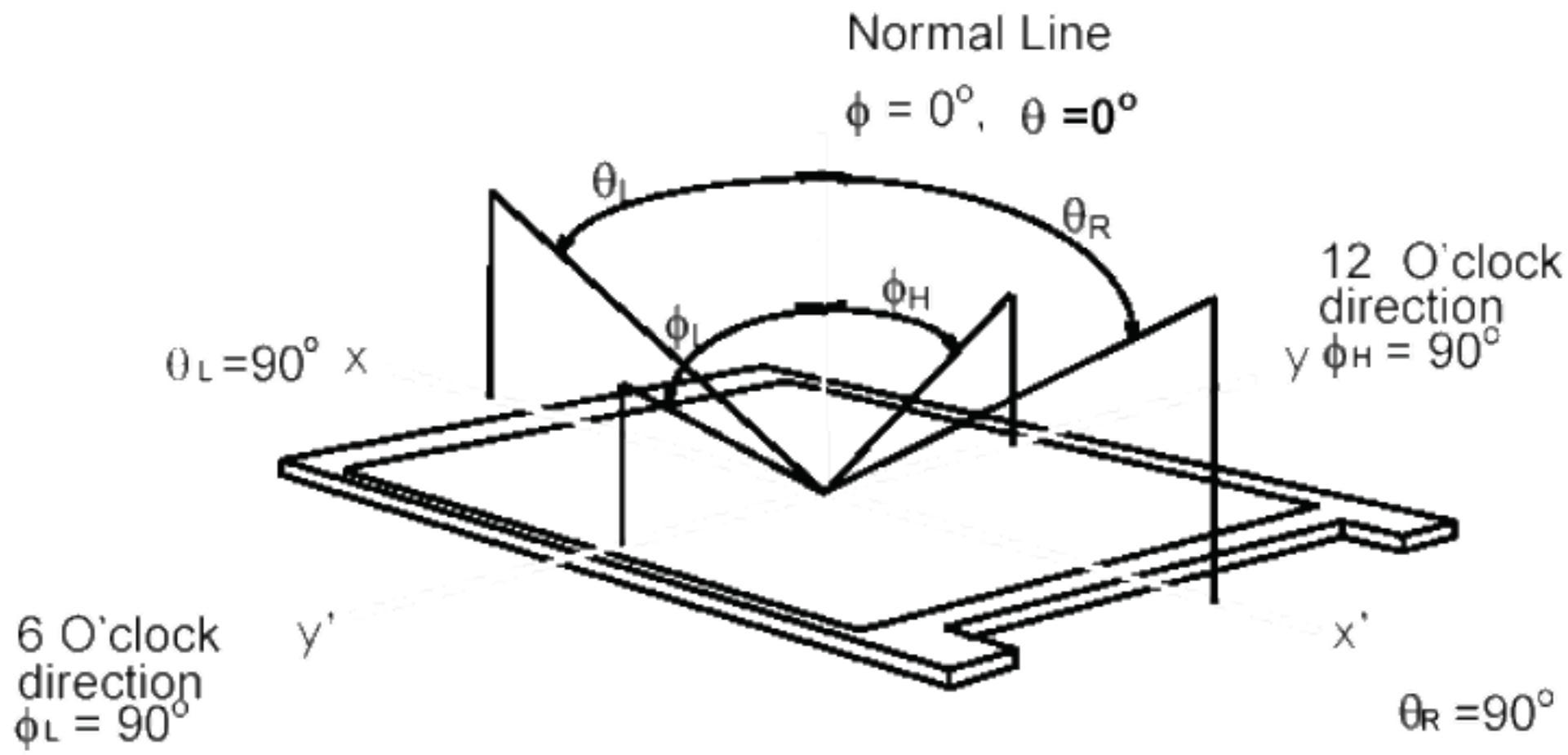

AUO Confidential for Hang

3. Functional Block Diagram

The following diagram shows the functional block of the 17.0 inch color TFT/LCD module:

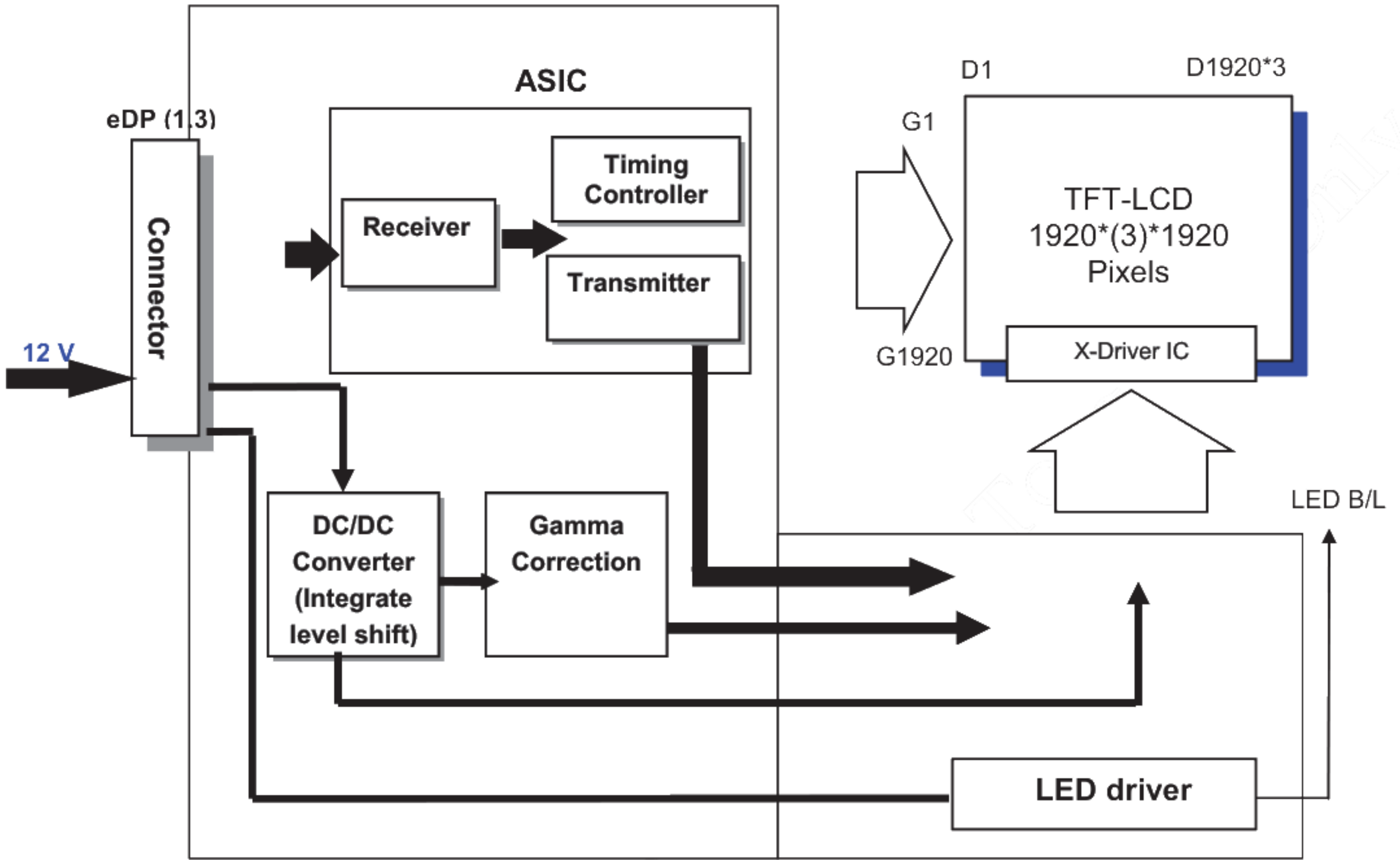

4. Absolute Maximum Ratings

4.1 Absolute Ratings of TFT LCD Module

Item	Symbol	Min	Max	Unit
Logic/LCD drive Voltage	Vin	10.8	13.2	[Volt]

4.2 Touch Sensor

Item	Symbol	Min	Max	Unit	Conditions
Voltage from VCCIO to AGND and DGND	-	3.3	3.6	[Volt]	
Voltage from any pin to AGND and DGND	-	-0.3	3.6	[Volt]	

4.3 Absolute Ratings of Environment

Item	Symbol	Min	Max	Unit
Operating Temperature	TOP	-10	60	[°C]
Operation Humidity	HOP	5	90	[%RH]
Storage Temperature	TST	-20	70	[°C]
Storage Humidity	HST	5	90	[%RH]

Note 1: With in Ta (25°C)

Note 2: Permanent damage to the device may occur if exceeding maximum values

Note 3: Temperature and relative humidity range are shown as following.

1. 95% RH Max (Ta ≤ 39 °C)
2. Max wet-bulb temperature at 39°C or less. (Ta ≤ 39 °C)
3. No condensation

Note 4: Function Judged only

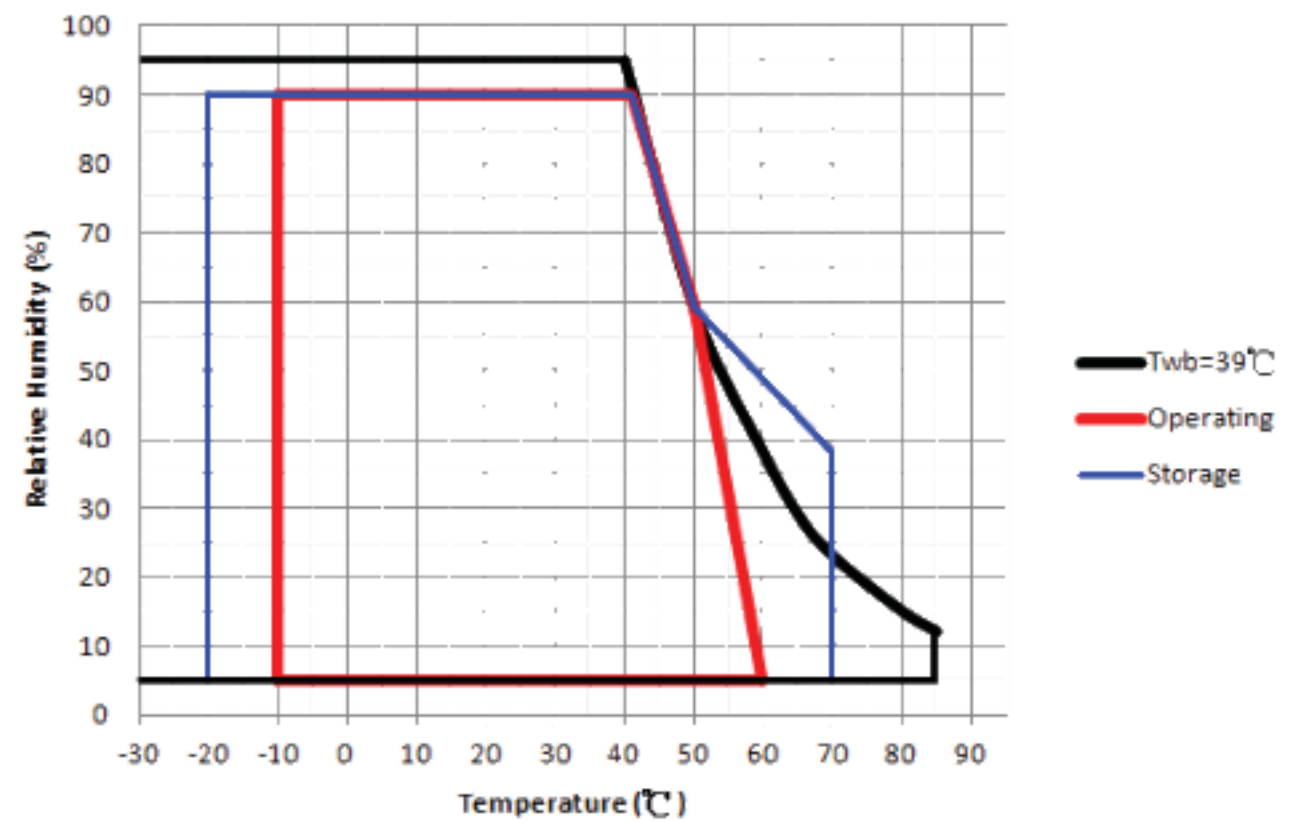

Operation Range Storage Range +

5. Electrical Characteristics

5.1 TFT LCD Module and Backlight Unit

5.1.1 Power Specification

Following characteristics are measured under stable condition at 25°C (Room Temperature).

Symbol	Parameter	Min	Typ	Max	Units	Remark
VDD	Input Voltage	10.8	12	13.2	Volt	
IDD	Input Current	-	1.12	-	A	VDD=12V, All White Pattern AT 60Hz
PDD	Power Consumption		13.5	16.5	Watt	VDD=12V, All White Pattern AT 60Hz
Irush	Inrush Current	-	-	3	A	Note 4
BL_EN	On Control Voltage	1.8	-	-	Volt	
	Off Control Voltage	-	-	0.6	Volt	
PWM	PWM Dimming Frequency	10K	-	20K	Hz	
	Swing Voltage	3	3.3	3.6	Volt	
	Dimming Duty Cycle	5	-	100	%	
I _F	LED Forward Current		40		mA	Ta = 25°C
LTLED	LED Life Time	50,000	-	-	Hrs	Note 4

Note 1: Ta means ambient temperature of TFT-LCD module,

Note 2: If module is driven by high current or at high ambient temperature & humidity condition. The operating life will be reduced.

Note 3: LED light bar structure: (6 strings x 9 pcs / string =54 pcs LED)

Note 4: Definition of life time: Brightness becomes to 50% of its original value. The minimum life time of LED unit is on the condition of I_F = 40 mA and 25±2°C (Room Temperature).

Note 5: Measurement condition:

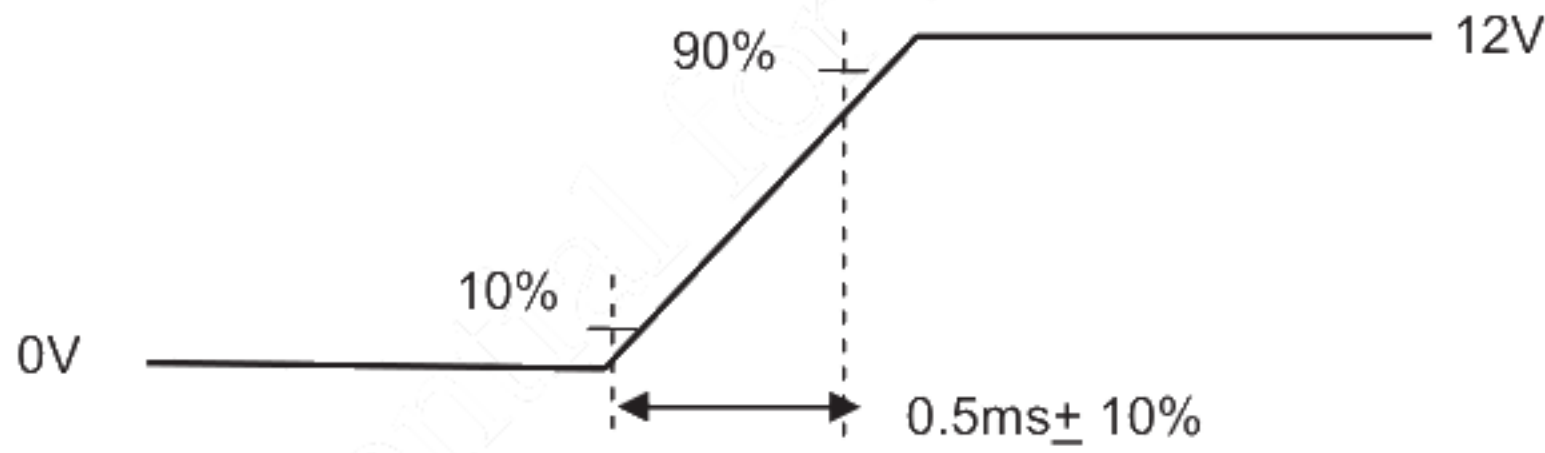
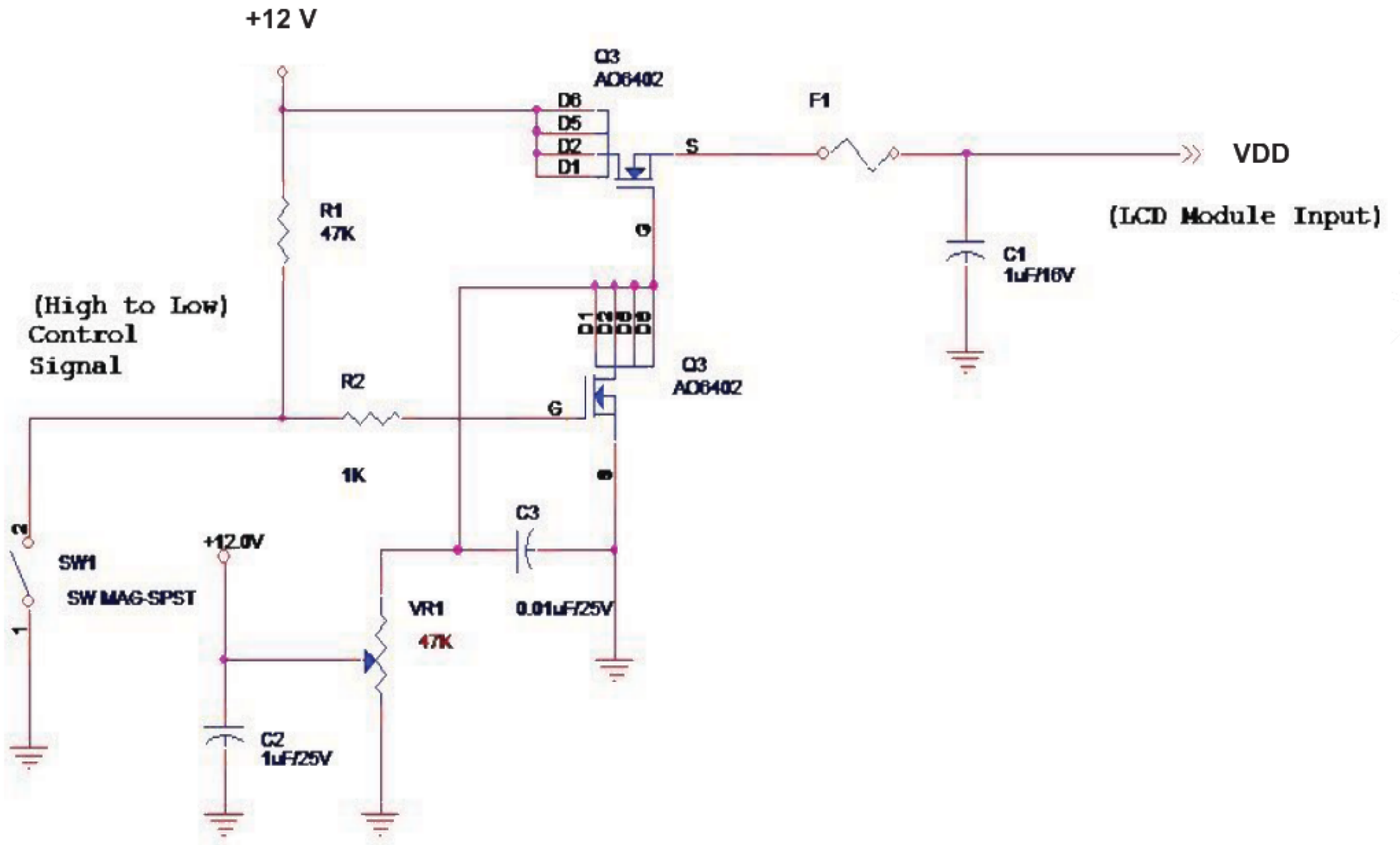

VDD rising time

5.1.2 Signal Electrical Characteristics

Input signals shall be low or High-impedance state when VDD is off. Signal electrical characteristics are as follows;

Display Port main link signal:

Differential pair VD+ , VD-
Which is one Display port
Main link

VCM of Display port
Main link

$$V_{diff_{P-P}} = [(VD+) - (VD-)] \times 2$$

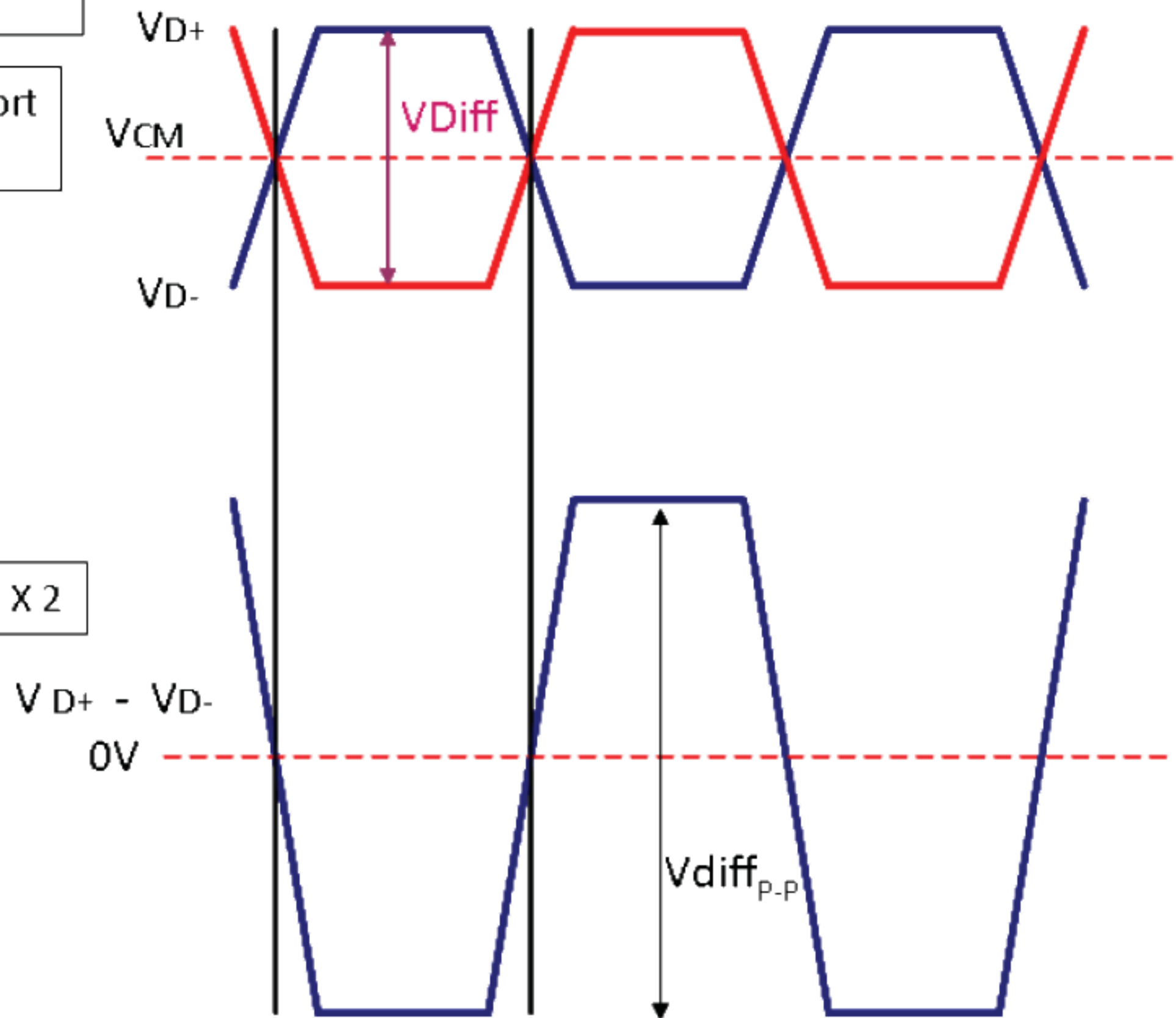

Display port main link					
		Min	Typ	Max	unit
VCM	RX input DC Common Mode Voltage		0		V
VDiff _{P-P}	Peak-to-peak Voltage at a receiving Device	120		1320	mV

Follow as VESA display port standard V1.1a.

Display Port AUX_CH signal:

Differential AUX+ , AUX-
Which is Display port AUX_CH

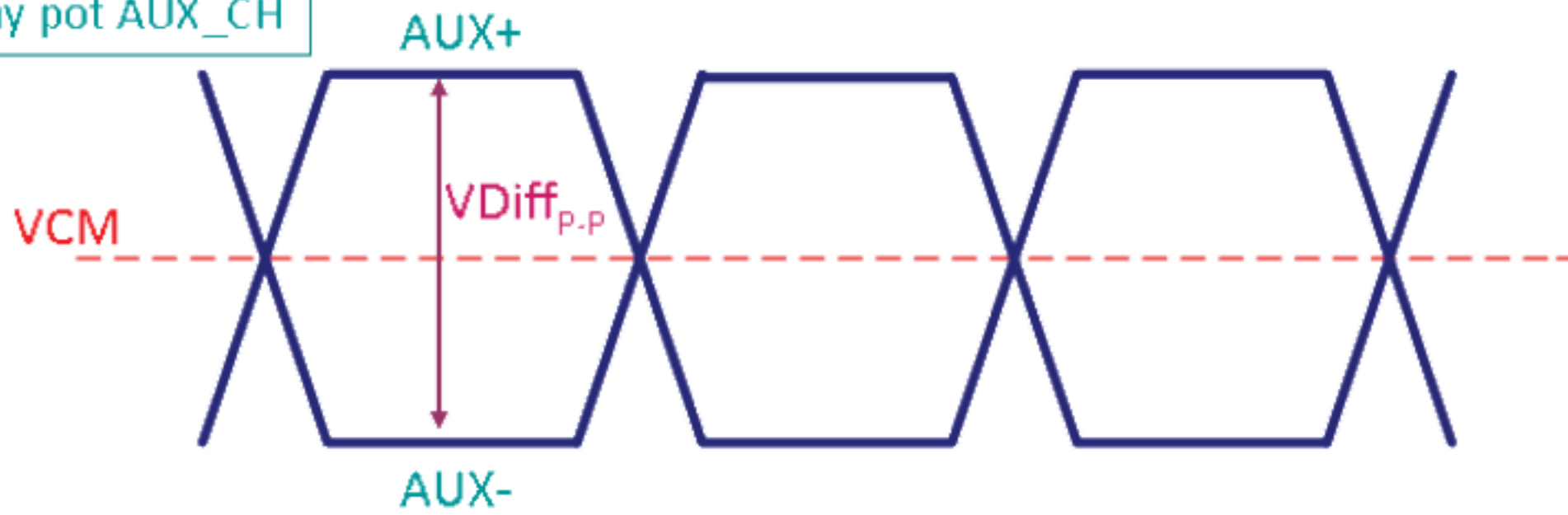

Display port AUX_CH					
		Min	Typ	Max	unit
VCM	AUX DC Common Mode Voltage		0		V
VDiff _{p.p}	AUX Peak-to-peak Voltage at a receiving Device	0.4	0.6	0.8	V

Follow as VESA display port standard V1.1a.

Display Port VHPD signal:

Display Port VHPD					
		Min	Typ	Max	unit
VHPD	HPD voltage	2.25		3.6	V

Follow as VESA display port standard V1.1a.

6. Signal Characteristic

6.1 Pixel Format Image

Following figure shows the relationship between input signal and LCD pixel format.

	1			2								1919			1920		
1st Line	R	G	B	R	G	B						R	G	B	R	G	B

1920 Line	R	G	B	R	G	B						R	G	B	R	G	B

6.2 Scanning Direction

The following figures show the image seen from the front view. The arrow indicates the direction of scan.



Fig. 1 Normal scan (Pin4, DPS = Low or NC)

6.3 Signal Description

The module uses a LVDS receiver embedded in AUO's ASIC. LVDS is a differential signal technology for LCD interface and a high-speed data transfer device.

PIN #	SIGNAL NAME	DESCRIPTION
1	NC	NC
2	GND	Ground
3	Lane3_N	Signal Link Lane 3_N
4	Lane3_P	Signal Link Lane 3_P
5	GND	Ground
6	Lane2_N	Signal Link Lane 2_N
7	Lane2_P	Signal Link Lane 2_P
8	GND	Ground
9	Lane1_N	Signal Link Lane 1_N
10	Lane1_P	Signal Link Lane 1_P
11	GND	Ground
12	Lane0_N	Signal Link Lane 0_N
13	Lane0_P	Signal Link Lane 0_P
14	GND	Ground
15	AUX_CH_P	Signal Auxiliary Channel P
16	AUX_CH_N	Signal Auxiliary Channel N
17	GND	Ground
18	NC	NC
19	NC	NC
20	NC	NC
21	NC	NC
22	BIST	BIST
23	GND	Ground
24	GND	Ground
25	GND	Ground
26	GND	Ground
27	HPD	HPD signal pin
28	GND	Ground
29	GND	Ground
30	GND	Ground
31	GND	Ground
32	LED_EN	Backlight ON/OFF
33	LED_PWM	System PWM signal input for dimming
34	NC-Reserved	Reserved for LCD manufacture's use(EDID_CLK)
35	NC-Reserved	Reserved for LCD manufacture's use(EDID_DATA)

36	VDD	LCD logic and Backlight power(+12V)
37	VDD	LCD logic and Backlight power(+12V)
38	VDD	LCD logic and Backlight power(+12V)
39	VDD	LCD logic and Backlight power(+12V)
40	NC	NC

Note: "Power Ground" stands for 0V.

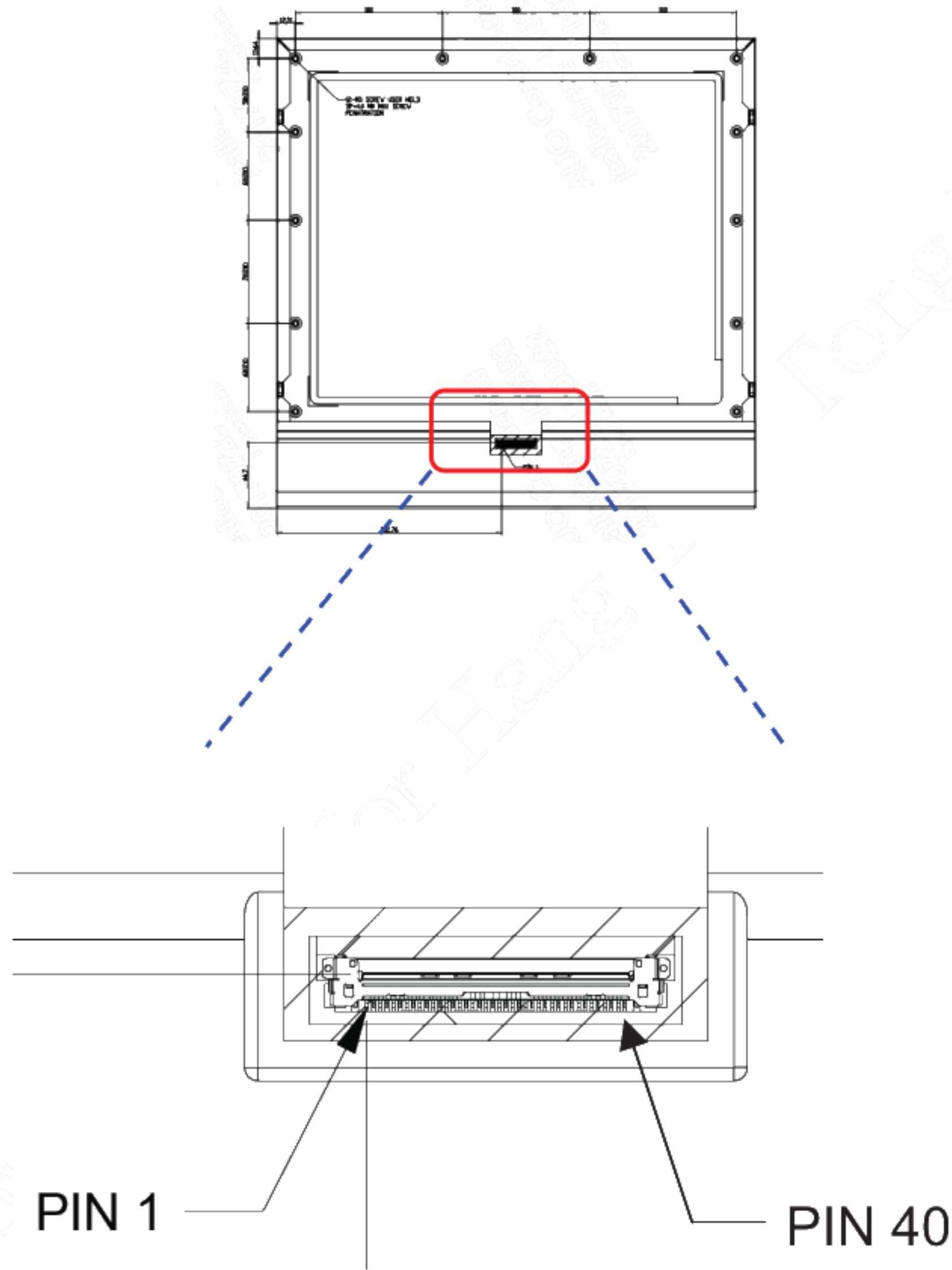

6.4 Interface Timing

6.4.1 Timing Characteristics

Signal	Symbol	Min.	Typ.	Max.	Unit
Clock Frequency	$1/T_{\text{Clock}}$	-	247	-	MHz
Vertical Section	Period	T_V	1969	-	T_{Line}
	Active	T_{VD}	1920	-	
	Blanking	T_{VB}	49	-	
Horizontal Section	Period	T_H	2104	-	T_{Clock}
	Active	T_{HD}	1920	-	
	Blanking	T_{HB}	184	-	
Frame Rate	F	59	60	61	Hz

Note : DE mode only.

6.4.2 Input Timing Diagram

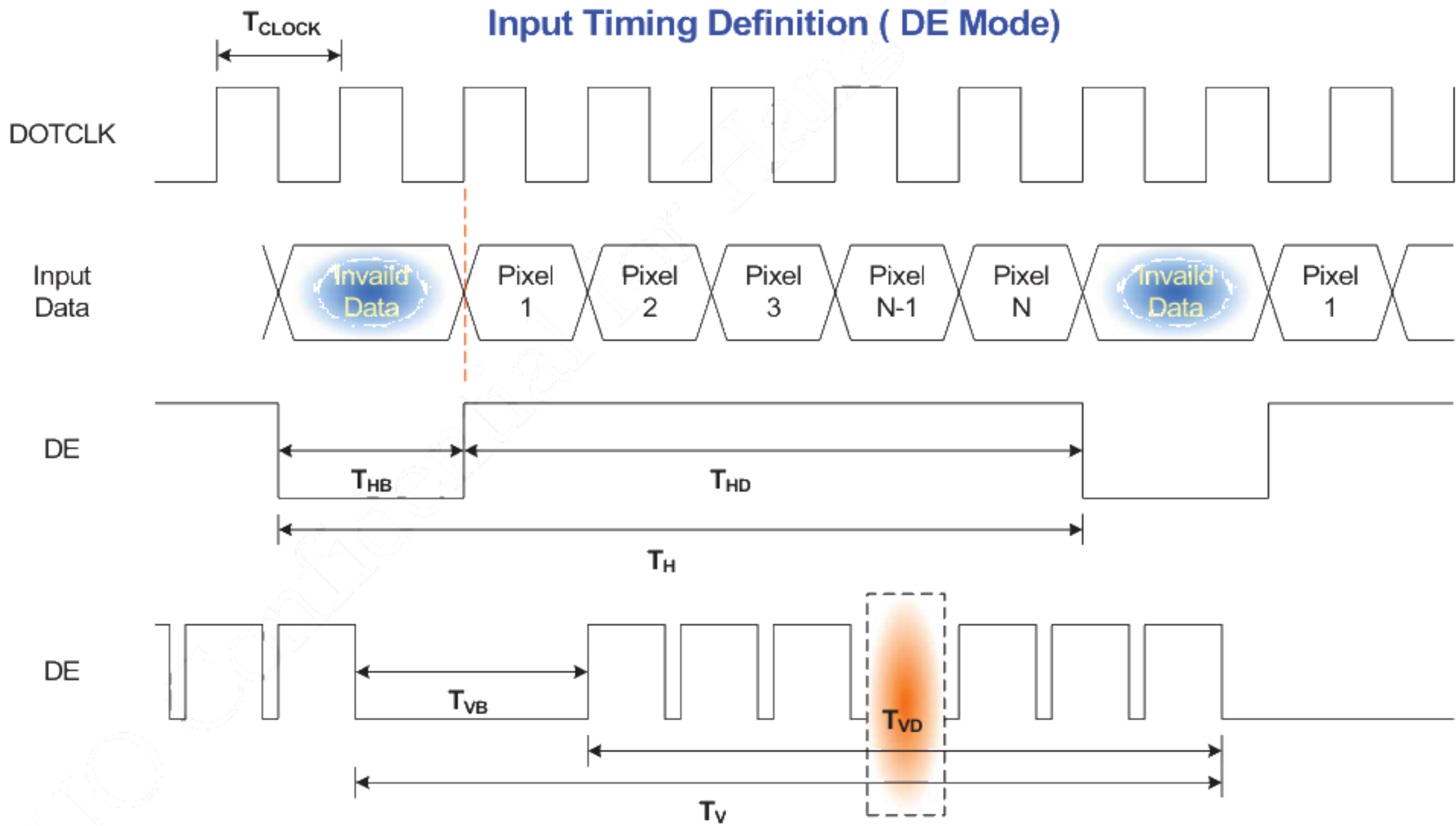

6.5 Power ON/OFF Sequence

VDD power and lamp on/off sequence is as below. Interface signals are also shown in the chart. Signals from any system shall be Hi-Z state or low level when VDD is off.

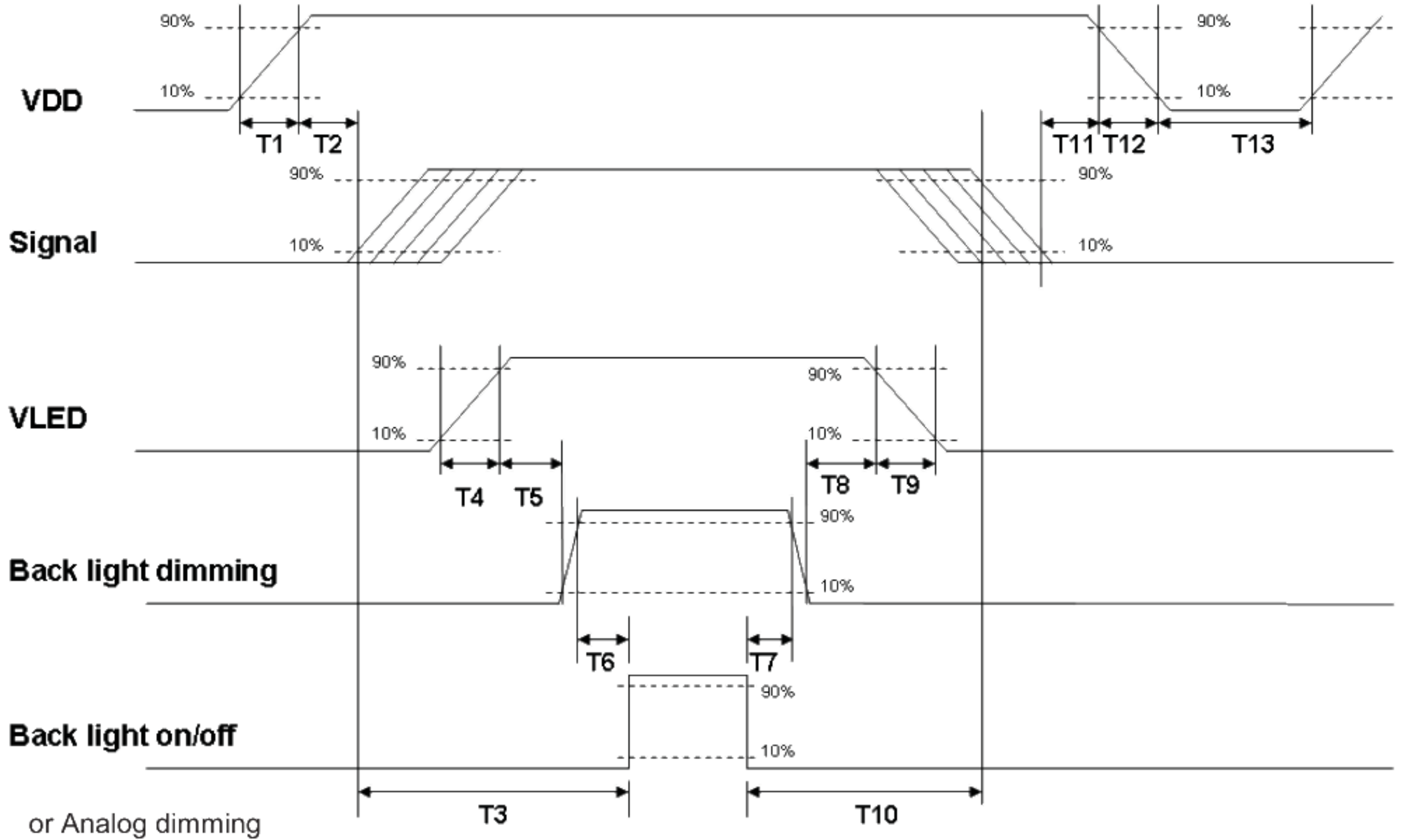

Power ON/OFF sequence timing

Parameter	Value			Units
	Min.	Typ.	Max.	
T1	0.5	-	10	[ms]
T2	30	40	50	[ms]
T3	200	-	-	[ms]
T6	10	-	-	[ms]
T7	0	-	-	[ms]
T10	110	-	-	[ms]
T11	0	16	50	[ms]
T12	0	-	10	[ms]
T13	1000	-	-	[ms]

The above on/off sequence should be applied to avoid abnormal function in the display. Please make sure to turn off the power when you plug the cable into the input connector or pull the cable out of the connector.

7. Connector & Pin Assignment

Physical interface is described as for the connector on module. These connectors are capable of accommodating the following signals and will be following components.

7.1 TFT LCD Module: eDP Connector

Connector Name / Designation	Interface Connector / Interface card
Manufacturer	I-PEX or compatible
Type Part Number	20455-040E-76B or equivalent.
Mating Housing Part Number	20453-240T-11 or compatible

8. Reliability Test Criteria

Items	Required Condition	Note
Temperature Humidity Bias	Ta= 50°C , 80%RH, 300hours	
High Temperature Operation	Ta= 60°C , 300hours	
Low Temperature Operation	Ta= -10°C , 300hours	
Hot Storage	Ta= 70°C , 300hours	
Cold Storage	Ta= -20°C , 300hours	
Thermal Shock Test	-20 °C /30 min ,60 °C /30 min ,100cycles	
Shock Test (Non-Operating)	Acceleration: 50 G Wave: Half-sine Active Time: 20 ms Direction: ±X, ±Y, ±Z (one time for each Axis)	
Vibration Test (Non-Operating)	Acceleration: 1.5 Grms Wave: Random Frequency: 10 - 200 Hz Duration: 30 Minutes each Axis (X, Y, Z)	
On/off test	On/10 sec, Off/10 sec, 30,000 cycles	
ESD	Contact Discharge: ± 8 KV, 150pF(330Ω) 1sec, 8 points, 25 times/ point., Class B	1
	Air Discharge: ± 15 KV, 150pF(330Ω) 1sec, 8 points, 25 times/ point., Class B	

Note 1: According to EN61000-4-2, ESD class B: Some performance degradation allowed. No data lost
Self-recoverable. No hardware failures.

Note2:

- Water condensation is not allowed for each test items.
- Each test is done by new TFT-LCD module. Don't use the same TFT-LCD module repeatedly for reliability test.
- The reliability test is performed only to examine the TFT-LCD module capability.
- To inspect TFT-LCD module after reliability test, please store it at room temperature and room humidity for 24 hours at least in advance.
- No function failure occurs.

10. Label and Packaging

10.1 Shipping Label (on the rear side of TFT-LCD display)

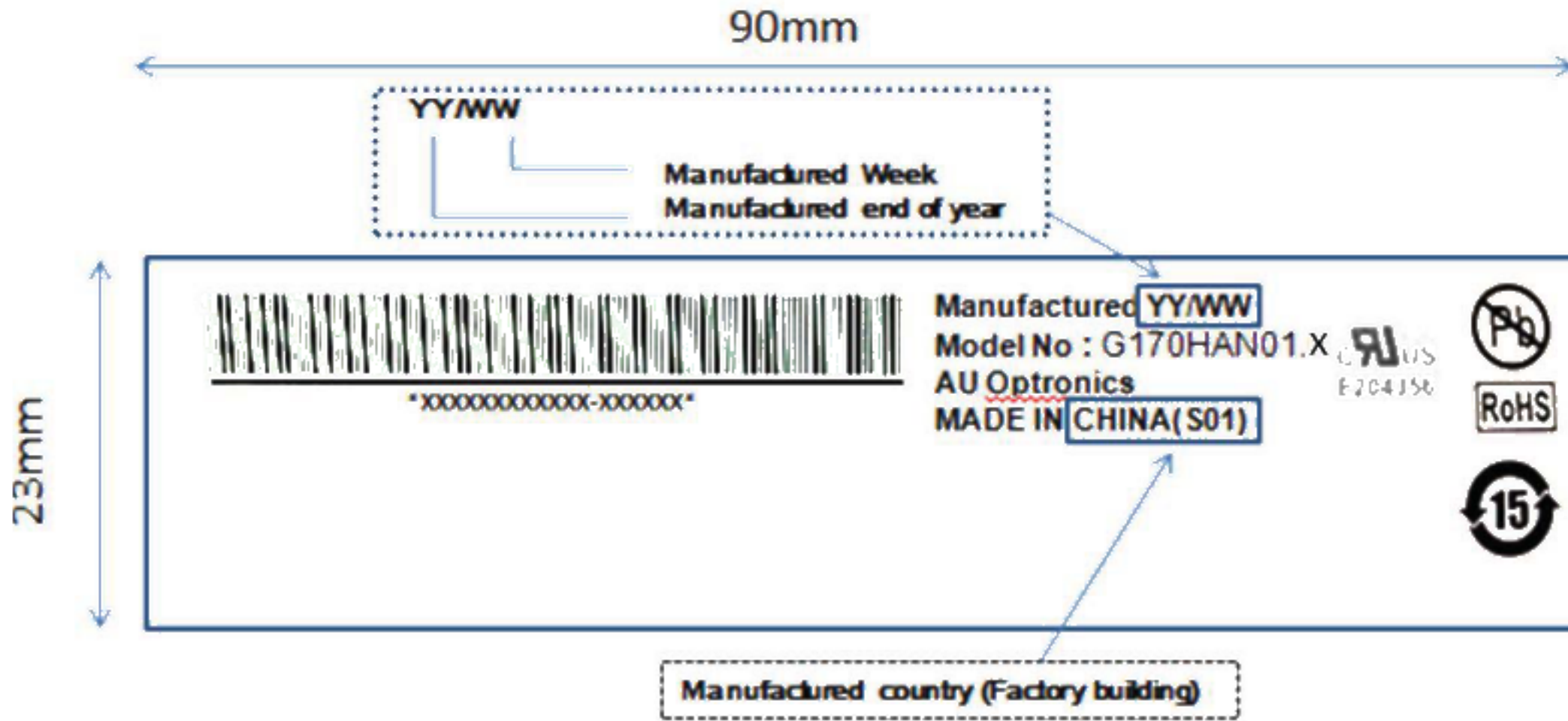

10.2 Carton Package

- Max capacity : 8 TFT-LCD module per carton
- Max weight: 18 kg per carton
- Outside dimension of carton: 523mm(L)* 483mm(W)*277mm(H)
- Pallet size : 1150 mm * 980mm * 132mm

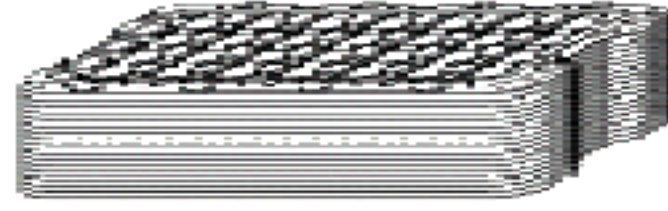

Cover with the empty PET tray, the whole package includes (4+1) PET trays. The even layers should be turned 180°

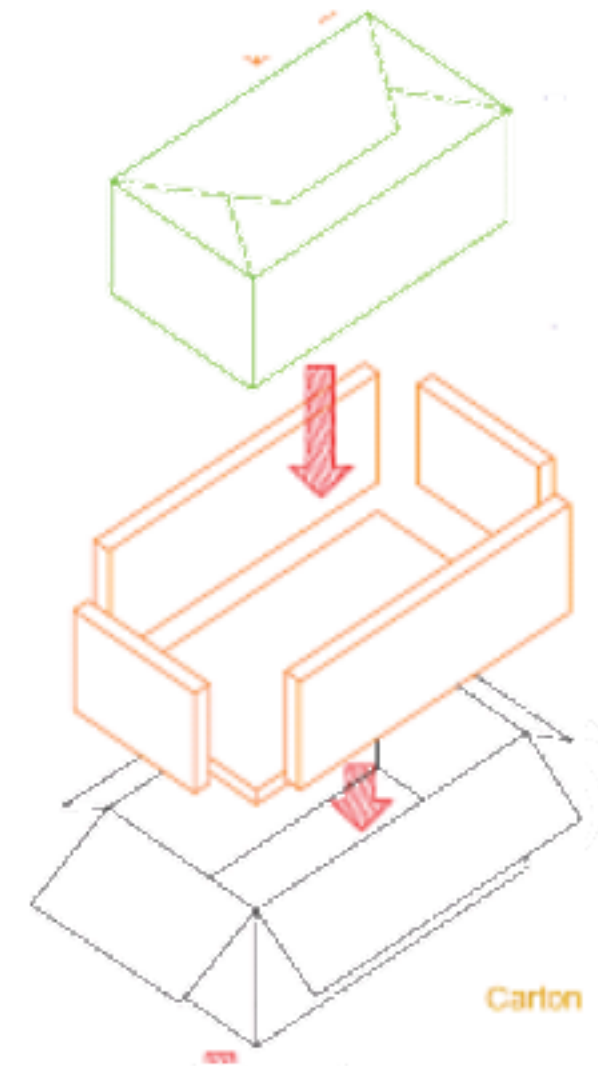
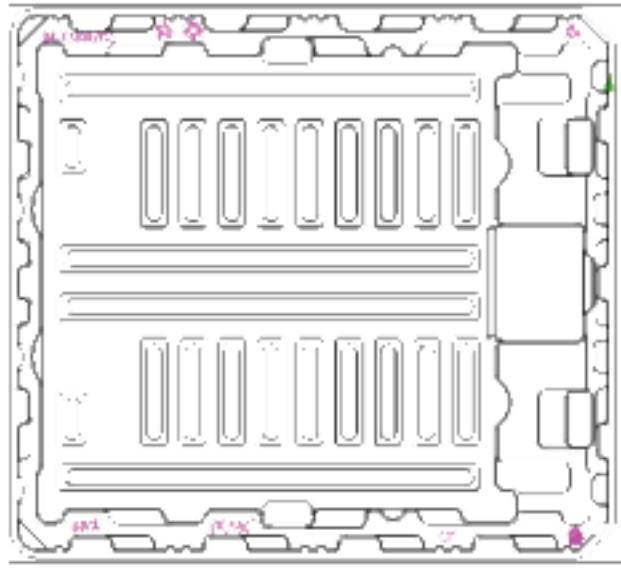

Place the round EPE and the first package

Place dummy tray

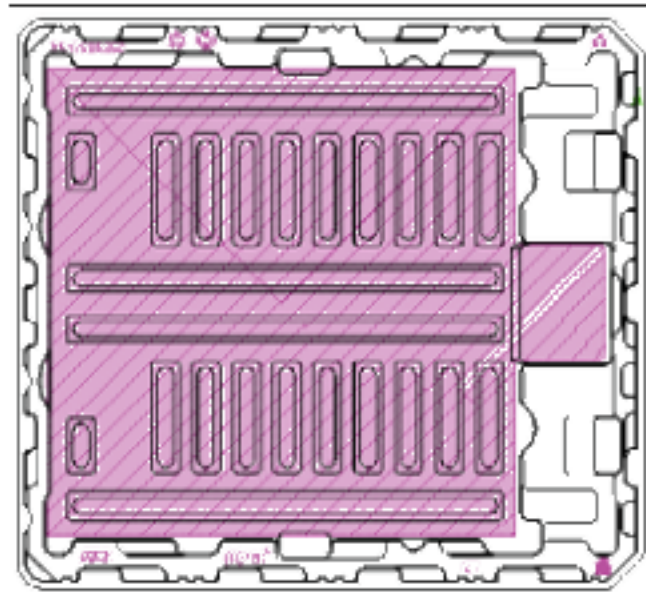

Insert the package from the sideways of the Antistatic Bag.
Pack the bag, and then tape with scotch tape.

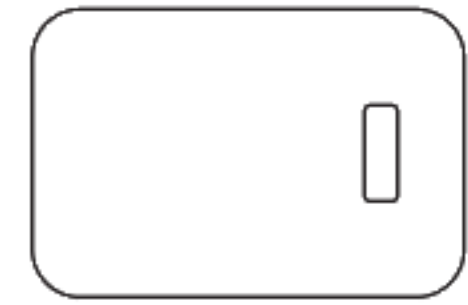

Put 1pcs paper between two packages

Put 1pcs EPE into tray

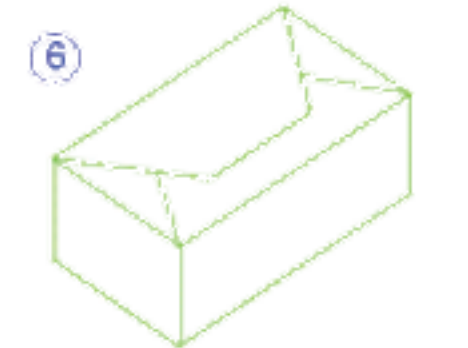
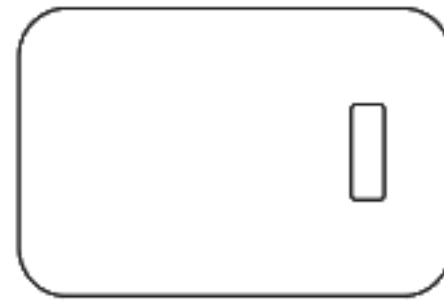
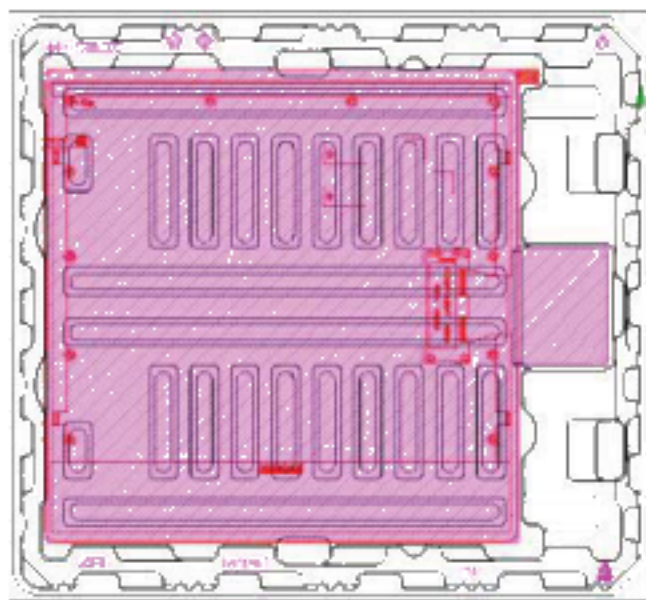

Place the second package, Cover the top EPE

Put 1pcs module on EPE, TP is face down

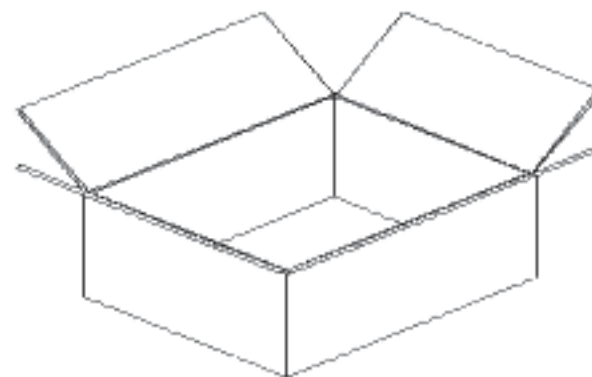
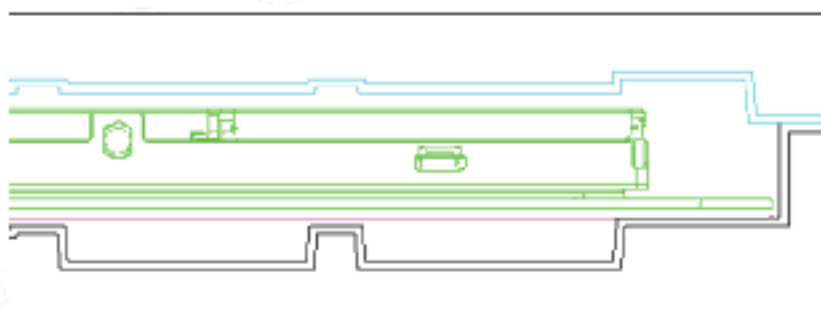

Place the EPE and Paper into carton

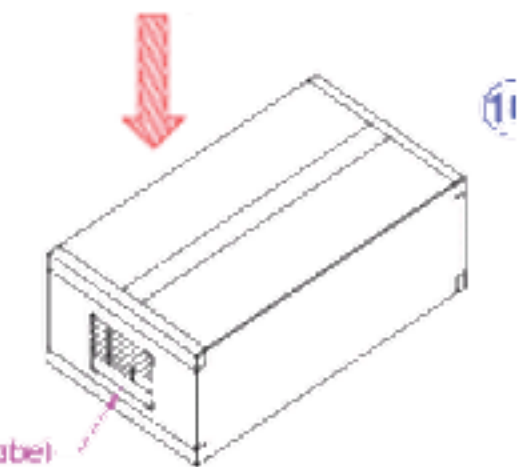

Seal the carton with packing tape

1 tray contains 1pcs module and 1pcs EPE

11 Safety

11.1 Sharp Edge Requirements

There will be no sharp edges or comers on the display assembly that could cause injury.

11.2 Materials

11.2.1 Toxicity

There will be no carcinogenic materials used anywhere in the display module. If toxic materials are used, they will be reviewed and approved by the responsible AUO toxicologist.

11.2.2 Flammability

All components including electrical components that do not meet the flammability grade UL94-V1 in the module will complete the flammability rating exception approval process.

The printed circuit board will be made from material rated 94-V1 or better. The actual UL flammability rating will be printed on the printed circuit board.

11.3 Capacitors

If any polarized capacitors are used in the display assembly, provisions will be made to keep them from being inserted backwards.

11.4 National Test Lab Requirement

The display module will satisfy all requirements for compliance to:

UL 60950-1, Second Edition

U.S.A. Information Technology Equipment