

Contents

1. Operating Precautions	4
2. General Description	5
2.1 Display Characteristics	5
2.2 Optical Characteristics	6
3. Functional Block Diagram	9
4. Absolute Maximum Ratings.....	10
4.1 Absolute Ratings of TFT LCD Module.....	10
4.2 Absolute Ratings of Environment.....	10
5. Electrical Characteristics.....	11
5.1 TFT LCD Module	11
5.2 Backlight Unit.....	13
6. Signal Characteristic.....	14
6.1 Pixel Format Image.....	14
6.2 Scanning Direction.....	14
6.3 Signal Description	15
6.4 The Input Data Format.....	16
6.5 Interface Timing	17
6.6 Power ON/OFF Sequence	18
7. Connector & Pin Assignment	19
7.1 TFT LCD Module: LVDS Connector.....	19
7.2 Backlight Unit: LED Driver Connector.....	21
7.3 LED Connector Pin Assignment.....	21
9. Mechanical Characteristics	23
9.1 LCM Outline Dimension (Front View and back view).....	23
10. Label and Packaging.....	24
10.1 Shipping Label (on the rear side of TFT-LCD display).....	24
10.2 Carton Package	24
11 Safety.....	25
11.1 Sharp Edge Requirements	25
11.2 Materials.....	25
11.3 Capacitors	25
11.4 National Test Lab Requirement.....	25

1. Operating Precautions

- 1) Since front polarizer is easily damaged, please be cautious and not to scratch it.
- 2) Be sure to turn off power supply when inserting or disconnecting from input connector.
- 3) Wipe off water drop immediately. Long contact with water may cause discoloration or spots.
- 4) When the panel surface is soiled, wipe it with absorbent cotton or soft cloth.
- 5) Since the panel is made of glass, it may be broken or cracked if dropped or bumped on hard surface.
- 6) Since CMOS LSI is used in this module, take care of static electricity and insure human earth when handling.
- 7) Do not open nor modify the module assembly.
- 8) Do not press the reflector sheet at the back of the module to any direction.
- 9) In case if a module has to be put back into the packing container slot after it was taken out from the container, do not press the center of the LED Reflector edge. Instead, press at the far ends of the LED Reflector edge softly. Otherwise the TFT Module may be damaged.
- 10) At the insertion or removal of the Signal Interface Connector, be sure not to rotate nor tilt the Interface Connector of the TFT Module.
- 11) TFT-LCD Module is not allowed to be twisted & bent even force is added on module in a very short time. Please design your display product well to avoid external force applying to module by end-user directly.
- 12) Small amount of materials without flammability grade are used in the TFT-LCD module. The TFT-LCD module should be supplied by power complied with requirements of Limited Power Source (IEC60950-1 or UL60950-1), or be applied exemption.
- 13) Severe temperature condition may result in different luminance, response time.
- 14) Continuous operating TFT-LCD Module under high temperature environment may accelerate LED light bar exhaustion and reduce luminance dramatically.
- 15) The data on this specification sheet is applicable when TFT-LCD module is placed in landscape position.
- 16) Continuous displaying fixed pattern may induce image sticking. It's recommended to use screen saver or moving content periodically if fixed pattern is displayed on the screen.

2. General Description

G150XTN06.0 is a Color Active Matrix Liquid Crystal Display composed of a TFT-LCD display, a driver circuit, and a backlight system. The screen format is intended to support XGA (1024(H) x 768(V)) screen and 16.2M or 262K colors. All input signals are LVDS interface compatible. All design rules of this module can correspond to PSWG standard.

G150XTN06.0 is designed for industrial display applications.

2.1 Display Characteristics

The following items are characteristics summary on the table under 25 °C condition:

Items	Unit	Specifications
Screen Diagonal	[inch]	15
Active Area	[mm]	304.128(H) x 228.096(V)
Pixels H x V		1024x3(RGB) x 768
Pixel Pitch	[mm]	0.297 x 0.297
Pixel Arrangement		R.G.B. Vertical Stripe
Display Mode		TN, Normally White
Nominal Input Voltage VDD	[Volt]	3.3 typ.
Typical Power Consumption	[Watt]	8.92W
Weight	[Grams]	1000g (max.)
Physical Size	[mm]	326.5(H)x 253.5(V) x 12.0(D) (max.)
Electrical Interface		LVDS
Surface Treatment		Anti-glare
Support Color		16.2M/262K
Temperature Range Operating Storage (Non-Operating)	[°C] [°C]	-30 to +85 -30 to +85
RoHS Compliance		RoHS Compliance
Light Bar Unit		LED, Replaceable

2.2 Optical Characteristics

The optical characteristics are measured under stable conditions at 25°C (Room Temperature):

Item	Unit	Conditions	Min.	Typ.	Max.	Note
White Luminance	[cd/m ²]		320	400	-	1
Uniformity	%	9 Points	75	80	-	1, 2, 3
Contrast Ratio			400	800	-	4
Cross talk	%		-	1.2	1.5	5
Response Time	[msec]	Rising	-	5.7		6
	[msec]	Falling	-	2.3		
	[msec]	Raising + Falling	-	8		
Viewing Angle	[degree]	Horizontal (Right) CR = 10 (Left)	70	80	-	7
	[degree]		70	80	-	
	[degree]	Vertical (Upper) CR = 10 (Lower)	60	70	-	
	[degree]		70	80	-	
Color / Chromaticity Coordinates (CIE 1931)		Red x	0.567	0.617	0.667	
		Red y	0.296	0.346	0.396	
		Green x	0.286	0.336	0.386	
		Green y	0.562	0.612	0.662	
		Blue x	0.109	0.159	0.209	
		Blue y	0.015	0.065	0.115	
		White x	0.261	0.311	0.361	
		White y	0.272	0.322	0.372	
Color Gamut	%			60	-	

Note 1: Measurement method

Equipment Pattern Generator, Power Supply, Digital Voltmeter, Luminance meter (SR_3 or equivalent)

Aperture 1° with 50cm viewing distance

Test Point Center

Environment < 1 lux

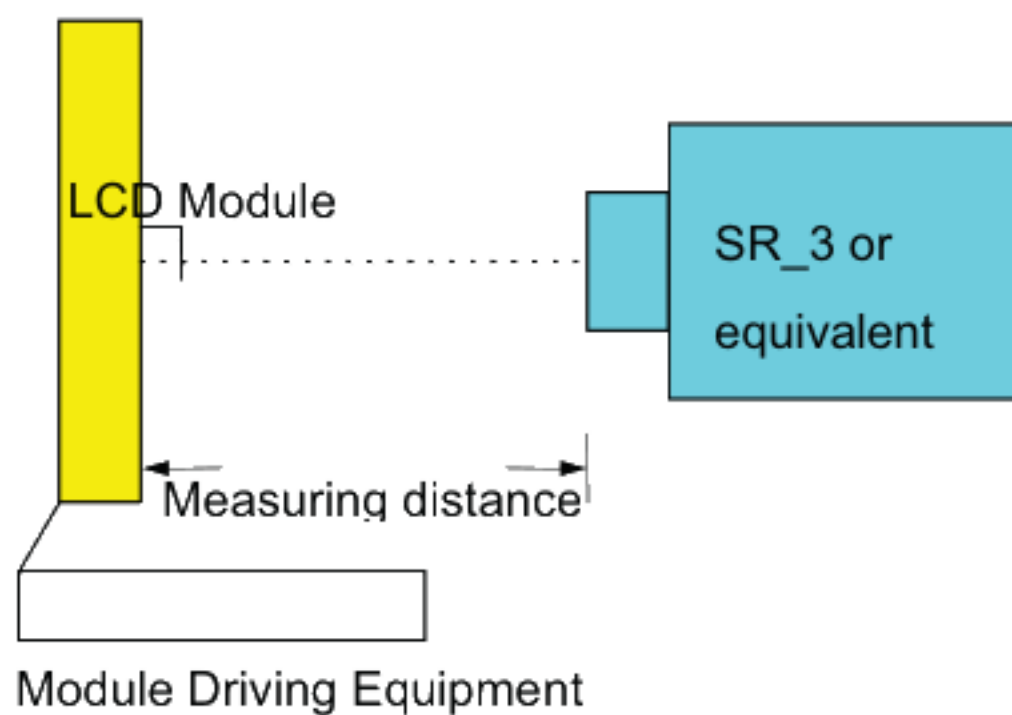

Note 2: Definition of 9 points position (Display active area : 304.128(H) x 228.096(V))

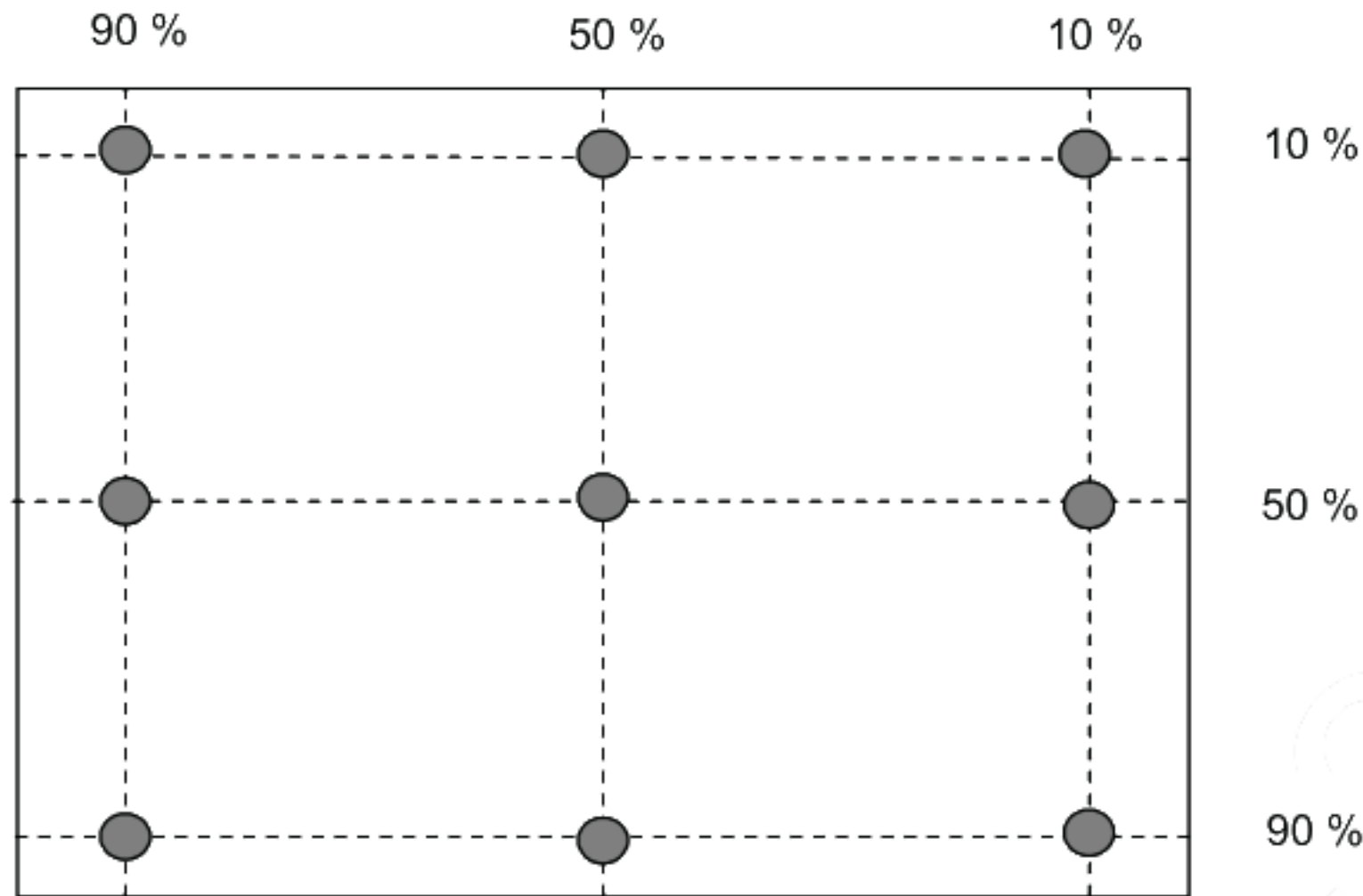

Note 3: The luminance uniformity of 9 points is defined by dividing the minimum luminance values by the maximum test point luminance

$$\delta_{w9} = \frac{\text{Minimum Brightness of nine points}}{\text{Maximum Brightness of nine points}}$$

Note 4 : Definition of contrast ratio (CR):

$$\text{Contrast ratio (CR)} = \frac{\text{Brightness on the "White" state}}{\text{Brightness on the "Black" state}}$$

Note 5 : Definition of cross talk (CT)

$$CT = | YB - YA | / YA \times 100 (\%)$$

Where

YA = Luminance of measured location without gray level 0 pattern (cd/m²)

YB = Luminance of measured location with gray level 0 pattern (cd/m²)

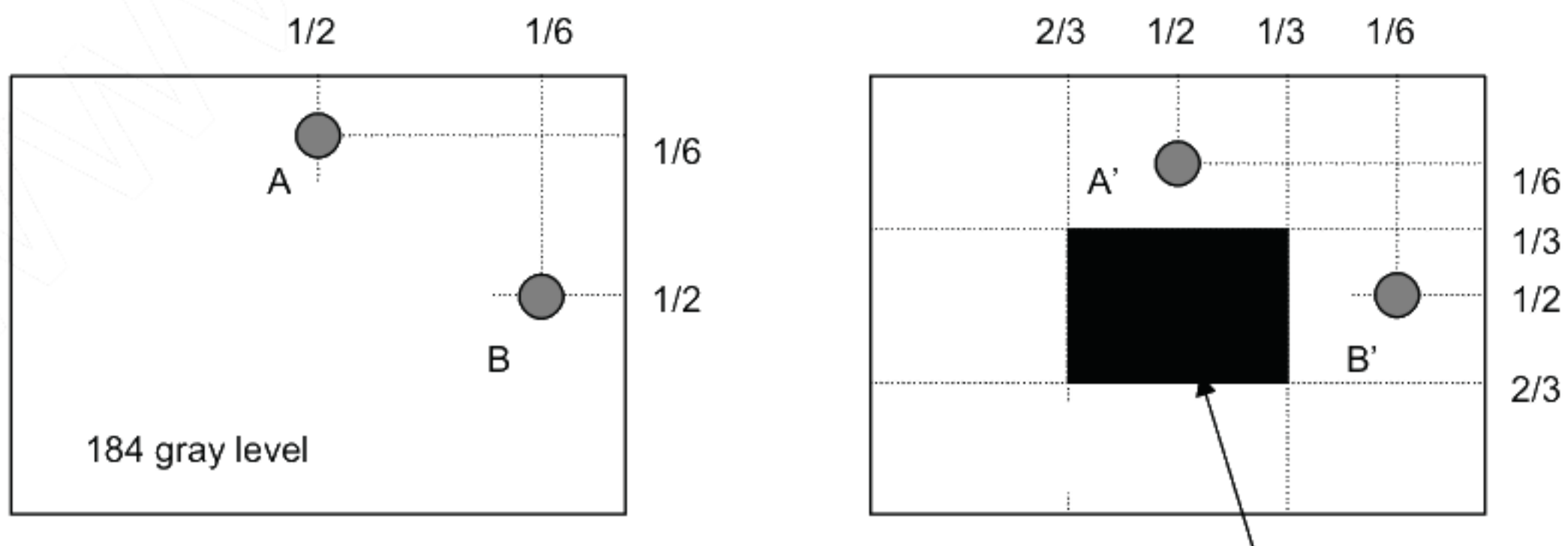

Note 6: Definition of response time:

The output signals of photo detector are measured when the input signals are changed from "White" to "Black" (falling time) and from "Black" to "White" (rising time), respectively. The response time interval is between 10% and 90% of amplitudes. Please refer to the figure as below.

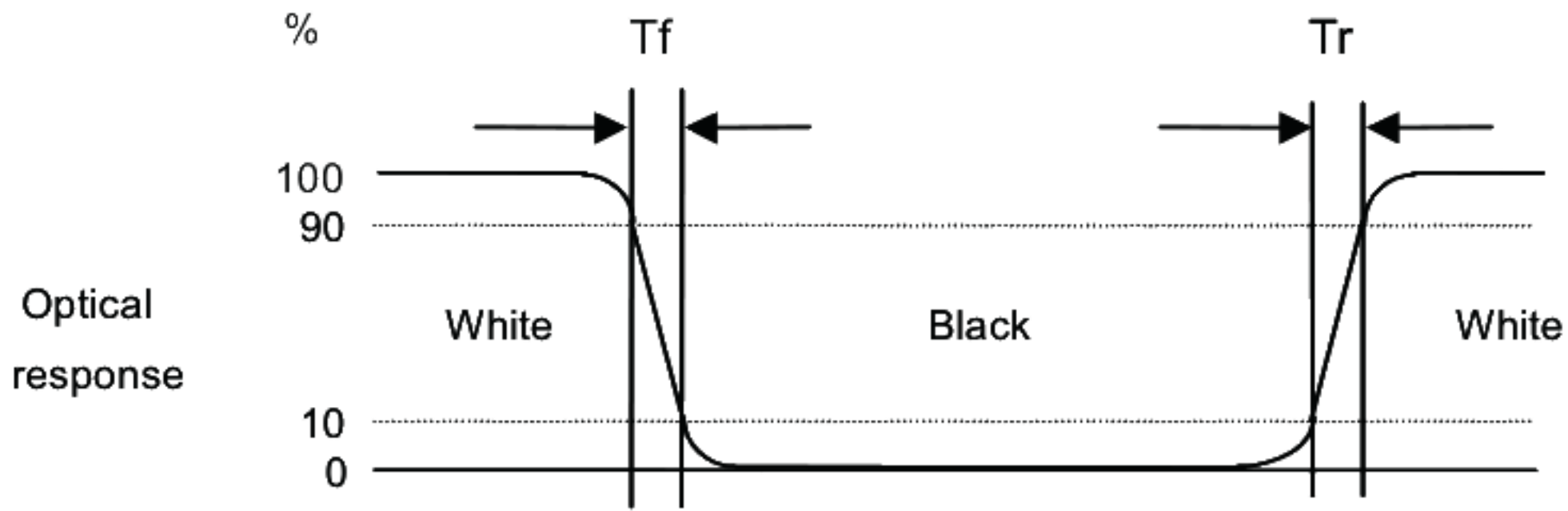

Note 7: Definition of viewing angle

Viewing angle is the measurement of contrast ratio ≥ 10 , at the screen center, over a 180° horizontal and 180° vertical range (off-normal viewing angles). The 180° viewing angle range is broken down as below: 90° (θ) horizontal left and right, and 90° (ϕ) vertical high (up) and low (down). The measurement direction is typically perpendicular to the display surface with the screen rotated to its center to develop the desired measurement viewing angle.

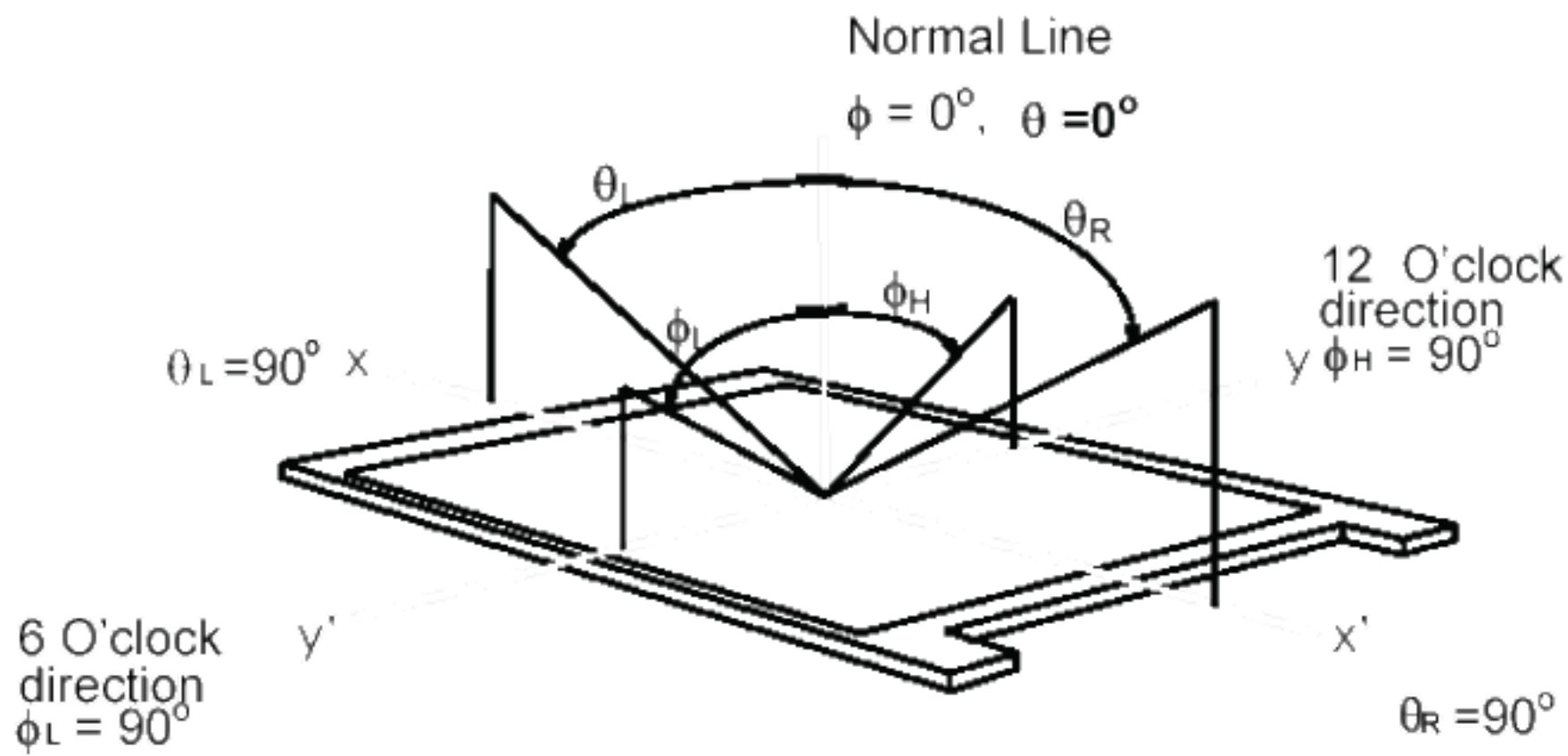

3. Functional Block Diagram

The following diagram shows the functional block of the 15 inch color TFT/LCD module:

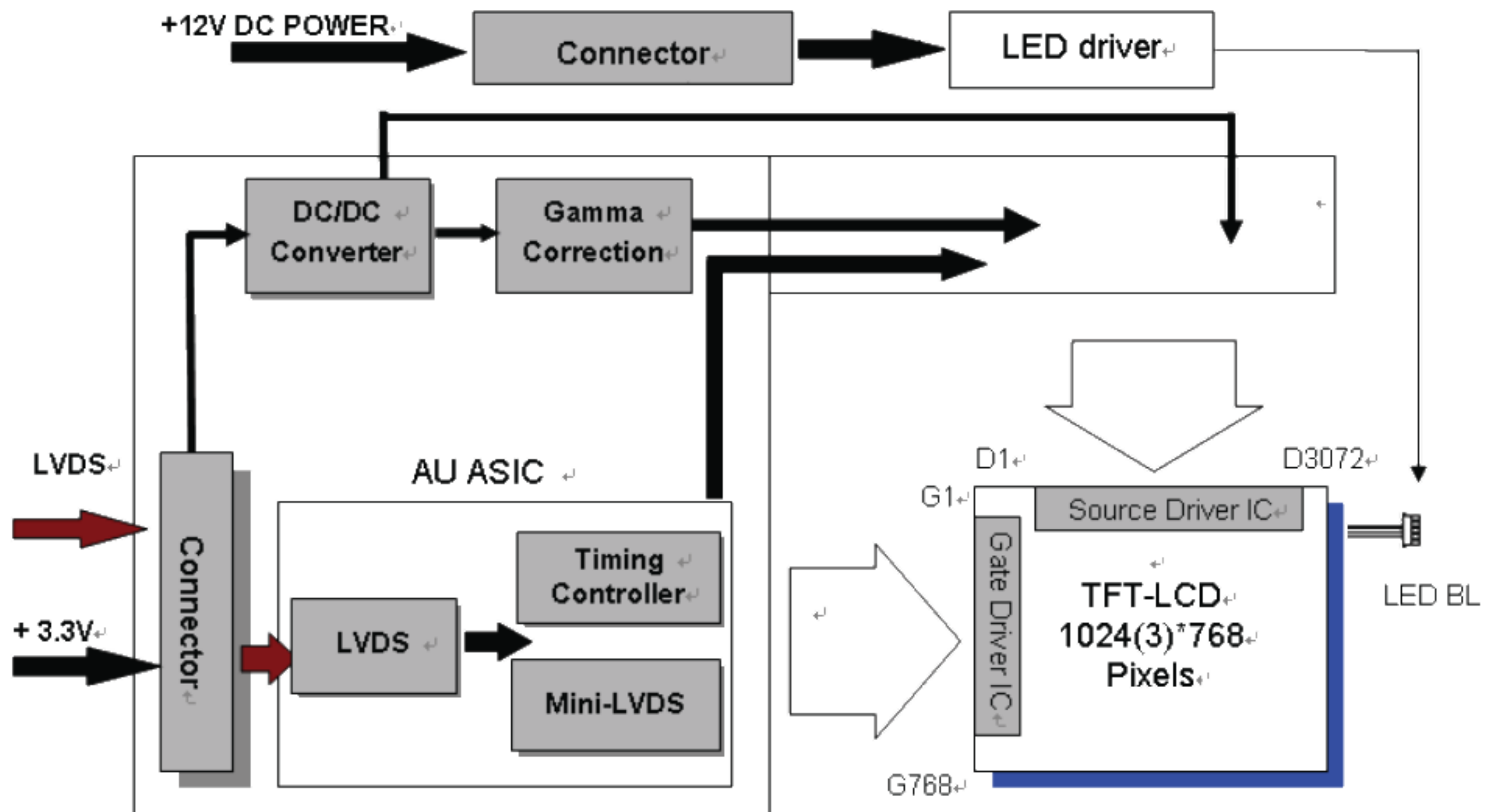

www.panenge.com

4. Absolute Maximum Ratings

4.1 Absolute Ratings of TFT LCD Module

Item	Symbol	Min	Max	Unit
Logic/LCD Drive Voltage	Vin	-0.3	+3.6	[Volt]

4.2 Absolute Ratings of Environment

Item	Symbol	Min	Max	Unit
Operating Temperature	TOP	-30	+85	[°C]
Operation Humidity	HOP	8	90	[%RH]
Storage Temperature	TST	-30	+85	[°C]
Storage Humidity	HST	8	90	[%RH]

Note: Maximum Wet-Bulb should be 39°C and no condensation.

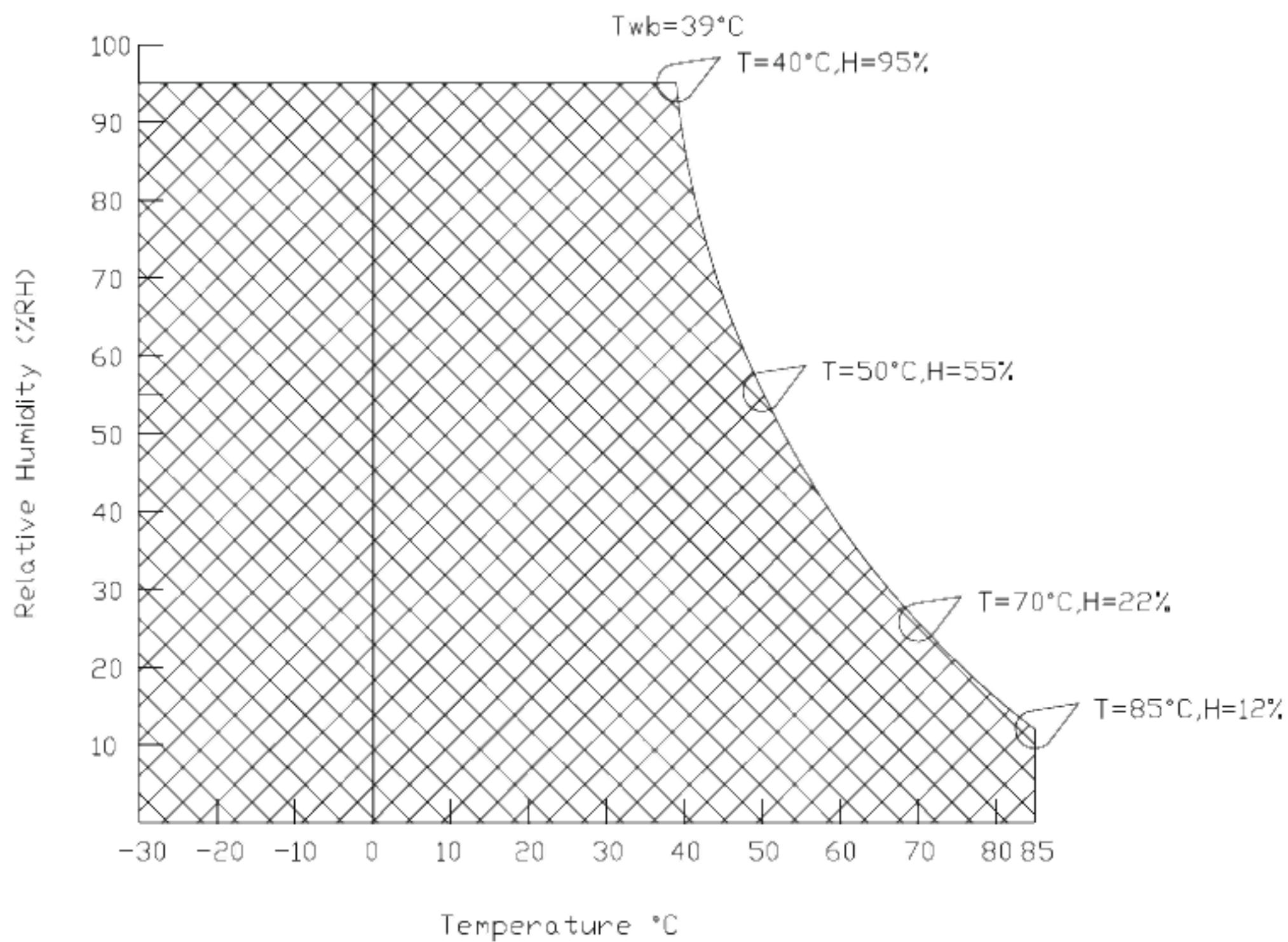

5. Electrical Characteristics

5.1 TFT LCD Module

5.1.1 Power Specification

Symbol	Parameter	Min	Typ	Max	Units	Remark
VDD	Logic/LCD Drive Voltage	3.0	3.3	3.6	[Volt]	± 10%
IDD	VDD Current	-	450	750	[mA]	64 Gray Bar Pattern (VDD=3.3V, at 60Hz)
Irush	LCD Inrush Current	-	-	2	[A]	Note 1
PDD	VDD Power	-	1.49	2.48	[Watt]	64 Gray Bar Pattern (VDD=3.3V, at 60Hz)

Note 1: Measurement condition:

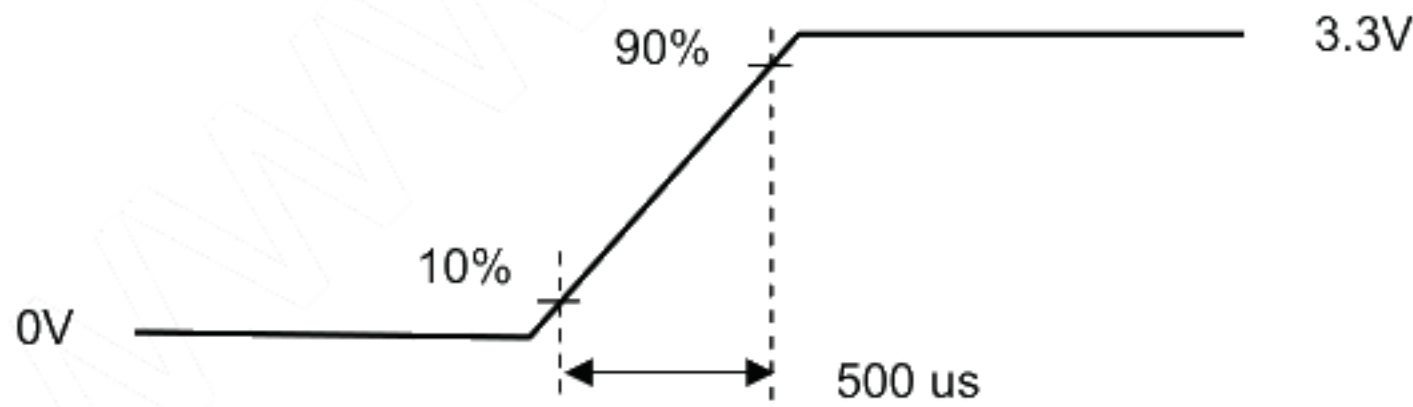
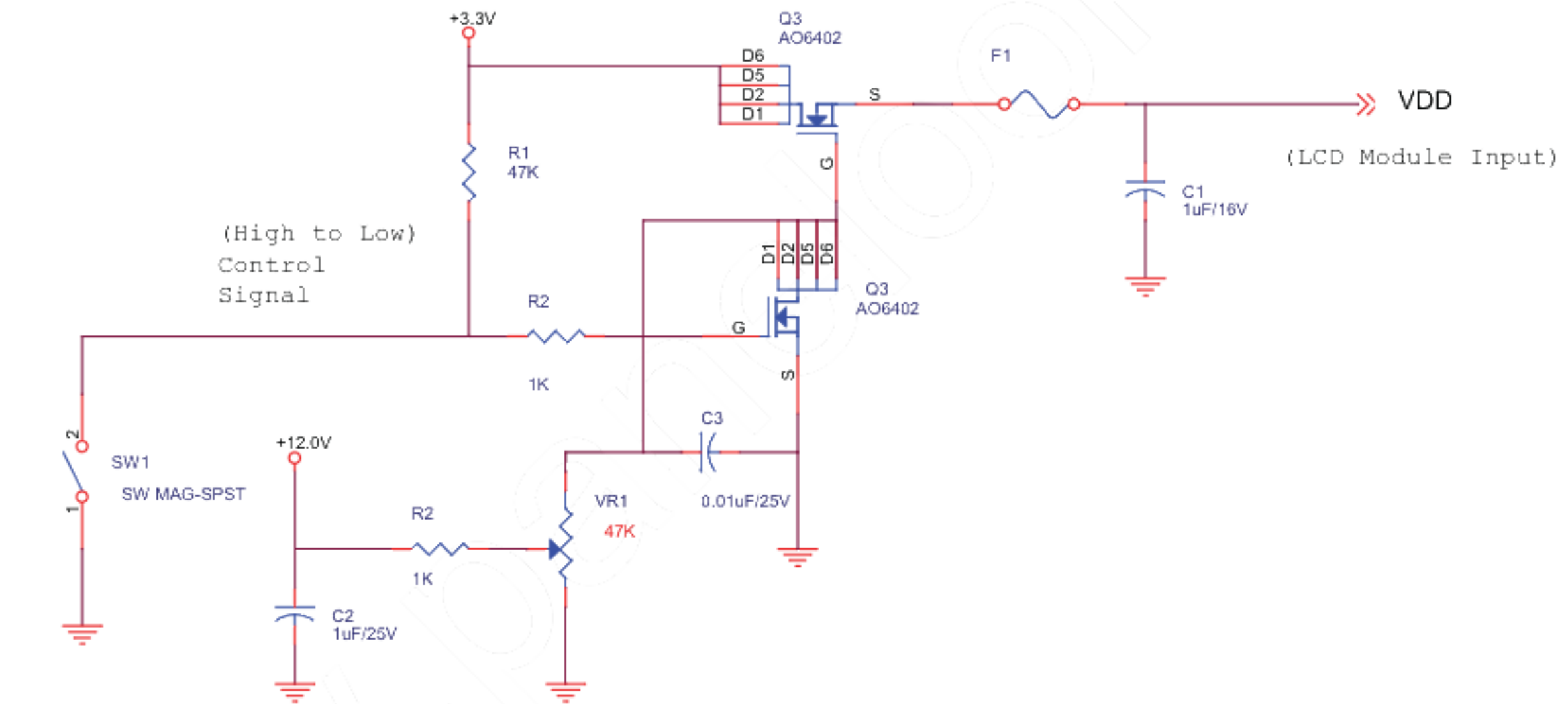

VDD rising time

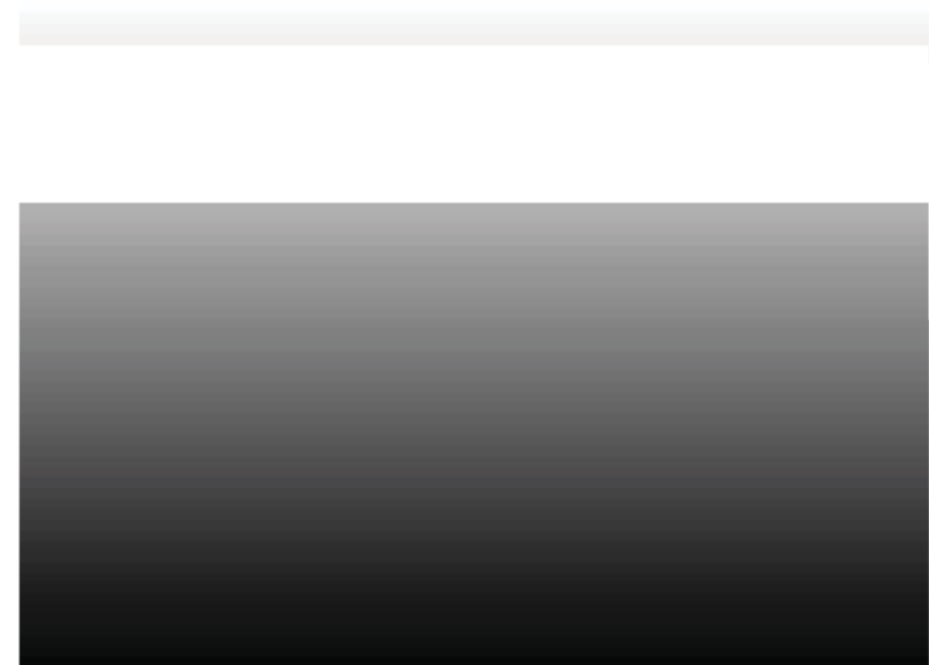

64 Gray pattern

5.1.2 Signal Electrical Characteristics

Input signals shall be low or Hi-Z state when VDD is off.

Symbol	Item	Min.	Typ.	Max.	Unit	Remark
VTH	Differential Input High Threshold	-	-	100	[mV]	VCM=1.2V
VTL	Differential Input Low Threshold	-100	-	-	[mV]	VCM=1.2V
VID	Input Differential Voltage	100	400	600	[mV]	
VICM	Differential Input Common Mode Voltage	1.15	1.2	1.45	[V]	VTH/VTL=±100mV

Note: LVDS Signal Waveform.

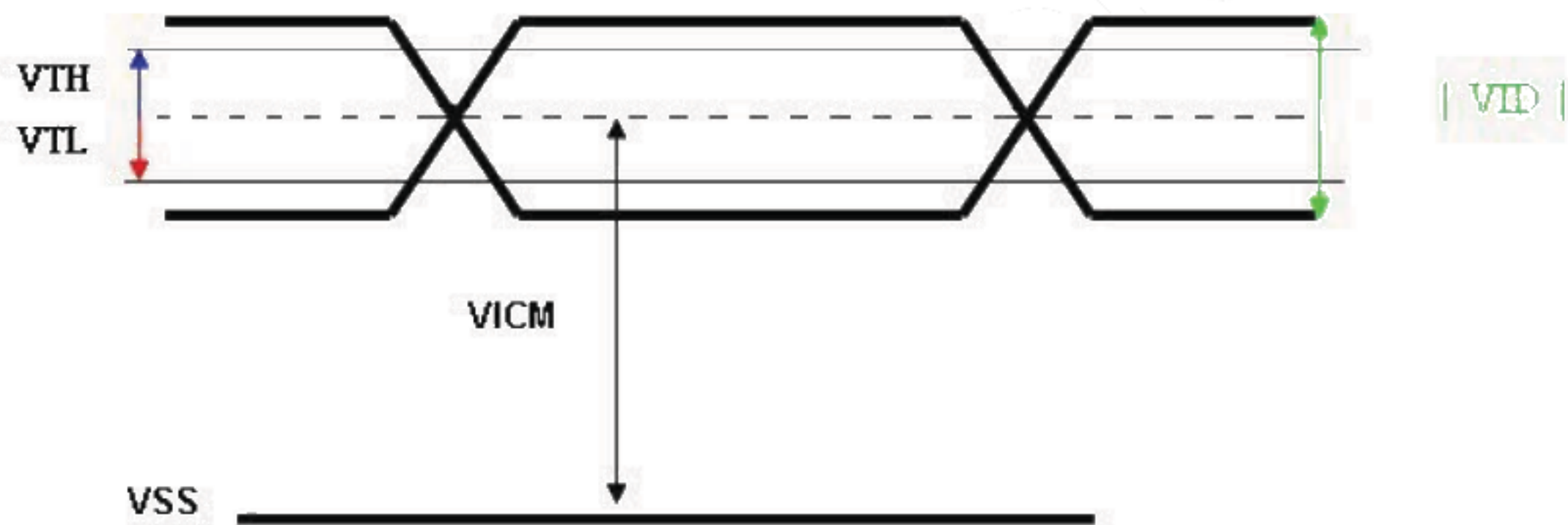

5.2 Backlight Unit

5.2.1 Parameter guideline for LED

Following characteristics are measured under stable condition using a LED driving board at 25°C (Room Temperature).

Symbol	Parameter	Min	Typ	Max	Unit	Remark
Vcc	Input Voltage	10.8	12	13.2	Volt	
Ivcc	Input Current	-	0.62	0.84	A	100% Dimming
PLED	Power Consumption	-	7.43	10.13	Watt	100% Dimming
Irush	Inrush Current	-		2	A	
VLED on/off	On Control Voltage	3.0		5.5	Volt	
	Off Control Voltage	-		0.8	Volt	
FPWM	PWM Dimming Frequency	200	-	20k	Hz	
	High Voltage	3.0		5.5	Volt	
	Low Voltage	-		0.8	Volt	
	Dimming Duty Cycle	5	-	100	%	
I _F	LED Forward Current	-	50		mA	Ta = 25°C
LED Life		50,000	70,000	-	Hrs	Ta = 25°C

Note 1: Ta means ambient temperature of TFT-LCD module.

Note 2: If G150XTN06.0 module is driven at high ambient temperature & humidity condition. The operating life will be reduced.

Note 3: LED life means brightness goes down to 50% initial brightness. Min. operating life time is estimated data.

6. Signal Characteristic

6.1 Pixel Format Image

Following figure shows the relationship between input signal and LCD pixel format.

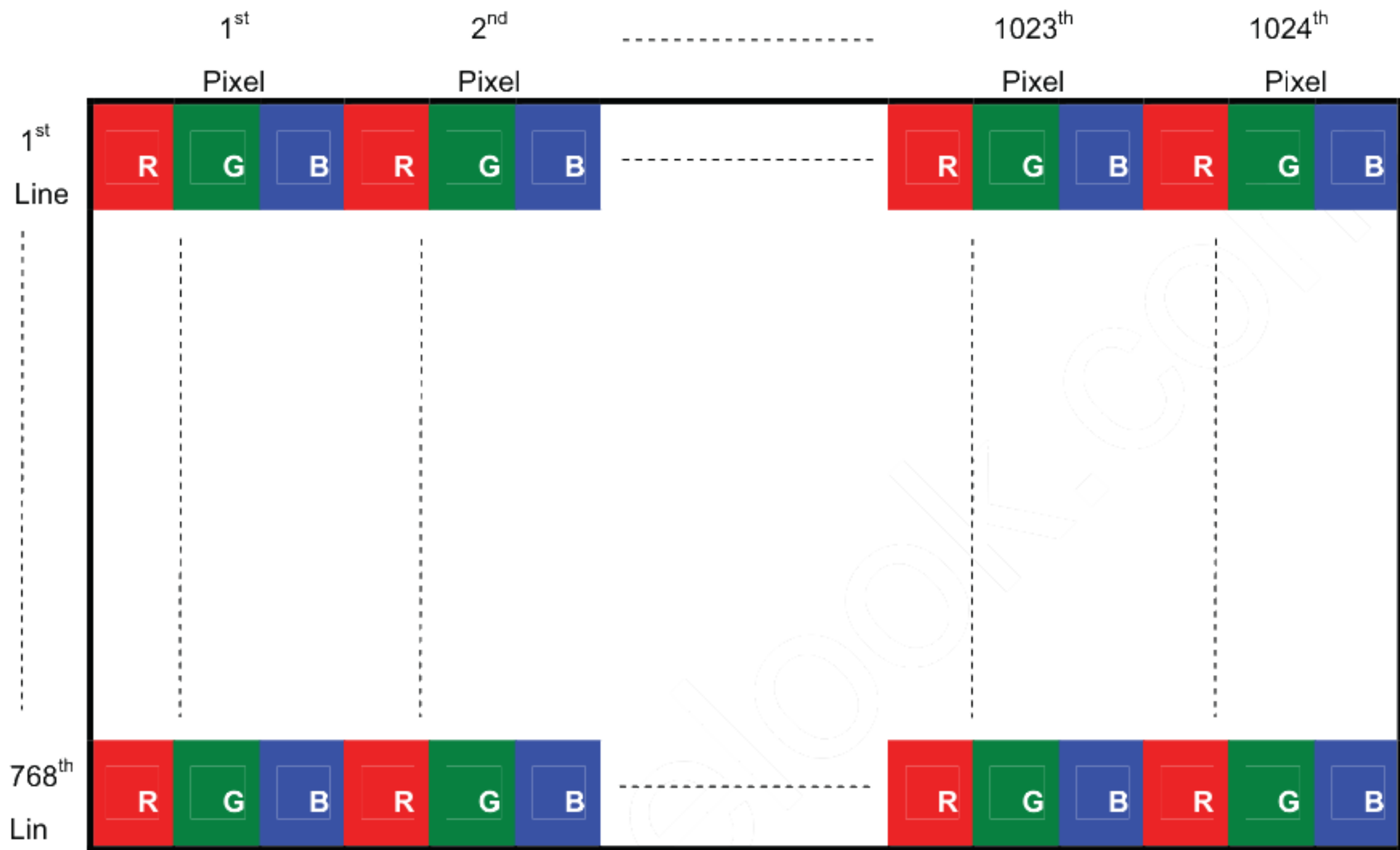

6.2 Scanning Direction

The following figures show the image seen from the front view. The arrow indicates the direction of scan.



6.3 Signal Description

LVDS is a differential signal technology for LCD interface and high speed data transfer device.

Pin No.	Symbol	Description
1	VDD	Power Supply, 3.3V (typical)
2	VDD	Power Supply, 3.3V (typical)
3	NC	No Connect
4	Reverse	Reverse
5	Rin1-	- LVDS differential data input
6	Rin1+	+ LVDS differential data input
7	VSS	Ground
8	Rin2-	- LVDS differential data input
9	Rin2+	+ LVDS differential data input
10	VSS	Ground
11	Rin3-	- LVDS differential data input
12	Rin3+	+ LVDS differential data input
13	VSS	Ground
14	CIKIN-	- LVDS differential clock input
15	CIKIN+	+ LVDS differential clock input
16	VSS	Ground
17	Rin4-	- LVDS differential data input
18	Rin4+	- LVDS differential data input
19	VSS	Ground
20	SEL LVDS	H or NC: 6bit/L: 8bit

6.4 The Input Data Format

SEL LVDS = "H" or NC for 6 bits LVDS Input

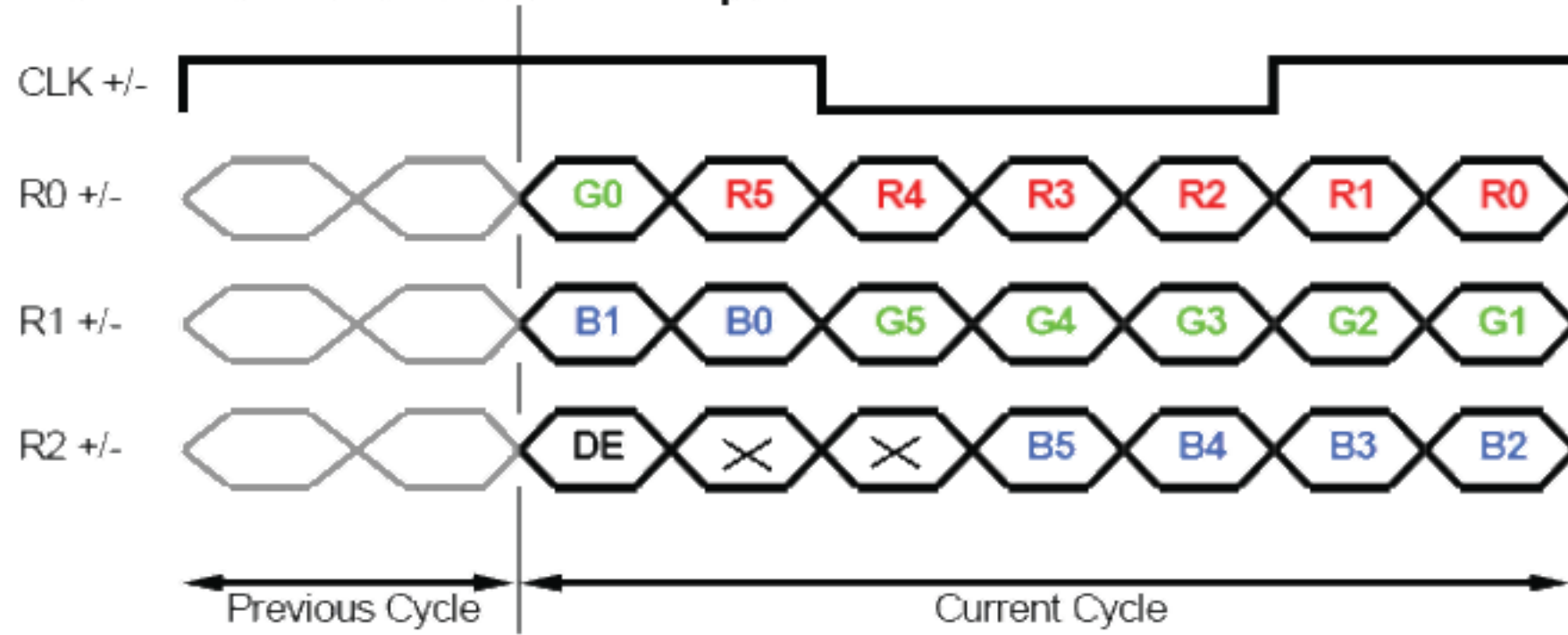

SEL LVDS ="L" for 8 bits LVDS Input

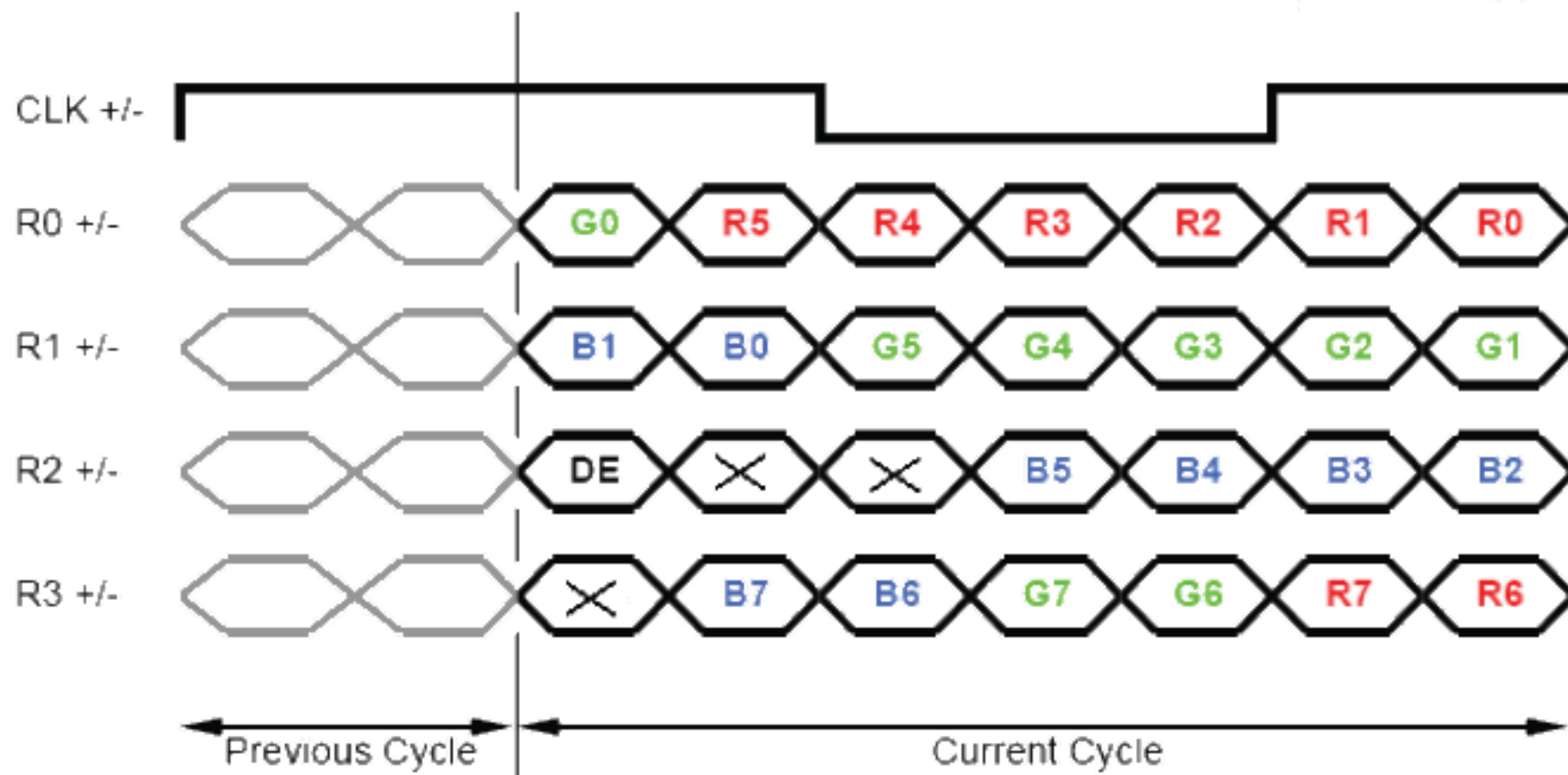

Note1: Please follow PSWG.

Note2: R/G/B data 7:MSB, R/G/B data 0:LSB

6.5 Interface Timing

6.5.1 Timing Characteristics

Signal	Parameter	Symbol	Min.	Typ.	Max.	Unit	
Clock Timing	Clock frequency	$1/T_{\text{Clock}}$	50	65	80	MHz	
Vsync Timing	Vertical Section	Period	T_V	776	806	990	Vsync Timing
		Active	T_{VD}	-	768	-	
		Blanking	T_{VB}	8	38	222	
Hsync Timing	Horizontal Section	Period	T_H	1094	1344	1720	Hsync Timing
		Active	T_{HD}	-	1024	-	
		Blanking	T_{HB}	70	320	696	
Frame Rate		F	50	60	75	Hz	

Note: DE mode only.

Note : Typical value refer to VESA STANDARD

6.5.2 Input Timing Diagram

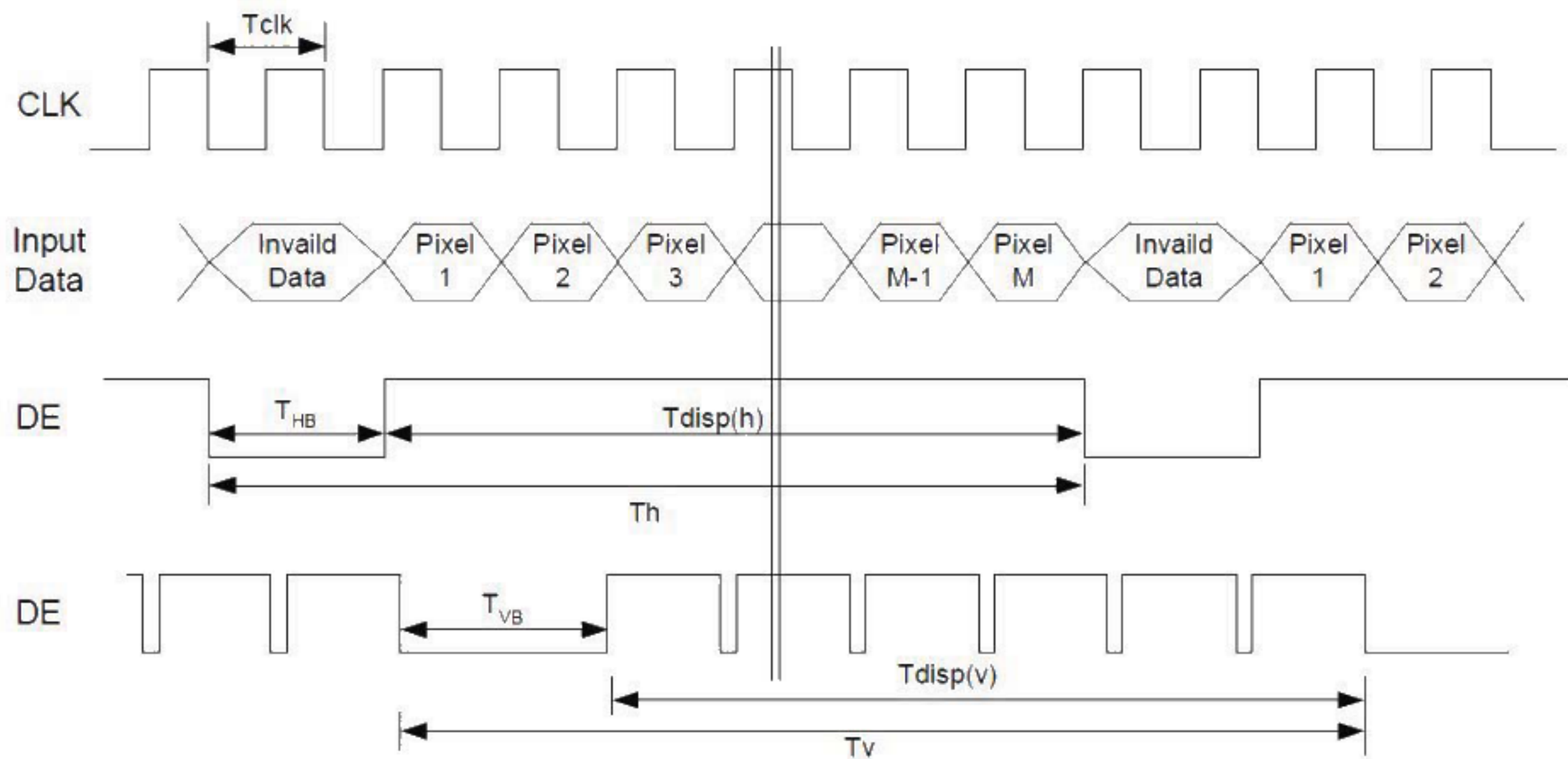

6.6 Power ON/OFF Sequence

VDD power and LED on/off sequence is as below. Interface signals are also shown in the chart. Signals from any system shall be Hi-Z state or low level when VDD is off.

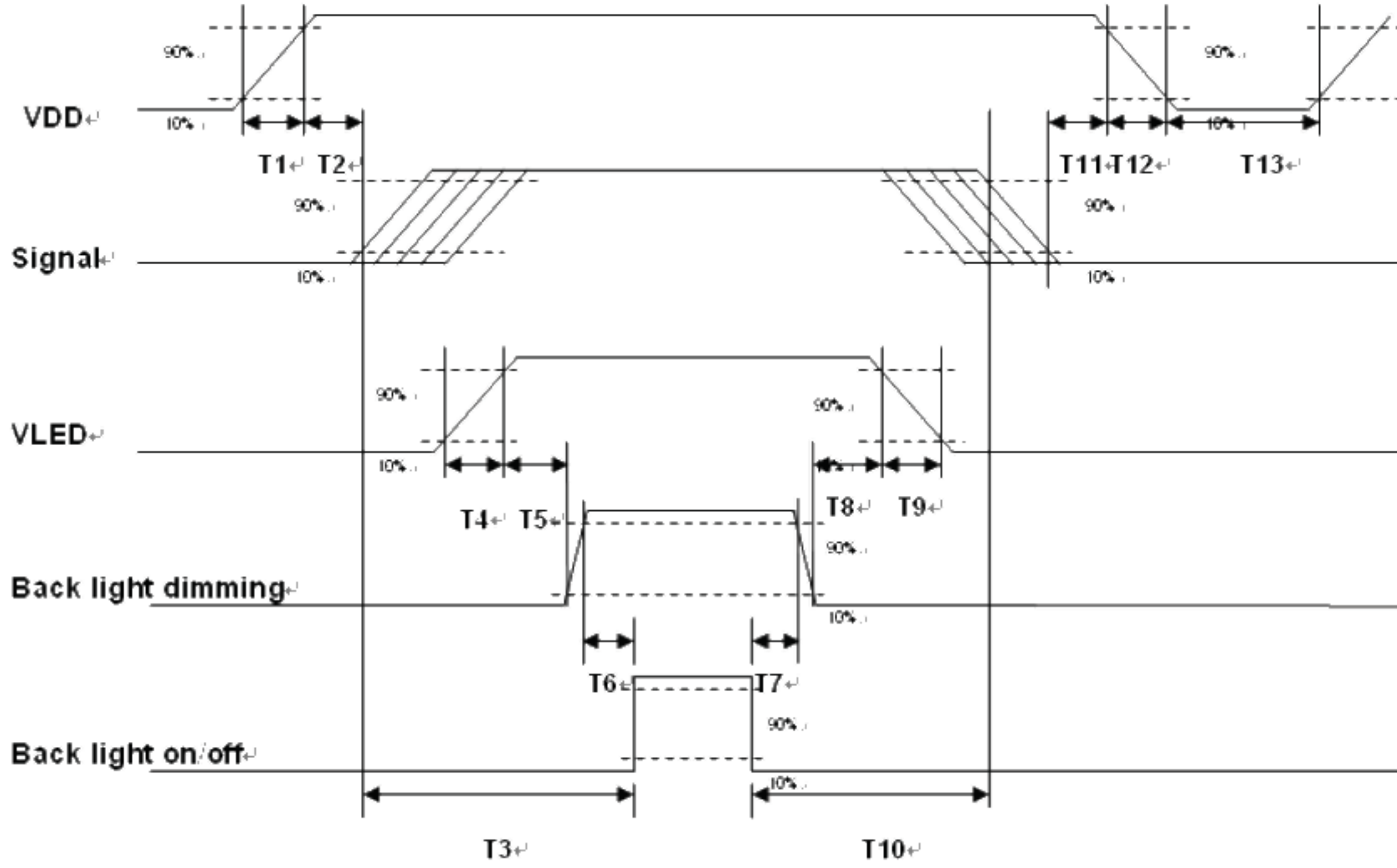

Power ON/OFF sequence timing

Parameter	Value			Units
	Min.	Typ.	Max.	
T1	0.5	-	10	[ms]
T2	30	40	50	[ms]
T3	220	-	-	[ms]
T4	0.5	-	10	[ms]
T5	10	-	-	[ms]
T6	10	-	-	[ms]
T7	0	-	-	[ms]
T8	10	-	-	[ms]
T9	-	-	10	[ms]
T10	110	-	-	[ms]
T11	0	16	50	[ms]
T12	-	-	10	[ms]
T13	1000	-	-	[ms]

The above on/off sequence should be applied to avoid abnormal function in the display. Please make sure to turn off the power when you plug the cable into the input connector or pull the cable out of the connector.

7. Connector & Pin Assignment

Physical interface is described as for the connector on module. These connectors are capable of accommodating the following signals and will be following components.

7.1 TFT LCD Module: LVDS Connector

Connector Name / Designation	Signal Connector
Manufacturer	STM or compatible
Connector Model Number	MSB240420E or compatible
Mating Model Number	P240420 or compatible

Pin#	Signal Name	Pin#	Signal Name
1	VDD	2	VDD
3	NC	4	Reverse
5	Rin1-	6	Rin1+
7	VSS	8	Rin2-
9	Rin2+	10	VSS
11	Rin3-	12	Rin3+
13	VSS	14	ClkIN-
15	ClkIN+	16	VSS
17	Rin4-	18	Rin4+
19	VSS	20	SEL68

7.1.1 Connector Illustration

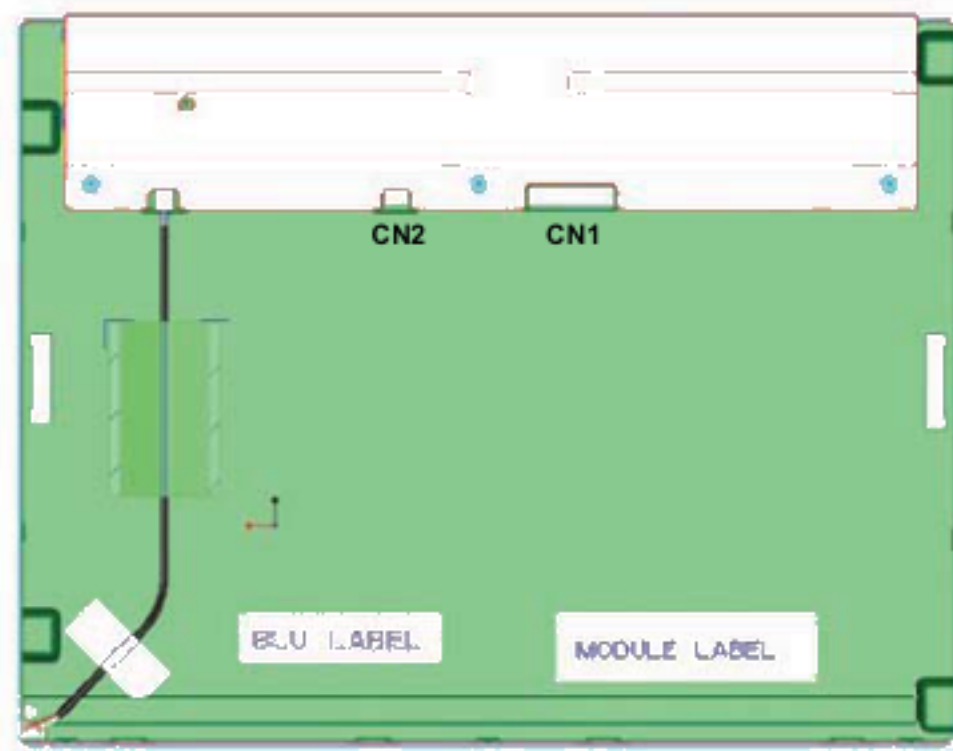

LVDS(CN1):

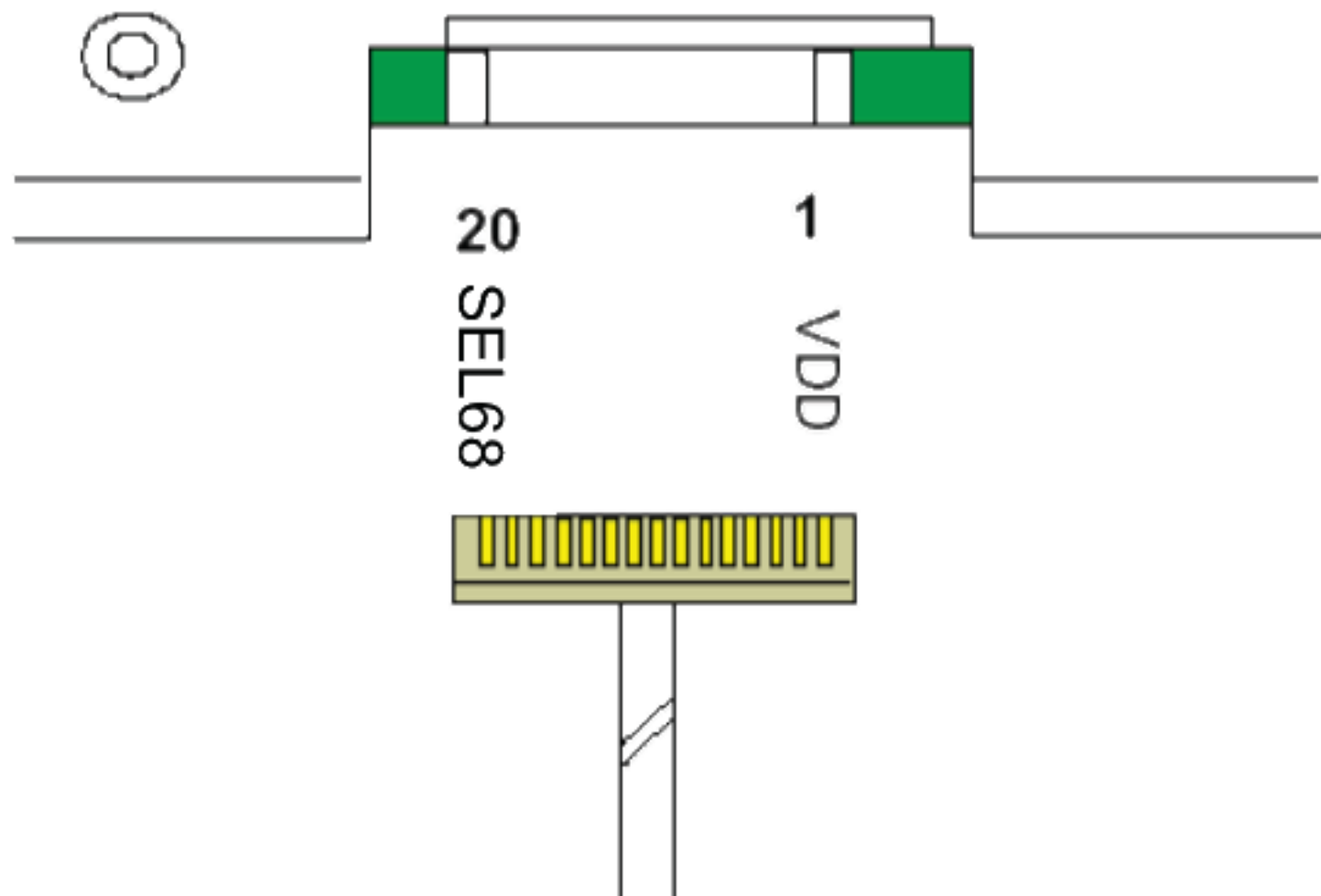

BLU Power in(CN2):

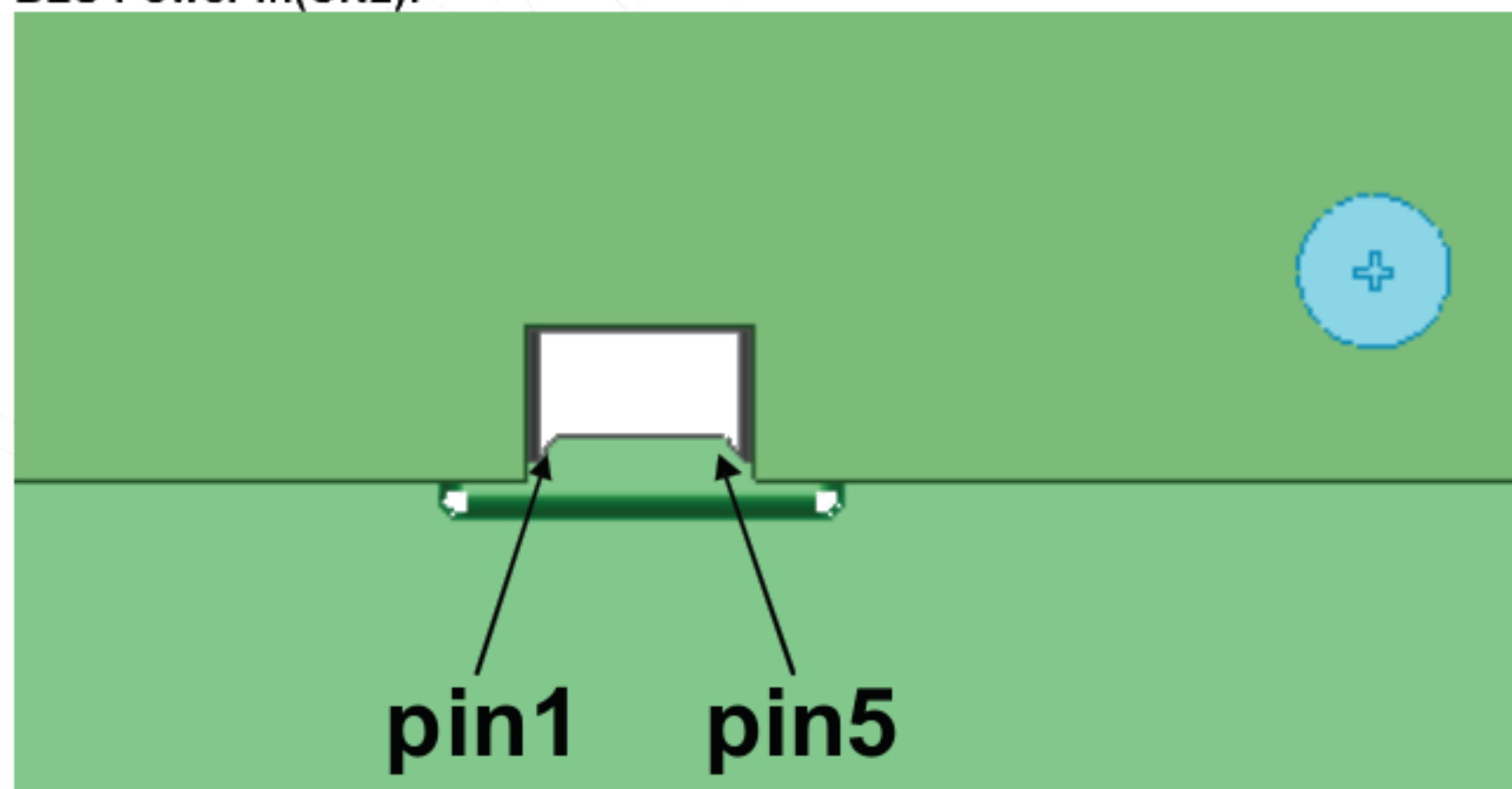

7.2 Backlight Unit: LED Driver Connector

Connector Name / Designation	LED Driver Connector
Manufacturer	ENTERY or compatible
Connector Model Number	3808K-F05N-12R or compatible
Mating Model Number	H208K-P05N-02B or compatible

7.3 LED Connector Pin Assignment

Pin#	Symbol	Signal Name
1	Vcc	12V
2	GND	GND
3	Enable	VLED On/Off
4	Dimming	PWM Dimming
5	NC	NC

8. Reliability Test Criteria

Items	Required Condition	Note
Temperature Humidity Bias	50°C/80%,300 hours	
High Temperature Operation	85°C ,300 hours	
Low Temperature Operation	-30°C ,300 hours	
Hot Storage	85°C ,300 hours	
Cold Storage	-30°C ,300 hours	
Thermal Shock Test	-20°C/30 min ,60°C/30 min ,100cycles	
Shock Test (Non-Operating)	50G,20ms,Half-sine wave,(±X, ±Y, ±Z)	
Vibration Test (Non-Operating)	1.5G, (10~200Hz, P-P) 30 mins/axis (X, Y, Z)	
On/off test	On/10 sec, Off/10 sec, 30,000 cycles	
ESD	Contact Discharge: ± 8KV, 150pF(330Ω) 1sec, 8 points, 25 times/ point Air Discharge: ± 15KV, 150pF(330Ω) 1sec, 8 points, 25 times/ point	Note 1

Note1: According to EN61000-4-2, ESD class B: Some performance degradation allowed. No data lost
 . Self-recoverable. No hardware failures.

Note 2:

- Water condensation is not allowed for each test items.
- Each test is done by new TFT-LCD module. Don't use the same TFT-LCD module repeatedly for reliability test.
- The reliability test is performed only to examine the TFT-LCD module capability.
- To inspect TFT-LCD module after reliability test, please store it at room temperature and room humidity for 24 hours at least in advance.
- No function failure occurs. Mura shall be ignored after high temperature reliability test

9. Mechanical Characteristics

9.1 LCM Outline Dimension (Front View and back view)

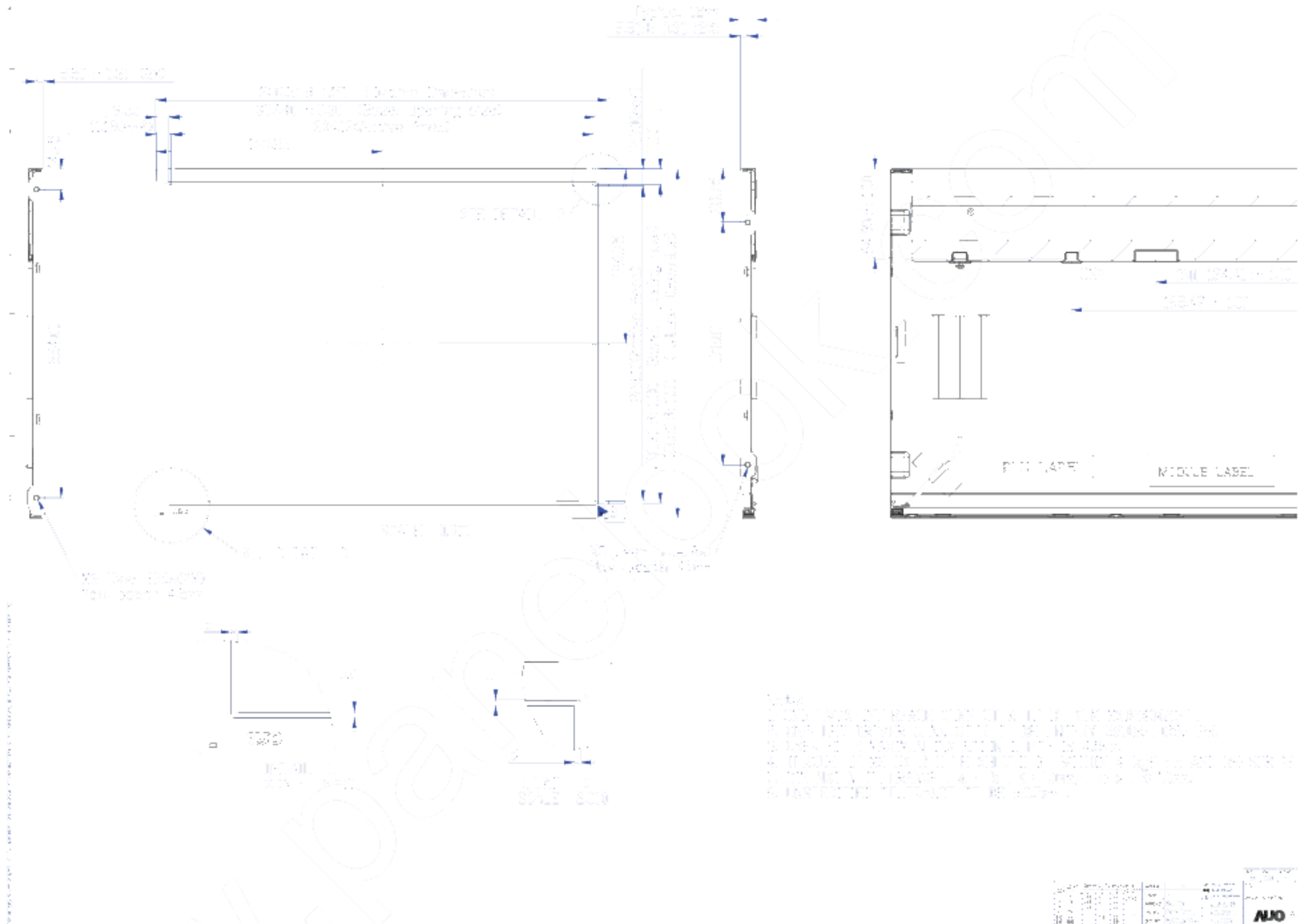

10. Label and Packaging

10.1 Shipping Label (on the rear side of TFT-LCD display)

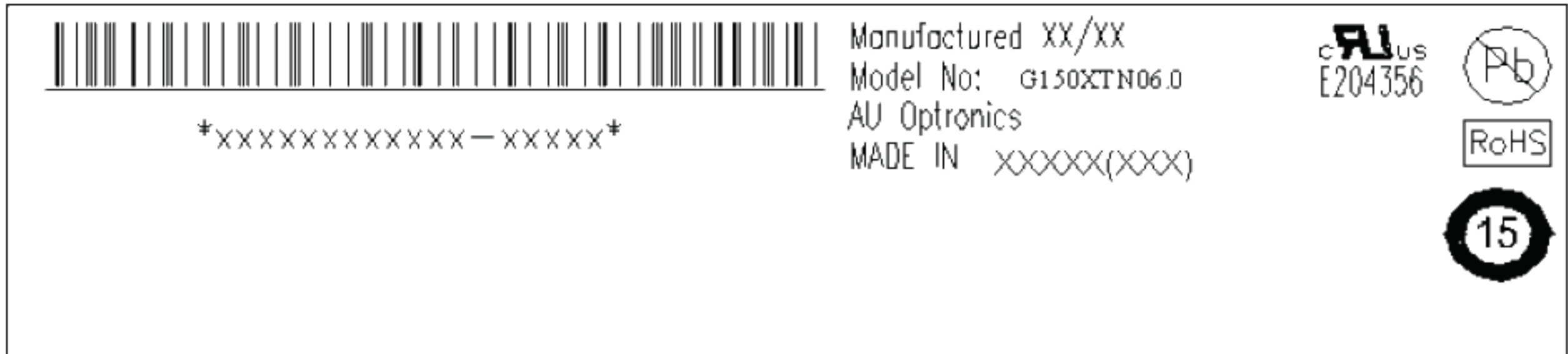

10.2 Carton Package

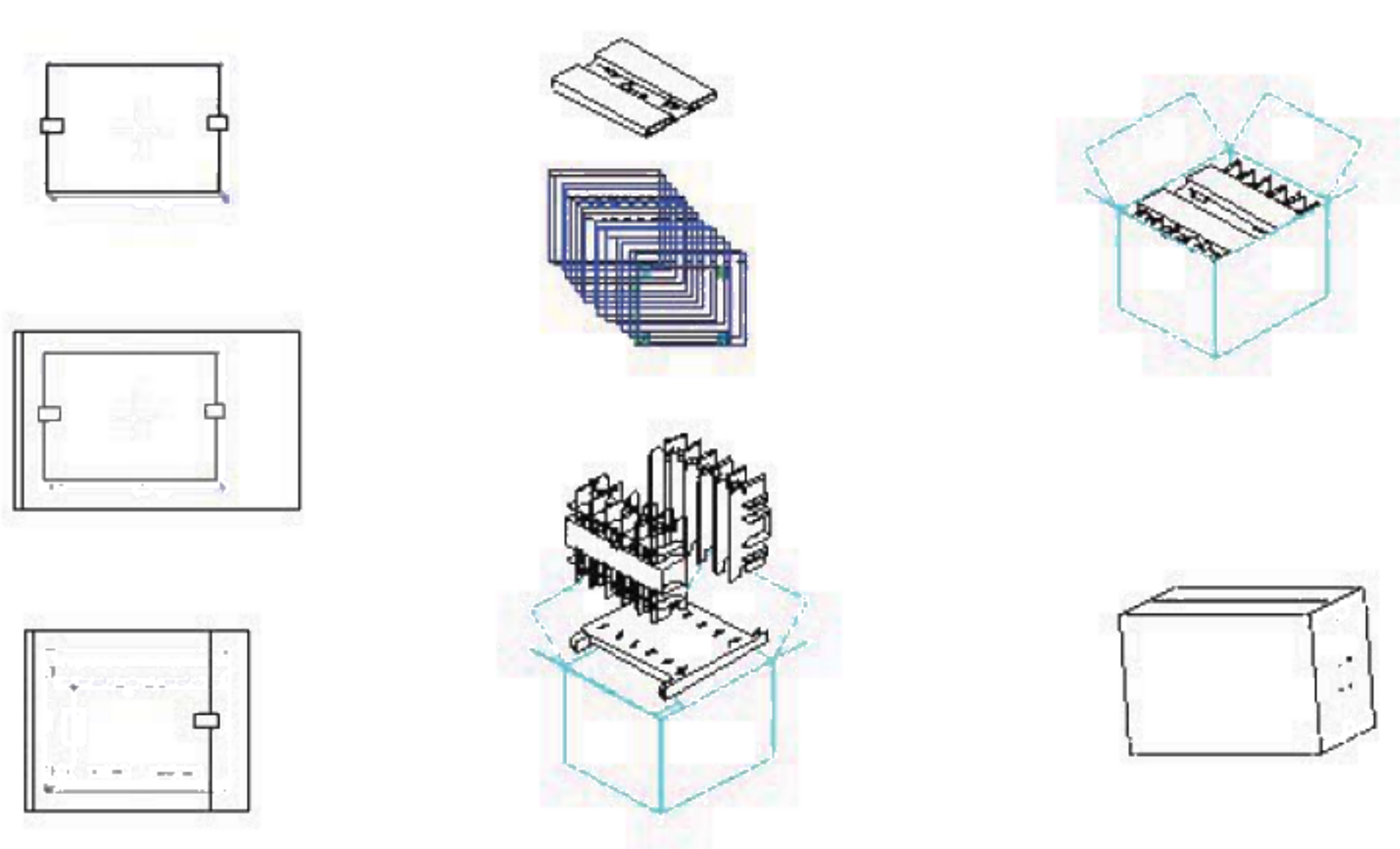

Max capacity : 15pcs TFT-LCD module per carton
 Max weight: 18.5 kg per carton
 Outside dimension of carton: 434(L) mm x 380(W) mm x 353(H) mm
 Pallet size : 1140 mm * 890 mm * 135 mm

* Palletizing

Module by air : (2 *3) *4 layers , one pallet put 24 boxes , total 360pcs module
 Module by sea : (2 *3) *4 layers+ (2 *3) *1 layers , two pallet put 30 boxes , total 450pcs module
 Module by sea_HQ : (2 *3) *4 layers+ (2 *3) *2 layers , two pallet put 36 boxes , total 540pcs module

11 Safety

11.1 Sharp Edge Requirements

There will be no sharp edges or comers on the display assembly that could cause injury.

11.2 Materials

11.2.1 Toxicity

There will be no carcinogenic materials used anywhere in the display module. If toxic materials are used, they will be reviewed and approved by the responsible AUO toxicologist.

11.2.2 Flammability

All components including electrical components that do not meet the flammability grade UL94-V1 in the module will complete the flammability rating exception approval process.

The printed circuit board will be made from material rated 94-V1 or better. The actual UL flammability rating will be printed on the printed circuit board.

11.3 Capacitors

If any polarized capacitors are used in the display assembly, provisions will be made to keep them from being inserted backwards.

11.4 National Test Lab Requirement

The display module will satisfy all requirements for compliance to:

UL 60950-1, Second Edition

U.S.A. Information Technology Equipment