



Product Specification

AU OPTRONICS CORPORATION

Contents

1. Handling Precautions	4
2. General Description	5
2.1 General Specification	5
2.2 Optical Characteristics	6
3. Functional Block Diagram	10
4. Absolute Maximum Ratings	10
4.1 Absolute Ratings of TFT LCD Module	10
4.2 Absolute Ratings of Environment	11
5. Electrical Characteristics	12
5.1 TFT LCD Module	12
5.2 Backlight Unit	14
6. Signal Interface Characteristic	15
6.1 Pixel Format Image	15
6.2 The Input Data Format	16
6.3 Signal Description (CN1)	17
6.4 Interface Timing (LVDS)	18
6.5 Power ON/OFF Sequence	19
7. Connector & Pin Assignment	20
7.1 TFT LCD Module	20
7.2 Backlight Unit	21
8. Panel Reliability Test	23
9. Label and Package	24
9.1 Shipping Label Format	24
9.2 Carton Package	24
10. Mechanical Characteristics	25
10.1 LCM Outline Dimension (Front View)	25
10.2 LCM Outline Dimension (Rear View)	26



Product Specification
AU OPTRONICS CORPORATION

Record of Revision

Version and Date	Page	Old Description	New Description	Remark
0.1 2019/1/11	All	First Final specification		
1.0			Final spec	



Product Specification

AU OPTRONICS CORPORATION

1. Handling Precautions

- 1) Since front polarizer is easily damaged, please be cautious and not to scratch it.
- 2) Be sure to turn off power supply when inserting or disconnecting from input connector.
- 3) Wipe off water drop immediately. Long contact with water may cause discoloration or spots.
- 4) When the panel surface is soiled, wipe it with absorbent cotton or soft cloth.
- 5) Since the panel is made of glass, it may be broken or cracked if dropped or bumped on hard surface.
- 6) To avoid ESD (Electro Static Discharge) damage, be sure to ground yourself before handling TFT-LCD Module.
- 7) Do not open nor modify the module assembly.
- 8) Do not press the reflector sheet at the back of the module to any direction.
- 9) In case if a module has to be put back into the packing container slot after it was taken out from the container, do not press the center of the LED light bar edge. Instead, press at the far ends of the LED light bar edge softly. Otherwise the TFT Module may be damaged.
- 10) At the insertion or removal of the Signal Interface Connector, be sure not to rotate nor tilt the Interface Connector of the TFT Module.
- 11) TFT-LCD Module is not allowed to be twisted & bent even force is added on module in a very short time. Please design your display product well to avoid external force applying to module by end-user directly.
- 12) Small amount of materials without flammability grade are used in the TFT-LCD module. The TFT-LCD module should be supplied by power complied with requirements of Limited Power Source (IEC60950-1 or UL60950-1), or be applied exemption.
- 13) Severe temperature condition may result in different luminance, response time and lamp ignition voltage.
- 14) Continuous operating TFT-LCD display under low temperature environment may accelerate lamp exhaustion and reduce luminance dramatically.
- 15) The data on this specification sheet is applicable when LCD module is placed in landscape position.
- 16) Continuous displaying fixed pattern may induce image sticking. It's recommended to use screen saver or shuffle content periodically if fixed pattern is displayed on the screen.



2. General Description

G133HAN01.1 is a Color Active Matrix Liquid Crystal Display composed of a TFT LCD panel, a driver circuit, and LED backlight system. The screen format is intended to support the 16:9 FHD, 1920(H) x1080(V) screen and 16.7M colors (RGB 8-bits data driver) with LED backlight driving circuit.

G133HAN01.1 is designed for a display unit of industrial machine.

2.1 General Specification

The following items are characteristics summary on the table at 25 °C condition:

Items	Unit	Specifications
Screen Diagonal	[inch]	13.3"
Active Area	[mm]	293.472 (H) x 165.078 (V)
Pixels H x V		1920 x 3(RGB) x 1080
Pixel Pitch	[mm]	0.15285x 0.15285
Pixel Format		R.G.B. Vertical Stripe
Display Mode		AHVA
White Luminance (Center)	[cd/m ²]	400 Typ.
Luminance Uniformity		80% (5 points, Typ.)
Contrast Ratio		800:1 (Typ.)
Response Time	[ms]	25 (Typ.)/ 35 (Max.)
Nominal Input Voltage VDD	[Volt]	+3.3 (Typ.)
LCD Power Consumption	[Watt]	1.2W (Max. White Pattern @ VDD: 3.3V)
LED Power Consumption	[Watt]	15W (Max.@VLED: 12V)
Weight	[Grams]	500 (Max.)
Physical Size	[mm]	309.7 x 184.1 x 9.6 (Typ.)
Electrical Interface		LVDS JEIDA 8bit
Surface Treatment		Anti-glare
Support Color		16.7M Colors (RGB 8-bits)
Temperature Range		
Operating	[°C]	-20 to +70
Storage (Non-Operating)	[°C]	-20 to +70



2.2 Optical Characteristics

The optical characteristics are measured under stable conditions at 25°C (Room Temperature) :

Item	Unit	Conditions	Min.	Typ.	Max.	Note			
Central Luminance	cd/m ²		320	400	---	1, 3, 4			
Viewing Angle	degree	Horizontal (Right)	75	89	---	3, 7			
		Horizontal (Left)	75	89	---				
	Vertical	(Upper)	75	89	---				
		(Lower)	75	89	---				
Luminance Uniformity		5 Points	75	80	---	1, 2, 3			
Contrast Ratio			600	800	-	3, 5			
Response Time	msec	Rising + Falling	---	25	35	3, 6			
Color / Chromaticity Coordinates	Red	Rx	CIE 1931	0.625	0.675	0.725	3		
		Ry		0.266	0.316	0.366			
	Green	Gx		0.235	0.285	0.335			
		Gy		0.605	0.655	0.705			
	Blue	Bx		0.103	0.153	0.203			
		By		0.000	0.036	0.086			
	White	Wx		0.263	0.313	0.363			
		Wy		0.279	0.329	0.379			
	NTSC	%			-	90		-	

Note 1: 5 points position (Ref: Active area)

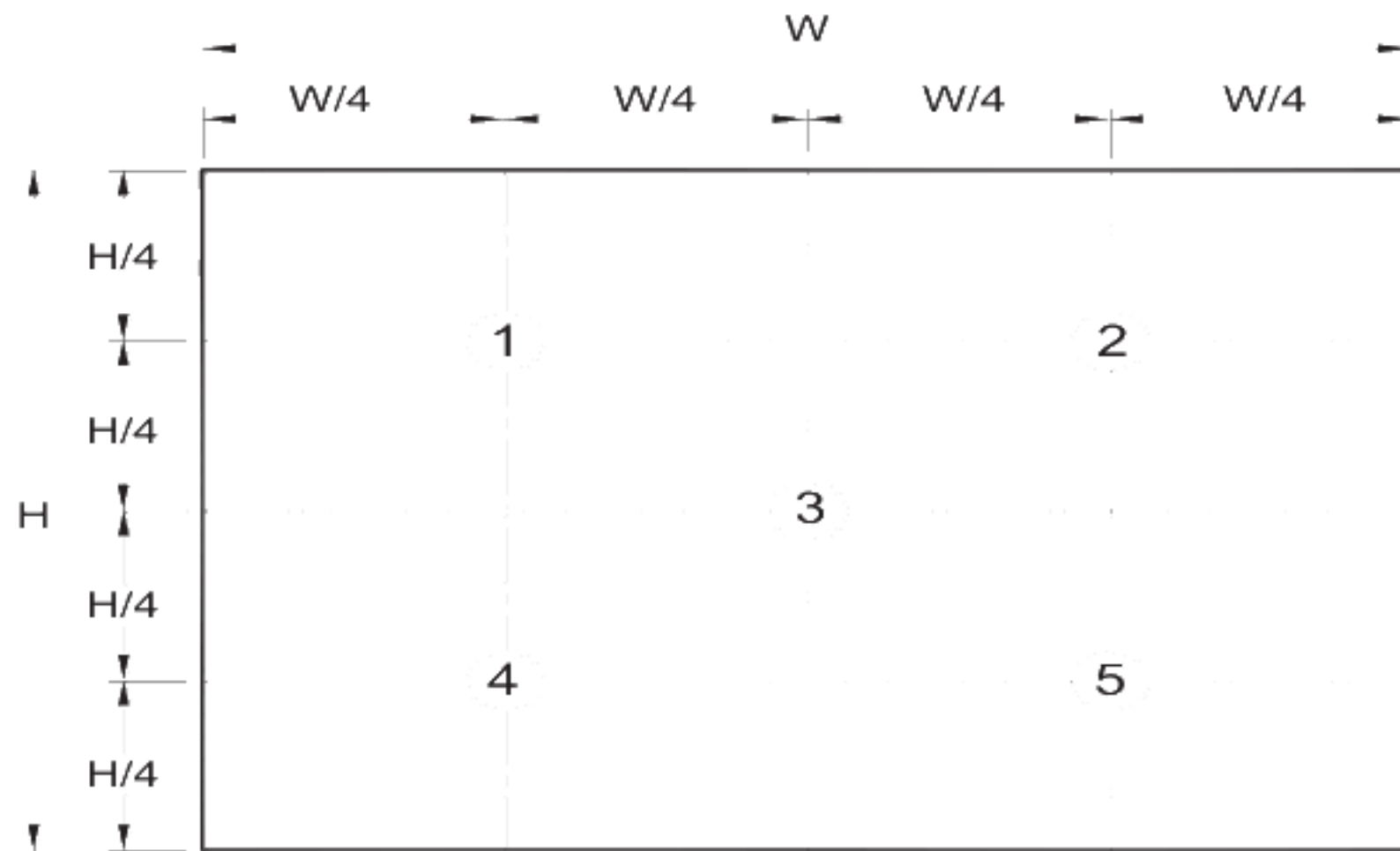

Note 2: The luminance uniformity of 5 points is defined by dividing the maximum luminance values by the minimum test point luminance

$$\delta_{w5} = \frac{\text{Maximum Brightness of five points}}{\text{Minimum Brightness of five points}}$$

Note 3: Measurement method

The LCD module should be stabilized at given temperature for 30 minutes to avoid abrupt temperature change during measuring. In order to stabilize the luminance, the measurement should be executed after lighting Backlight for 30 minutes in a stable, windless and dark room, and it should be measured in the center of screen.

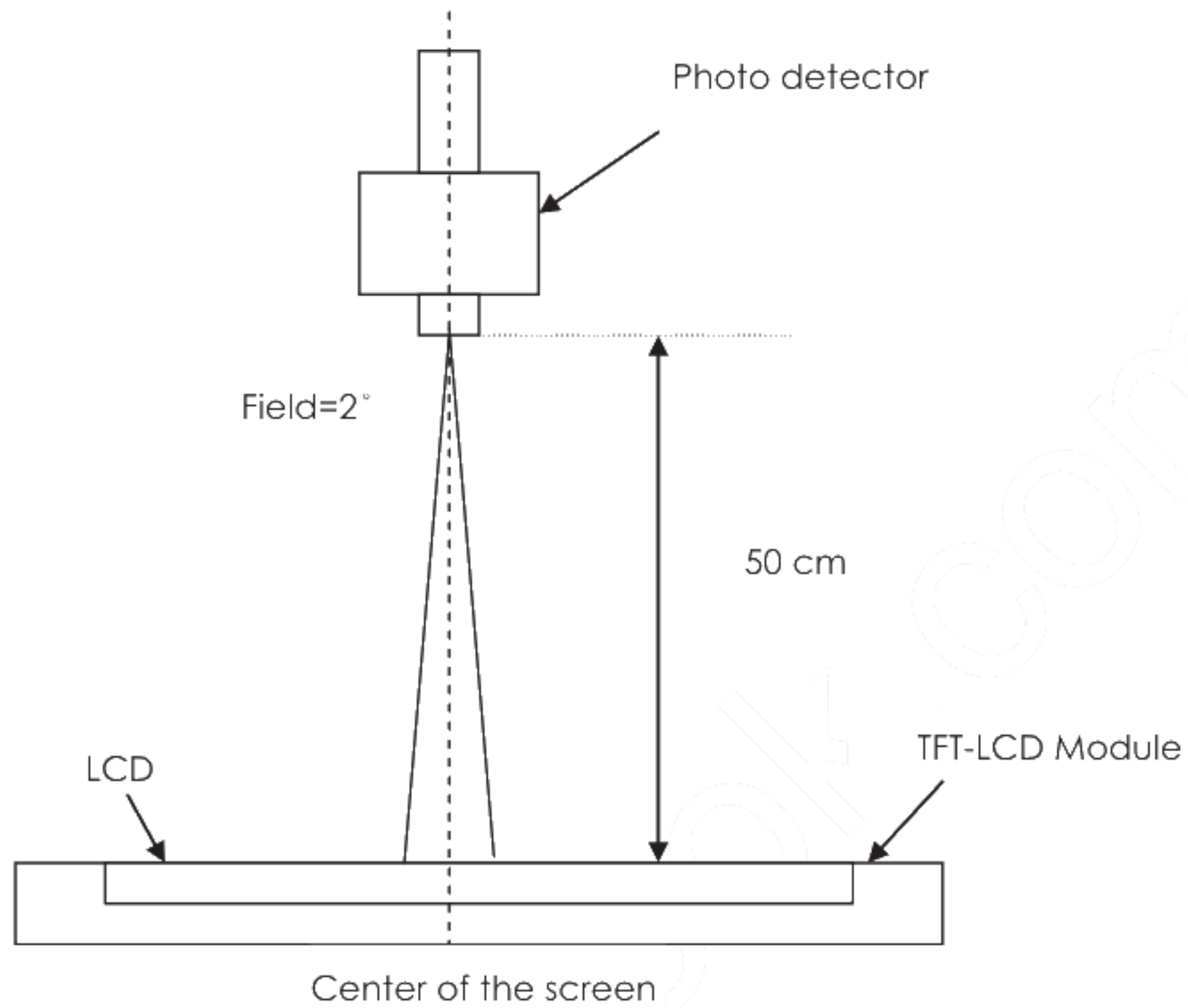

Note 4: Definition of Average Luminance of White (Y_L):

Measure the luminance of gray level 63 at 5 points · $Y_L = [L(1) + L(2) + L(3) + L(4) + L(5)] / 5$

$L(x)$ is corresponding to the luminance of the point X at Figure in Note (1).

Note 5: Definition of contrast ratio:

Contrast ratio is calculated with the following formula.

$$\text{Contrast ratio (CR)} = \frac{\text{Brightness on the "White" state}}{\text{Brightness on the "Black" state}}$$

Note 6: Definition of response time:

The output signals of BM-7 or equivalent are measured when the input signals are changed from "Black" to "White" (falling time) and from "White" to "Black" (rising time), respectively. The response time interval is between the 10% and 90% of amplitudes. Refer to figure as below.

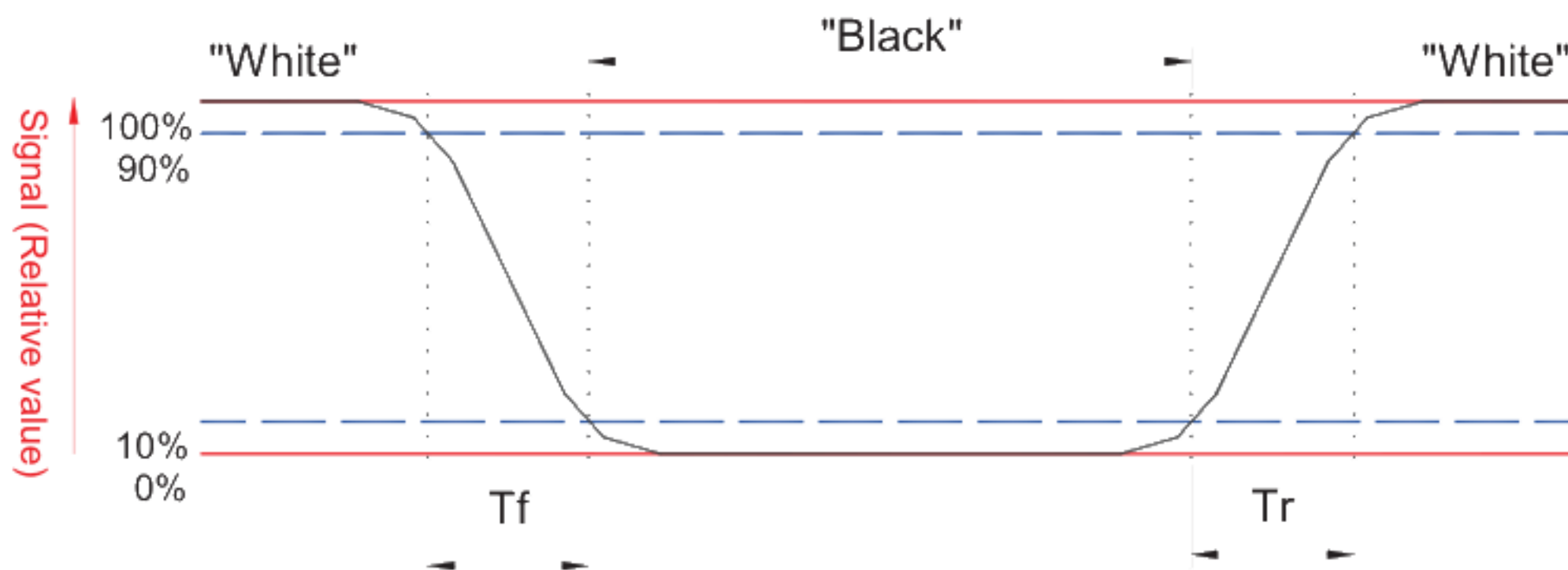

Note 7: Definition of viewing angle

Viewing angle is the measurement of contrast ratio >10, at the screen center, over a 180° horizontal and 180° vertical range (off-normal viewing angles). The 180° viewing angle range is broken down as follows; 90° (θ) horizontal left and right and 90° (ϕ) vertical, high (up) and low (down). The measurement direction is typically perpendicular to the display surface with the screen rotated about its center to develop the desired measurement viewing angle.

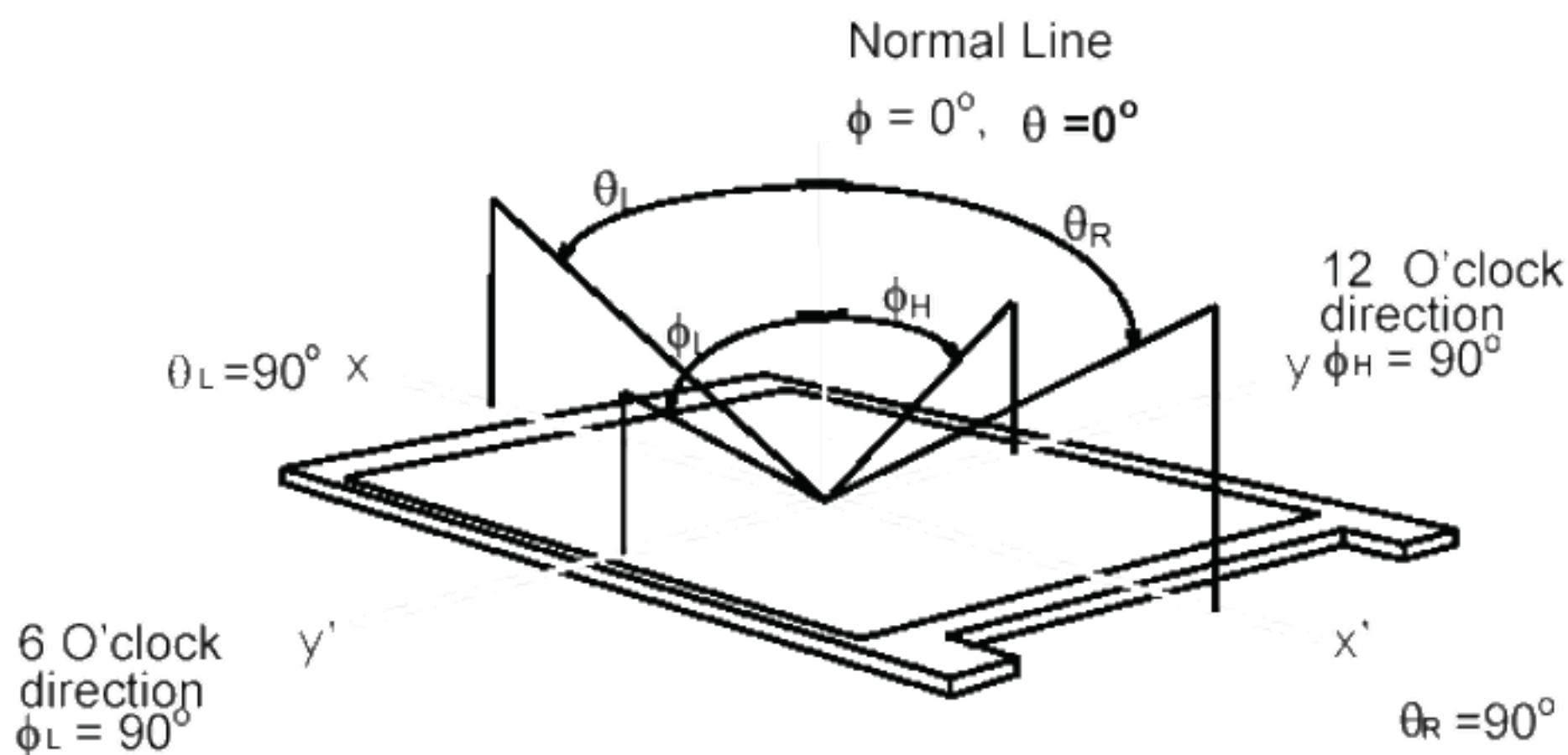

3. Functional Block Diagram

The following diagram shows the functional block of the 13.3 inch Color TFT-LCD Module:

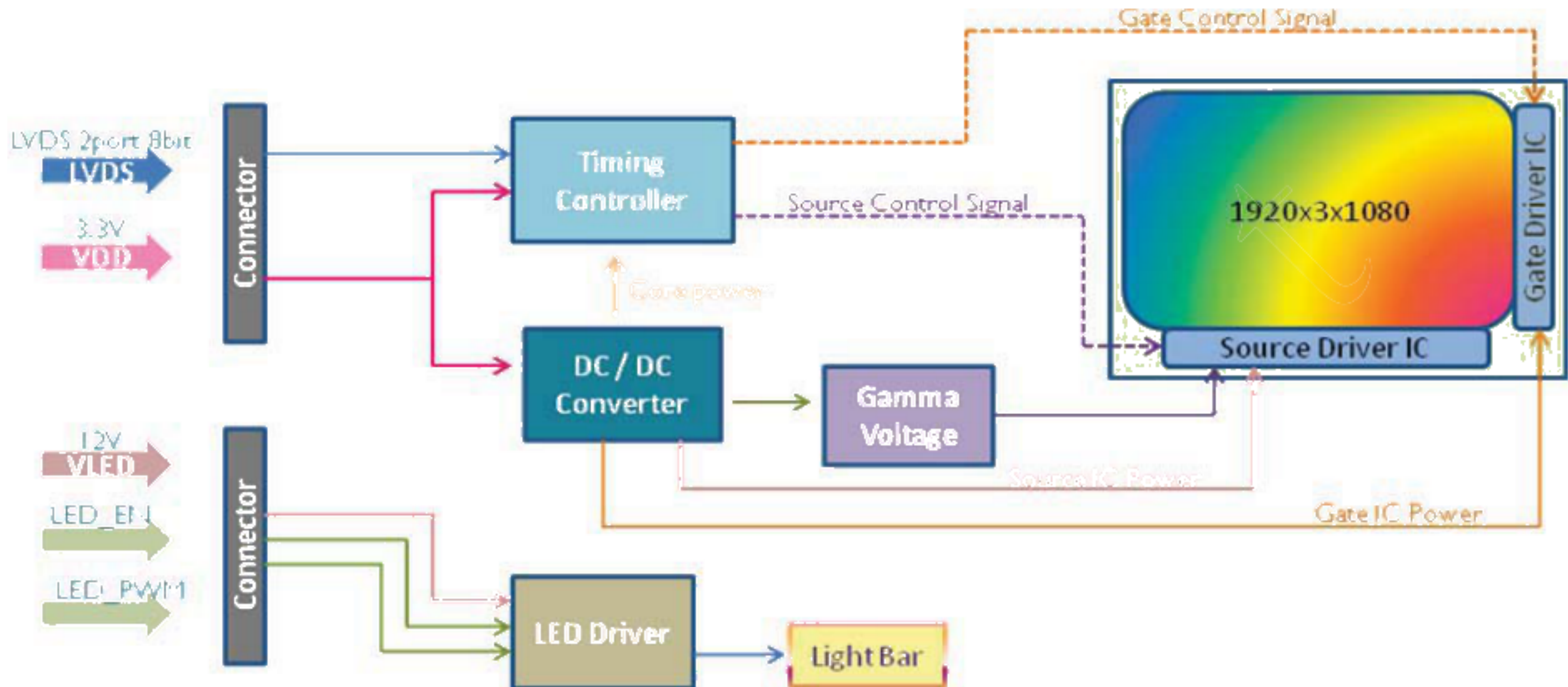

4. Absolute Maximum Ratings

An absolute maximum rating of the module is as following:

4.1 Absolute Ratings of TFT LCD Module

Item	Symbol	Min	Max	Unit	Conditions
Logic/LCD Drive Voltage	VDD	-0.3	+4.0	[Volt]	Note 1,2
BL Input Voltage	VLED	-0.3	+34.0	[Volt]	Note 1,2
Signal Voltage	RinI-/+ , ClkIN-/+	-0.3	VDD	[Volt]	Note 1, I=0,1,2,3
Signal Voltage	LED_EN , LED_PWM	-0.3	+5.5	[Volt]	Note 1,2



Product Specification

AU OPTRONICS CORPORATION

4.2 Absolute Ratings of Environment

Item	Symbol	Min	Max	Unit	Conditions
Operating Temp.	TOP	-20	+70	[°C]	Note 4
Operation Humidity	HOP	8	90	[%RH]	Note 4
Storage Temperature	TST	-20	+70	[°C]	Note 4
Storage Humidity	HST	5	90	[%RH]	Note 4

Note 1: At Ta (25°C)

Note 2: Permanent damage to the device may occur if exceed maximum values

Note 3: LED specification refer to section 5.2

Note 4: For quality performance, please refer to AUO IIS (Incoming Inspection Standard)

5. Electrical Characteristics

5.1 TFT LCD Module

5.1.1 Power Specification

Input power specifications are as follows;

The power specification are measured under 25°C and frame frequency under 60Hz

Symble	Parameter	Min	Typ	Max	Units	Note
VDD	Logic/LCD Drive Voltage	3.0	3.3	3.6	[Volt]	
PDD	VDD Power	-	1.1	1.2	[Watt]	Note 1
IDD	IDD Current	-	333.2	363.6	[mA]	Note 1
IRush	Inrush Current	-	-	1.5	[A]	Note 2
VDDrp	Allowable Logic/LCD Drive Ripple Voltage	-	-	200	[mV] p-p	

Note 1: Maximum Measurement Condition : White Pattern at 3.3V driving voltage ($P_{max}=V_{3.3V} \times I_{white}$)

Note 2: Measure Condition

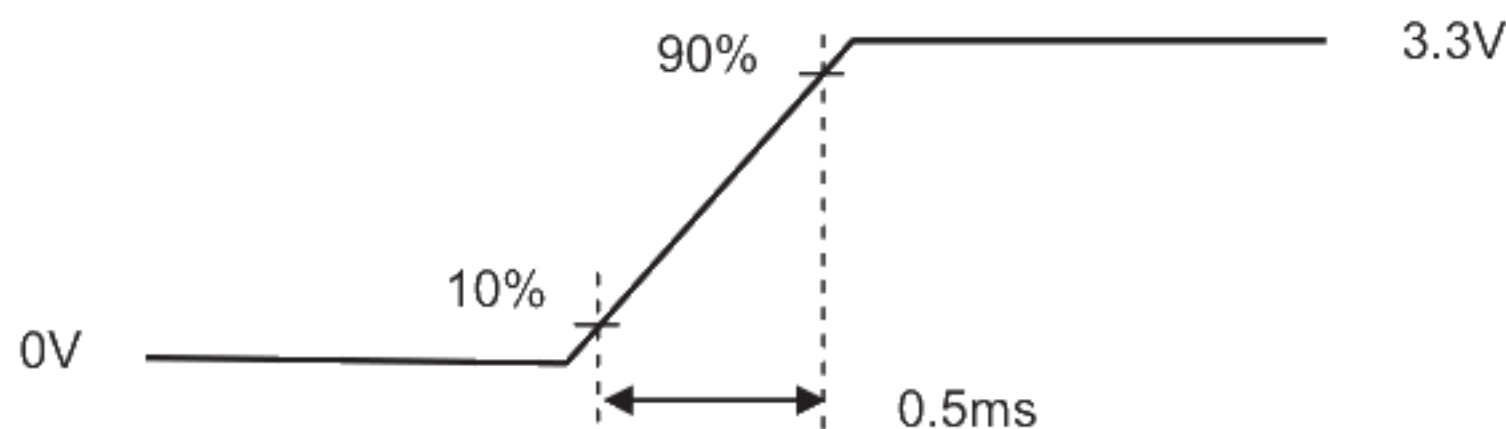
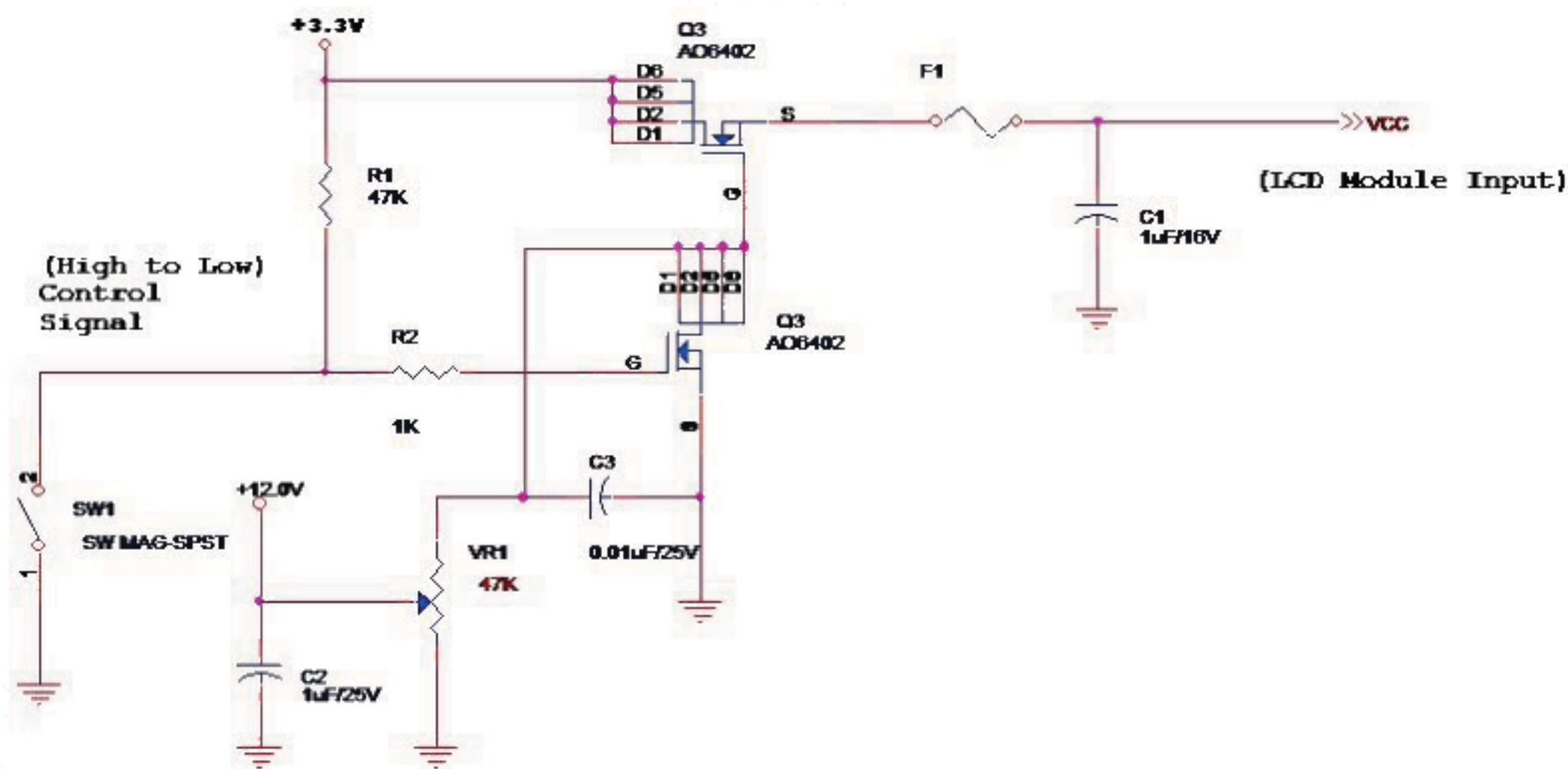

Vin rising time

5.1.2 Signal Electrical Characteristics

Input signals shall be low or High-impedance state when VDD is off.

Signal electrical characteristics are as follows;

Symbol	Parameter	Min	Typ	Max	Units	Condition
V_{TH}	Differential Input High Threshold	-	-	+100	[mV]	$V_{CM} = 1.2V$ Note 1
V_{TL}	Differential Input Low Threshold	-100	-	-	[mV]	$V_{CM} = 1.2V$ Note 1
$ V_{ID} $	Input Differential Voltage	100	400	600	[mV]	Note 1
V_{CM}	Differential Input Common Mode Voltage	+1.125	-	+1.375	[Volt]	$V_{TH}-V_{TL} = 200mV$ (max) Note 1

Note 1: LVDS Signal Waveform

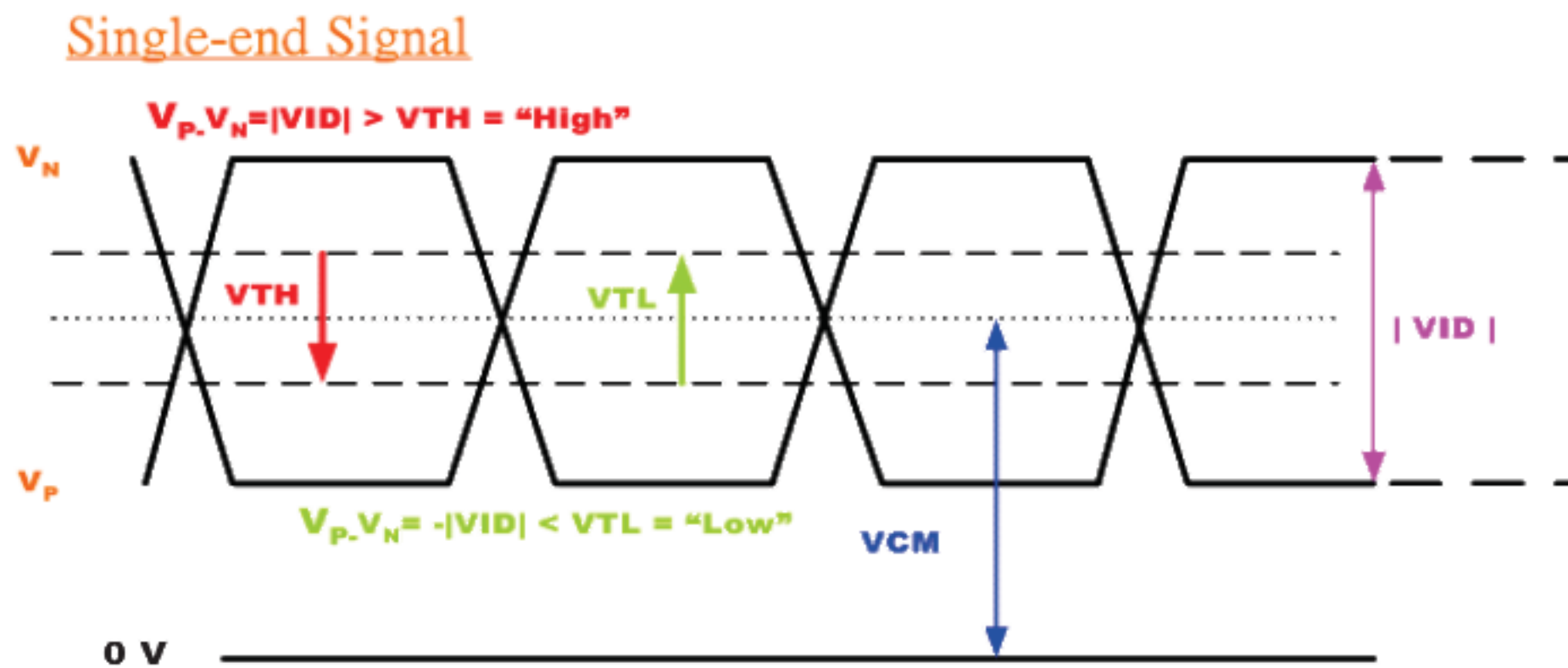

Differential Signal

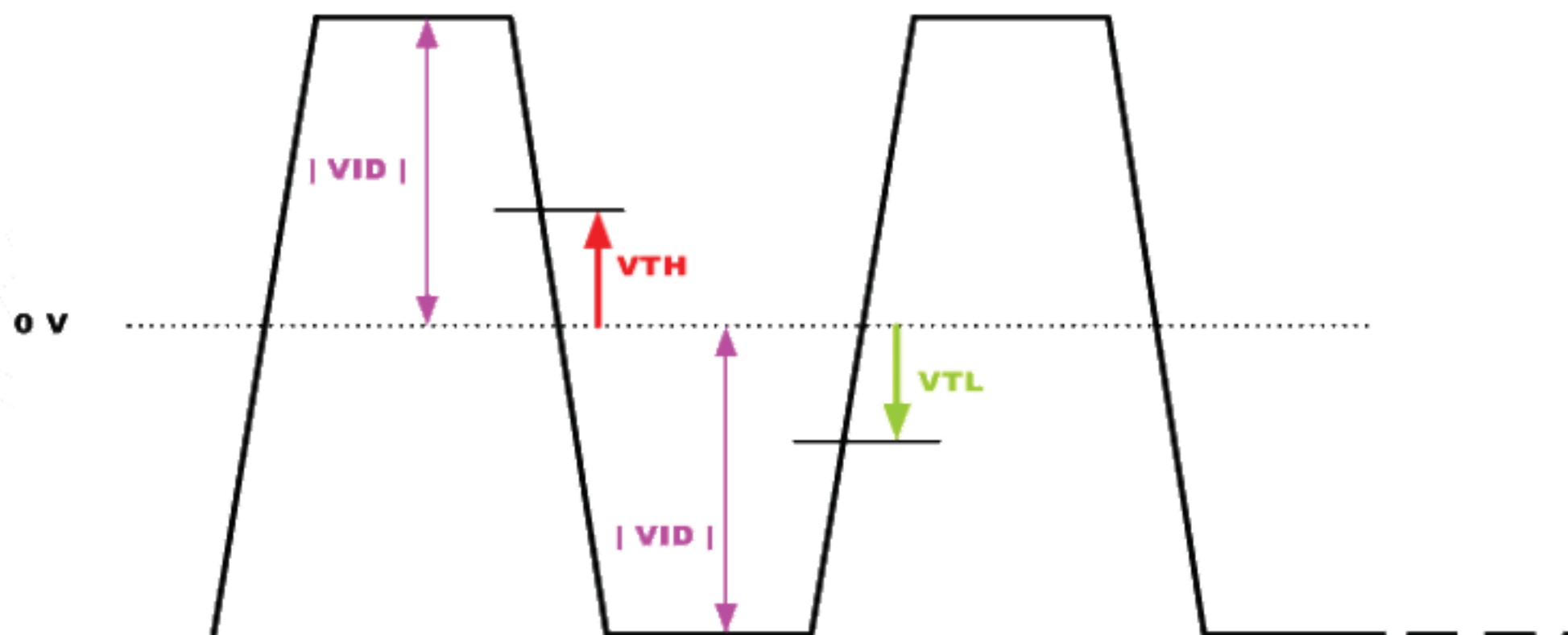

5.2 Backlight Unit

5.2.1 LED characteristics

Parameter	Symbol	Min	Typ	Max	Units	Condition
Backlight Power Consumption	PLED	-	-	15W	[Watt]	(Ta=25°C), Note 1
LED Life-Time	N/A	-	50,000	-	Hour	(Ta=25°C), Note 2

Note 1: Calculator value for reference $P_{LED} = V_F$ (Normal Distribution) * I_F (Normal Distribution) / Efficiency

Note 2: The LED life-time define as the estimated time to 50% degradation of initial luminous.

5.2.2 Backlight input signal characteristics

Parameter	Symbol	Min	Typ	Max	Units	Remark
LED Power Supply	VLED	10.8	12.0	13.2	[Volt]	Define as Connector Interface (Ta=25°C)
LED Input current	ILED	-	-	1.25- (Note 1)	[A]	
LED Enable Input High Level	LED_EN	2	-	5	[Volt]	
LED Enable Input Low Level		-	-	0.5	[Volt]	
PWM Logic Input High Level	LED_PWM	2	-	5	[Volt]	
PWM Logic Input Low Level		-	-	0.5	[Volt]	
PWM Input Frequency	FPWM	500	-	10K	Hz	
PWM Duty Ratio	Duty	5	-	100	%	
LED Inrush Current	ILED _{Rush}	-	-	2	[A]	

Note 1: Maximum LED Input Current Measurement Condition: VLED at 12V driving voltage

6.2 The Input Data Format

Interface	Type	Data
LVDS	JEIDA	8 bit

JEIDA / NS Mapping Format (Using JEIDA)

RXIN1D0 N/P RXIN2D0 N/P	J:RA6=G2 N:RA6=G0	J:RA5=R7 N:RA5=R5	J:RA4=R6 N:RA4=R4	J:RA3=R5 N:RA3=R3	J:RA2=R4 N:RA2=R2	J:RA1=R3 N:RA1=R1	J:RA0=R2 N:RA0=R0
RXIN1D1 N/P RXIN2D1 N/P	J:RB6=B3 N:RB6=B1	J:RB5=B2 N:RB5=B0	J:RB4=G7 N:RB4=G5	J:RB3=G6 N:RB3=G4	J:RB2=G5 N:RB2=G3	J:RB1=G4 N:RB1=G2	J:RB0=G3 N:RB0=G1
RXIN1D2 N/P RXIN2D2 N/P	J:RC6=DE N:RC6=DE	J:RC5=VS N:RC5=VS	J:RC4=HS N:RC4=HS	J:RC3=B7 N:RC3=B5	J:RC2=B6 N:RC2=B4	J:RC1=B5 N:RC1=B3	J:RC0=B4 N:RC0=B2
RXIN1D3 N/P RXIN2D3 N/P	J:RD6=X N:RD6=X	J:RD5=B1 N:RD5=B7	J:RD4=B0 N:RD4=B6	J:RD3=G1 N:RD3=G7	J:RD2=G0 N:RD2=G6	J:RD1=R1 N:RD1=R7	J:RD0=R0 N:RD0=R6

6.3 Signal Description (CN1)

The module uses one LVDS receiver. LVDS is a differential signal technology for LCD interface and high speed data transfer device. The first LVDS port(RxOxxx) transmits odd pixels while the second LVDS port(RxExxx) transmits even pixels.

Pin	Signal	Description
1	RxOIN0-	Negative LVDS differential data input (Odd data)
2	RxOIN0+	Positive LVDS differential data input (Odd data)
3	RxOIN1-	Negative LVDS differential data input (Odd data)
4	RxOIN1+	Positive LVDS differential data input (Odd data)
5	RxOIN2-	Negative LVDS differential data input (Odd data, DSPTMG)
6	RxOIN2+	Positive LVDS differential data input (Odd data, DSPTMG)
7	GND	Power Ground
8	RxOCLKIN-	Negative LVDS differential clock input (Odd clock)
9	RxOCLKIN+	Positive LVDS differential clock input (Odd clock)
10	RxOIN3-	Negative LVDS differential data input (Odd data)
11	RxOIN3+	Positive LVDS differential data input (Odd data)
12	RxEIN0-	Negative LVDS differential data input (Even data)
13	RxEIN0+	Positive LVDS differential data input (Even data)
14	GND	Power Ground
15	RxEIN1-	Positive LVDS differential data input (Even data)
16	RxEIN1+	Negative LVDS differential data input (Even data)
17	GND	Power Ground
18	RxEIN2-	Negative LVDS differential data input (Even data)
19	RxEIN2+	Positive LVDS differential data input (Even data)
20	RxECLKIN-	Negative LVDS differential clock input (Even clock)
21	RxECLKIN+	Positive LVDS differential clock input (Even clock)
22	RxEIN3-	Negative LVDS differential data input (Even data)
23	RxEIN3+	Positive LVDS differential data input (Even data)
24	GND	Power Ground
25	AGBSEN	For AUO internal use (NC)
26	VDD	Power +3.3V
27	VDD	Power +3.3V
28	SCL	For AUO internal use (NC)
29	SDA	For AUO internal use (NC)
30	GND	Power Ground

6.4 Interface Timing (LVDS)

6.4.1 Timing Characteristics

Basically, interface timings should match the 1920x1080/ 60Hz manufacturing guide line timing.

Parameter	Symbol	Min.	Typ.	Max.	Unit	
Frame Rate	-	60	60	60	Hz	
Clock frequency	$1/T_{Clock}$	69.22	70.57	73.9	MHz	
Horizontal Section	Period	T_H	1045	1054	1090	T_{clock}
	Active	T_{HD}	960			
	Blanking	T_{HB}	85	94	130	
Vertical Section	Period	T_V	1104	1116	1130	T_{line}
	Active	T_{VD}	1080			
	Blanking	T_{VB}	24	36	50	

Note1 : The above is as optimized setting

Note2 : Horizontal related parameters must be constant without variation(H_Sync_Width, H_Front_Porch and H_Back_Porch must be constant on each scanline).

Note3 : On vertical blank area, H_Sync_Width and H_Total must be same as on the V_Active area.

Note4 : Vertical related parameters must be constant without variation.(V_Sync_Width, V_Front_Porch and V_Back_Porch must be constant on each video field).

Note5 : The DE timings also must be constant without variation(H/V timing requirements are as same as previous. Blank timing must also be constant).

6.4.2 Timing Diagram

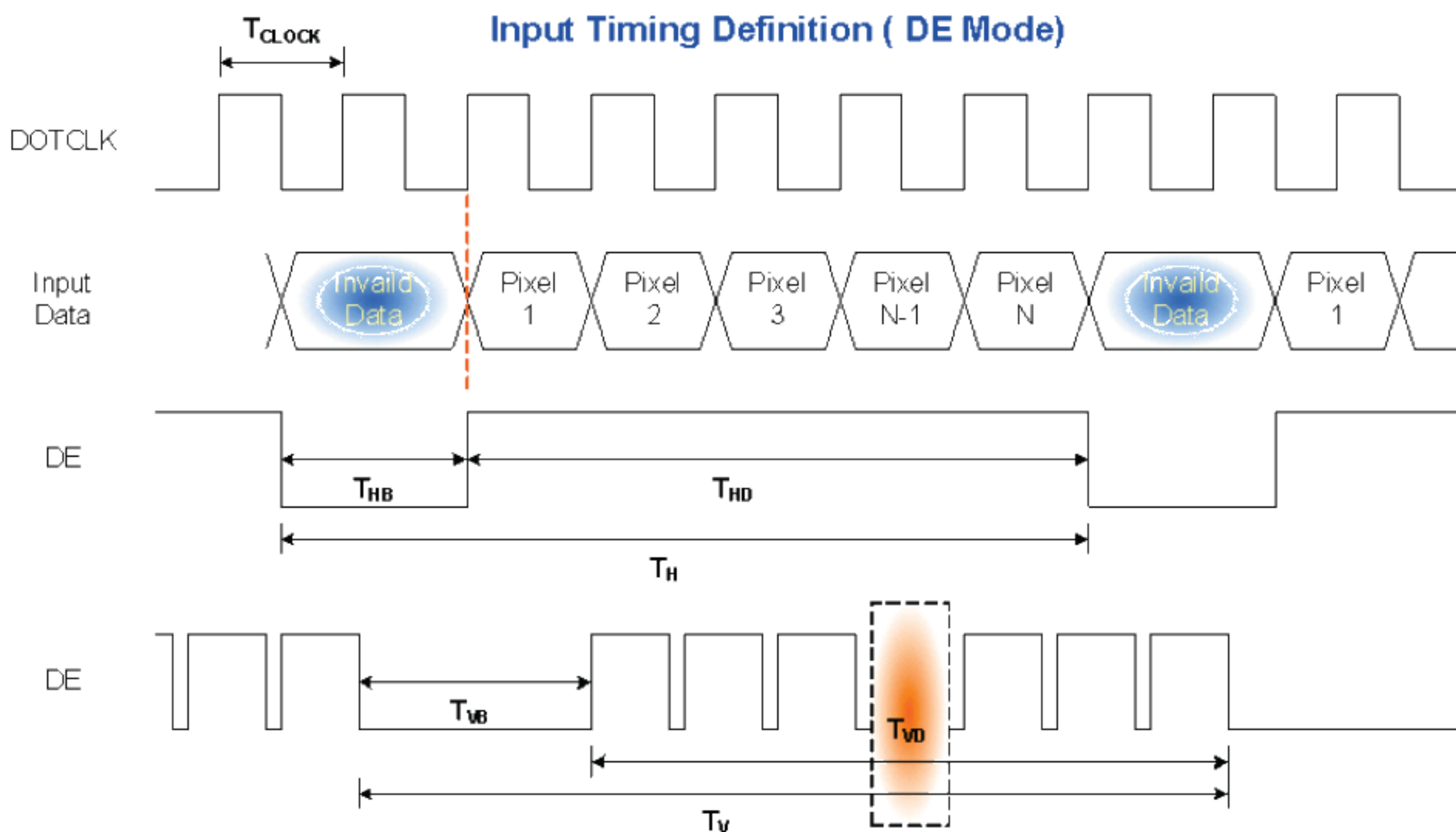

6.5 Power ON/OFF Sequence

VDD power and LED on/off sequence is as below. Interface signals are also shown in the chart. Signals from any system shall be Hi-Z state or low level when VDD is off.

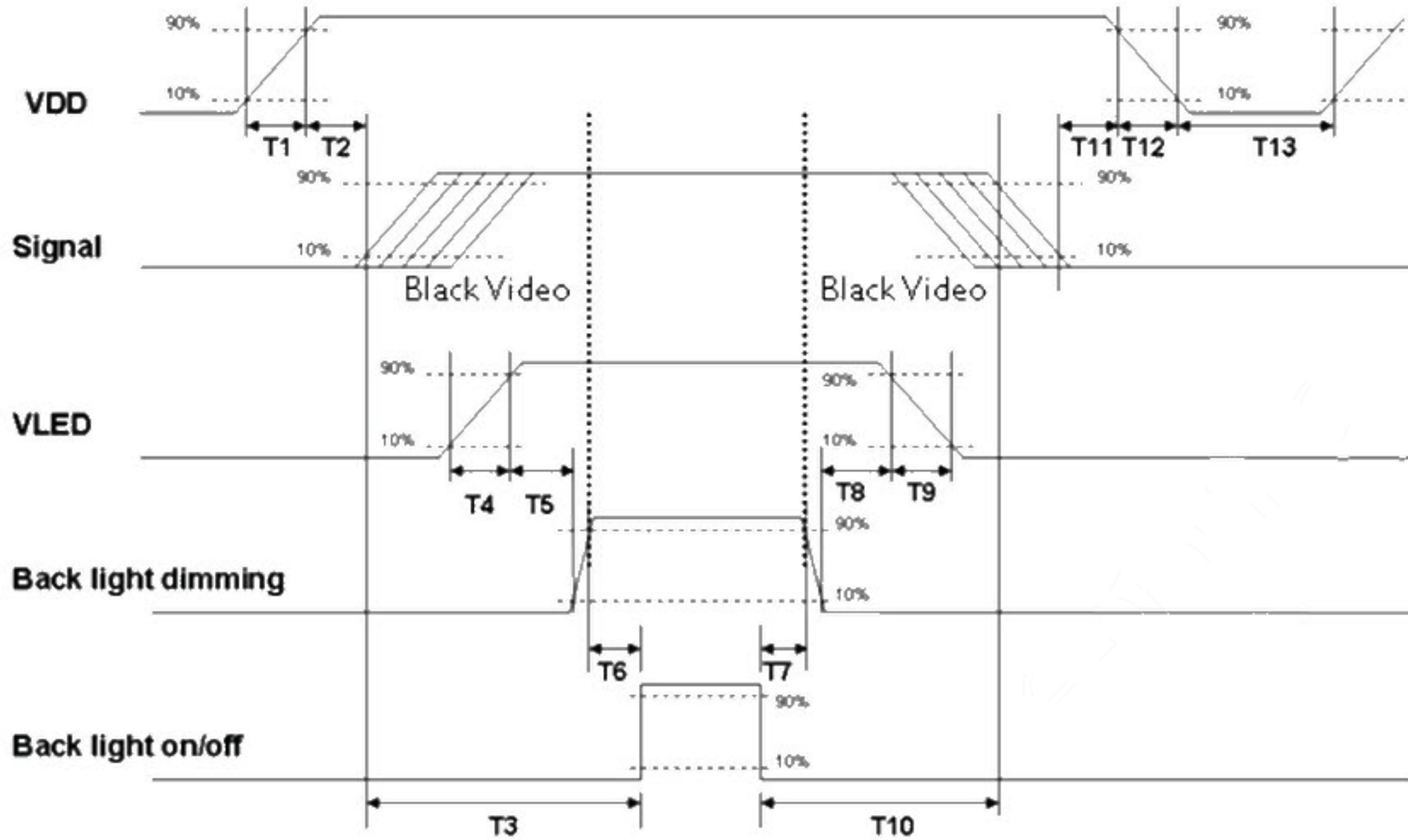

Power ON/OFF sequence timing

Parameter	Value			Units
	Min.	Typ.	Max.	
T1	0.5	-	9	[ms]
T2	10	-	50	[ms]
T3	400	-	-	[ms]
T4	0.5	-	10	[ms]
T5	10	-	-	[ms]
T6	10	-	-	[ms]
T7	10	-	-	[ms]
T8	10	-	-	[ms]
T9	0.5	-	10	[ms]
T10	50	-	-	[ms]
T11	10	-	-	[ms]
T12	-	-	10	[ms]
T13	1000	-	-	[ms]

The above on/off sequence should be applied to avoid abnormal function in the display. Please make sure to turn off the power when you plug the cable into the input connector or pull the cable out of the connector.

7. Connector & Pin Assignment

Physical interface is described as for the connector on module. These connectors are capable of accommodating the following signals and will be following components.

7.1 TFT LCD Module

7.1.1 Connector(CN1)

Connector Name / Designation	Interface Connector / Interface card
Manufacturer	Hirose
Type Part Number	DF19K-30P-1H (54)
Mating Housing Part Number	DF19G-30S-1C(05) DF19A-2830SCFA(41)

7.1.2 Pin Assignment(CN1)

Pin#	Signal Name	Pin#	Signal Name
1	RxOIN0-	2	RxOIN0+
3	RxOIN1-	4	RxOIN1+
5	RxOIN2-	6	RxOIN2+
7	GND	8	RxOCLKIN-
9	RxOCLKN+	10	RxOIN3-
11	RxOIN3+	12	RxEIN0-
13	RxEIN0+	14	GND
15	RxEIN1-	16	RxEIN1+
17	GND	18	RxEIN2-
19	RxEIN2+	20	RxECLKIN-
21	RxECLKIN+	22	RxEIN3-
23	RxEIN3+	24	GND
25	AGBSEN(NC)	26	VDD
27	VDD	28	SCL (NC)
29	SDA (NC)	30	GND

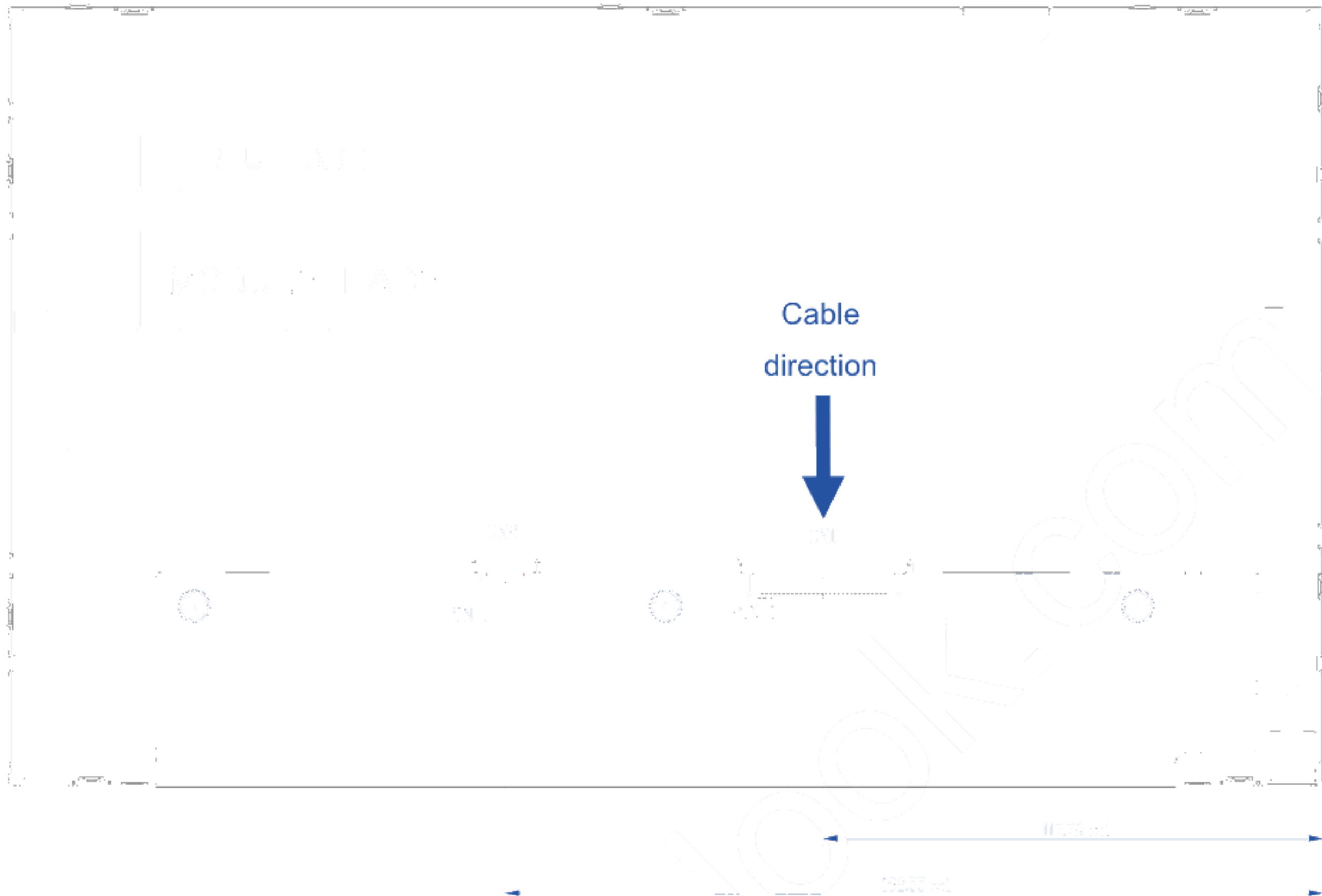

7.2 Backlight Unit

Physical interface is described as for the connector on module. These connectors are capable of accommodating the following signals and will be following components.

7.2.1 Connector (CN2)

Connector Name / Designation	LED Connector
Manufacturer	Hirose
Type Part Number	DF19G-8P-1H(54)
Mating Housing Part Number	DF19G-8S-1C(05) DF19A-2830SCFA(41)

7.2.2 LED Driver Connector Pin Assignment (CN2)

Pin#	Symbol	Signal Name
1	LED_EN	LED enable pin
2	LED_PWM	System PWM Single Input
3	NC	No connect
4	VLED	+12V
5	VLED	+12V
6	NC	No connect
7	GND	Ground
8	GND	Ground

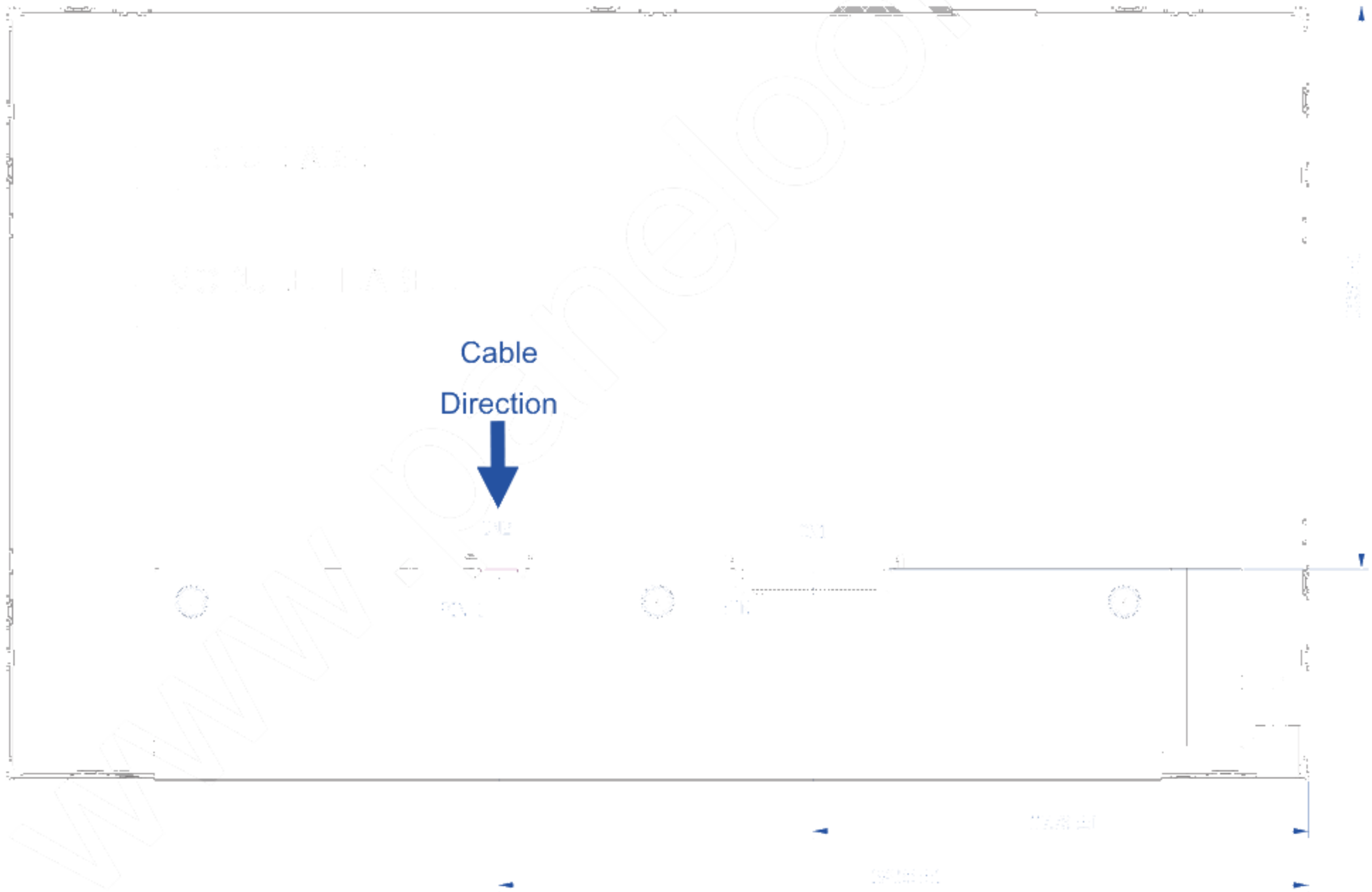

8. Panel Reliability Test

Items	Required Condition	Note
Temperature Humidity Bias	Ta= 40°C, 90%RH, 300h	Note 1,2
High Temperature Operation	Ta= 70°C , Dry, 300h	
Low Temperature Operation	Ta=-20°C, 300h	
High Temperature Storage	Ta= 70°C, Dry, 300h	
Low Temperature Storage	Ta= -20°C, 300h	
Thermal Shock Test	Ta=-20°C to 60°C, Duration at 30 min, 50 cycles	Note 1,2
Vibration test(non-operation)	1.5G, (10~200Hz~10, random), 30 mins/axis (X, Y, Z)	
Shock Test(non-operation)	50G,20ms,Half-sine wave,(±X, ±Y, ±Z)	Note 1
ESD	Contact Discharge: ±8 KV, 150pF(330 Ω) 1sec, 8Points, 25times/point Air Discharge: ±15 KV, 150pF(330 Ω) 1sec, 8Points, 25times/point	

Note 1: According to EN 61000-4-2 , ESD class B: Some performance degradation allowed.
Self-recoverable. No data lost, No hardware failures.

Note 2:

- Water condensation is not allowed for each test items.
- Each test is done by new TFT-LCD module. Don't use the same TFT-LCD module repeatedly for reliability test.
- The reliability test is performed only to examine the TFT-LCD module capability.
- To inspect TFT-LCD module after reliability test, please store it at room temperature and room humidity for 24 hours at least in advance.
- No function failure occurs. Mura shall be ignored after high temperature reliability test

9. Label and Package

9.1 Shipping Label Format

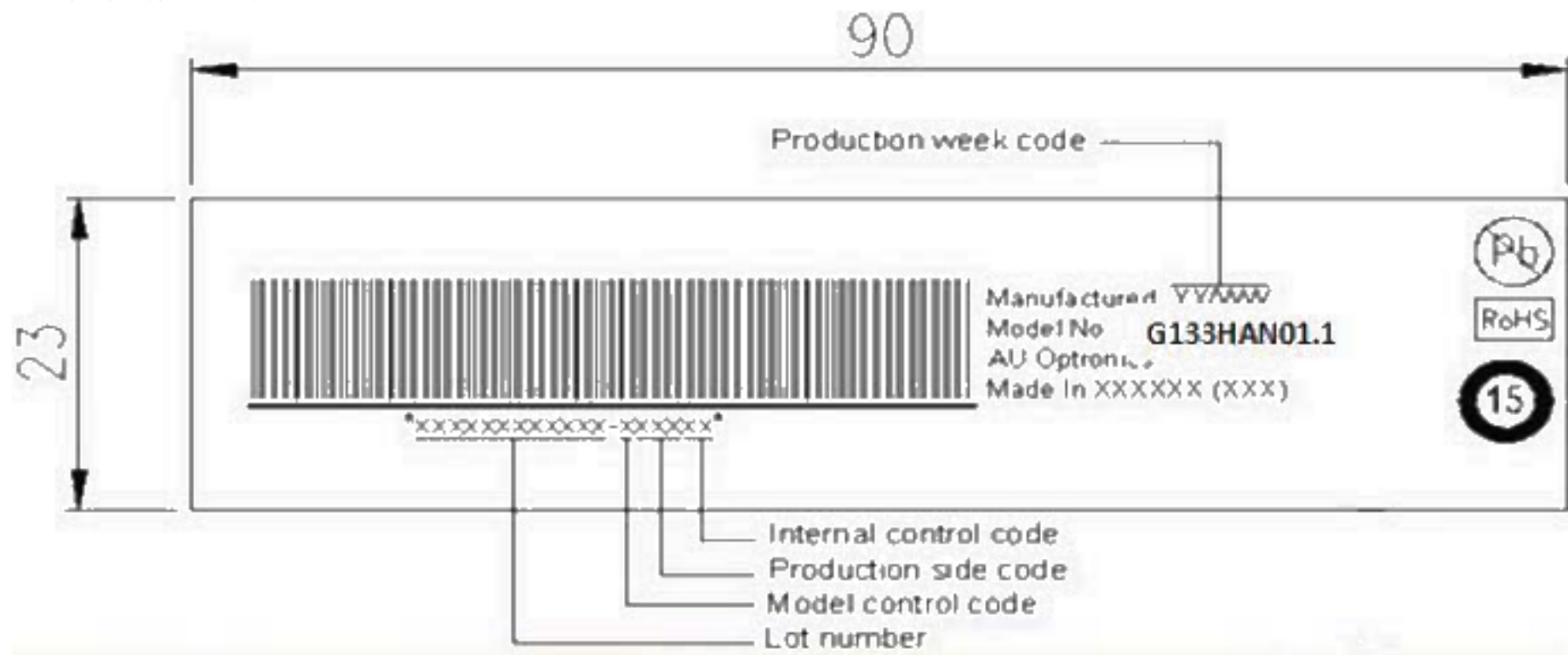

9.2 Carton Package

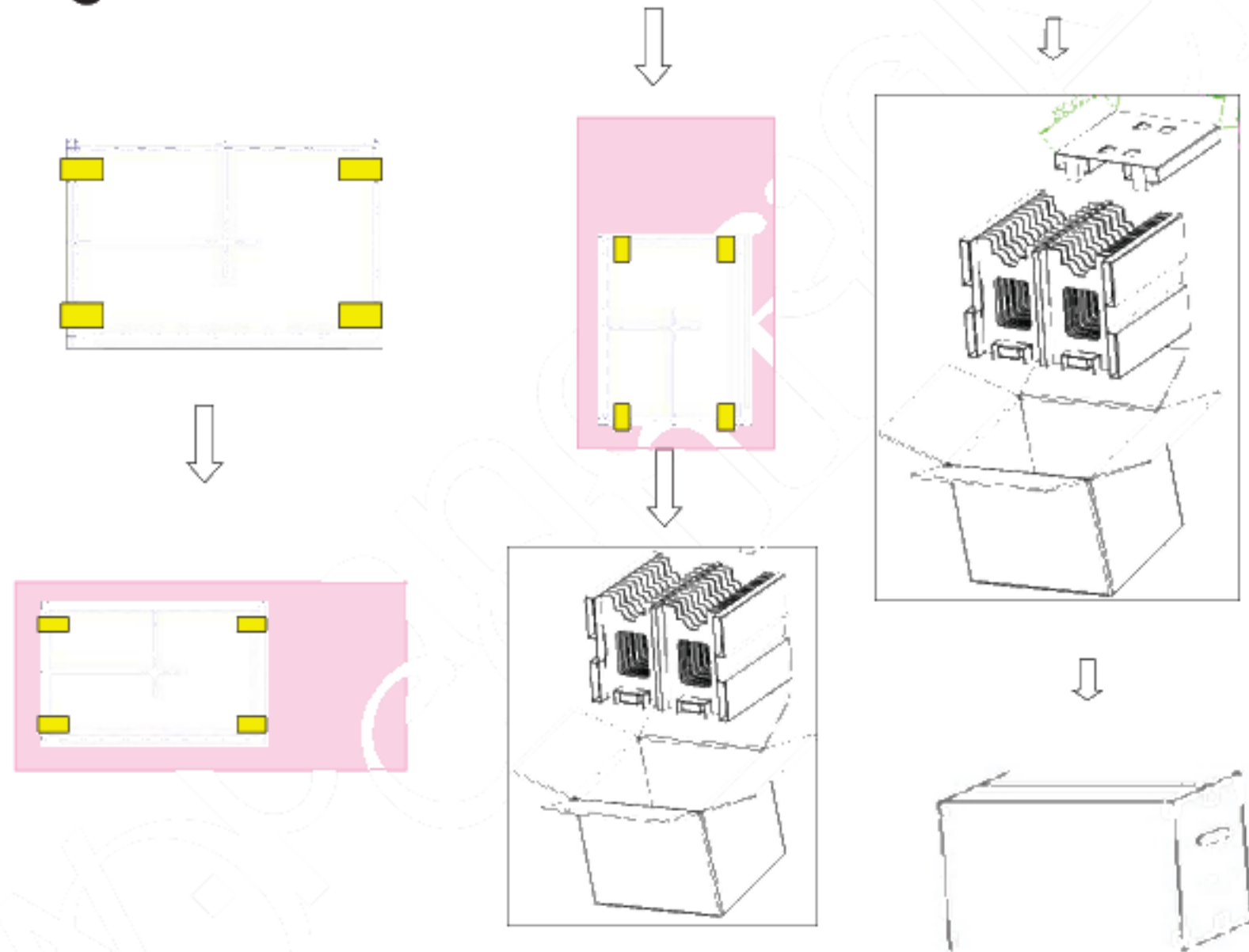

Max capacity : 20 TFT-LCD module per carton

Max weight: 10.5 kg per carton

Outside dimension of carton: 480mm(L)*275mm(W)*450mm(H)

Pallet size : 1150 mm * 910 mm * 132mm

Box stacked

Module by air : (2 *3) *3 layers , one pallet put 18 boxes , total 360pcs module

Module by sea : (2 *3) *3 layers+ one pallet (2 *3) *1 layer , total 480pcs module

Module by sea_HQ : (2 *3) *3 layers+ one pallet (2 *3) *1 layer , total 480pcs module

